

MULTIMETER

3490A

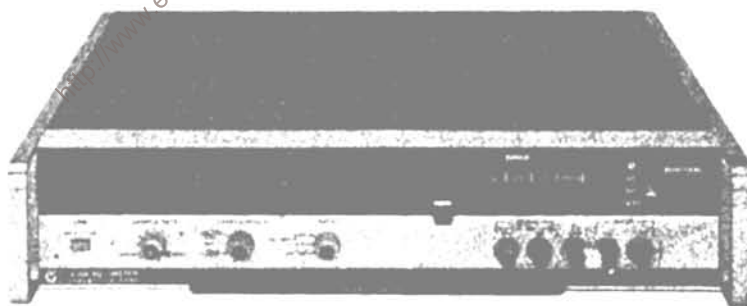

HEWLETT  PACKARD



OPERATING AND SERVICE MANUAL

Manual Part No. 03490-90016
Microfiche Part No. 03490-90066

MODEL 3490A MULTIMETER

The main body of this manual applies to

Serial Prefix 1529A

Any changes made in instruments manufactured after this printing will be found in a "Manual Changes" supplement supplied with this manual. Be sure to examine this supplement, if one exists for this manual, for any changes which apply to your instrument and record these changes in the manual. Backdating information for instruments manufactured before this printing will be found in Section VIII.

Copyright Hewlett-Packard Company 1972
P.O. Box 301, Loveland, Colorado 80537 U.S.A.

Printed: June 1976

CERTIFICATION

Hewlett-Packard Company certifies that this instrument met its published specifications at the time of shipment from the factory. Hewlett-Packard Company further certifies that its calibration measurements are traceable to the United States National Bureau of Standards, to the extent allowed by the Bureau's calibration facility, and to the calibration facilities of other International Standards Organization members.

WARRANTY AND ASSISTANCE

This Hewlett-Packard product is warranted against defects in materials and workmanship for a period of one year from the date of shipment, except that in the case of certain components, if any, listed in Section I of this operating manual, the warranty shall be for the specified period. Hewlett-Packard will, at its option, repair or replace products which prove to be defective during the warranty period provided they are returned to Hewlett-Packard, and provided the proper preventive maintenance procedures as listed in this manual are followed. Repairs necessitated by misuse of the product are not covered by this warranty. **NO OTHER WARRANTIES ARE EXPRESSED OR IMPLIED, INCLUDING BUT NOT LIMITED TO THE IMPLIED WARRANTIES OF MERCHANTABILITY AND FITNESS FOR A PARTICULAR PURPOSE. HEWLETT-PACKARD IS NOT LIABLE FOR CONSEQUENTIAL DAMAGES.**

If this product is sold as part of a Hewlett-Packard integrated instrument system, the above warranty shall not be applicable, and this product shall be covered only by the system warranty.

Service contracts or customer assistance agreements are available for Hewlett-Packard products.

For any assistance, contact your nearest Hewlett-Packard Sales and Service Office. Addresses are provided at the back of this manual.

TABLE OF CONTENTS

Section	Page	Section III (cont'd)	Page
I. GENERAL INFORMATION	1-1	3-36. Manual Trigger	3-3
1-1. Introduction	1-1	3-38. Self-Test Operation	3-3
1-5. Specifications	1-1	3-40. DC Voltage Measurements	3-3
1-8. Options	1-1	3-42. DC Sample Rate and Response Time	3-4
1-10. Accessories Supplied	1-1	3-44. Input Resistance	3-4
1-12. Accessories Available	1-1	3-46. AC Voltage Measurements	3-4
1-15. Instrument and Manual Identification	1-2	3-48. AC Sample Rate and Response Time	3-4
Section	Page	3-50. Frequency Range	3-4
II. INSTALLATION AND INTERFACE	2-1	3-52. Input Impedance	3-4
2-1. Introduction	2-1	3-54. Harmonic Distortion	3-4
2-3. Initial Inspection	2-1	3-56. Resistance Measurements	3-4
2-5. Power Requirements	2-1	3-58. Input Connections	3-5
2-8. Power Cords and Receptacles	2-1	3-60. Ohms Signal Voltage and Current	3-5
2-10. Grounding Requirements	2-1	3-62. Ohmmeter Sample Rate and Response Time	3-5
2-14. Environmental Requirements	2-1	3-64. External Trigger (Option 020)	3-5
2-16. Installation	2-2	3-66. Data Output (Option 021)	3-5
2-17. Bench Use	2-2	3-68. Output Signals and Levels	3-5
2-19. Rack Mounting	2-2	3-71. Input Signals and Levels	3-6
2-21. Installation of Options	2-2	3-73. Data Output Isolation	3-6
2-23. Isolated Data Output Option 021 (-hp-11121A)	2-2	3-75. Remote Control (Option 022)	3-6
2-25. Isolated Remote Option 022 (-hp-11122A)	2-2	3-77. Input Signal Requirements	3-6
2-27. Option 050 and Option 060	2-3	3-79. Output Signals	3-6
2-29. Interface Connections	2-3	3-81. Remote Programming Procedure	3-6
2-30. Data Output Option 021	2-2	3-83. Remote Control of Test Function	3-6
2-32. Remote Control Option 022	2-3	3-85. Remote Control Isolation	3-6
2-34. Rear Input	2-6	3-87. Hewlett-Packard Interface Bus I/O (Option 030)	3-7
2-36. Hewlett-Packard Interface Bus Connections	2-6	3-90. HP-IB Signals	3-7
2-38. Interface Cable Length	2-6	3-101. Talk Only (No Controller)	3-8
2-40. Trigger Connections, HP-IB Option 030	2-8	3-103. HP-IB Control of 3490A	3-8
2-42. Sample/Hold Connections, Option 040/045	2-8	3-131. HP-IB Operating Example	3-13
2-46. Repackaging for Shipment	2-9	3-136. Invalid Programming Sequences	3-14
Section	Page	3-139. Control By Marked Card Programmer	3-14
III. OPERATING INSTRUCTIONS	3-1	3-142. Sample/Hold Measurements (Option 040 or 045)	3-15
3-1. Introduction	3-1	3-143. Definition of Sample/Hold Terms	3-15
3-3. Instrument Capabilities	3-1	3-155. Special S/H Operating Considerations	3-16
3-4. Standard Instrument	3-1	3-159. Guard Connection in Sample/Hold Measurements	3-16
3-6. Output and Remote Control Options	3-1	3-161. Input Signal Limitations	3-16
3-9. Sample/Hold Option 040 or 045	3-1	3-163. Sample/Hold Trigger Signal Requirements	3-16
3-11. Ratio Option 080	3-1	3-168. Initiating a Sample/Hold Measurement	3-17
3-13. Front and Rear Panel Description	3-1	3-176. Using the Track/Hold Mode	3-19
3-15. Maximum Input Voltages	3-1	3-182. Using the Acquire/Hold Mode	3-20
3-17. General Operating Instructions	3-2	3-185. Using 50 Hz or 60 Hz Power Source (Options 050 or 060)	3-21
3-18. Turn-On and Warm-Up	3-2	3-187. Ratio Measurements (Option 080)	3-21
3-20. Guarding	3-2	3-189. External REference Voltages	3-21
3-24. Floating Measurements	3-2	3-191. Input Connections	3-21
3-26. Overrange Measurements	3-3	3-193. Ratio Display	3-22
3-28. Overload Indication	3-3	3-195. Ratio Measurement Procedure	3-22
3-30. Range Indication	3-3		
3-32. Function Indication	3-3		
3-34. Autoranging	3-3		

TABLE OF CONTENTS (Cont'd)

Section	Page	Section IV (cont'd)	Page
IV. THEORY OF OPERATION	4-1	4-130. Power Supplies	4-15
4-1. Introduction	4-1	4-132. Self-Test Function	4-16
4-3. General Theory of Operation	4-1	4-134. Logic Test, No. 1	4-16
4-5. Signal Conditioning Circuits	4-1	4-137. 10 V Range Zero, Test No. 2	4-17
4-7. Reference Voltages	4-1	4-139. Turnover Error, Test No. 3	4-17
4-9. DC Amplifier	4-1	4-141. + Reference Check, Test No. 4	4-17
4-11. Analog-to-Digital Converter	4-1	4-143. 0.1 V Range Zero, Test No. 5	4-17
4-13. Logic	4-1	4-145. x .01 Atten., x 100 Gain, Test No. 6	4-17
4-15. Display	4-2	4-147. Ohms Reference, Test No. 7	4-17
4-17. Range and Function Control	4-2	4-149. BCD Remote Expand Option 020 (Figure 7-31)	4-17
4-19. DC Analog Circuits	4-2	4-150. Outguard Power Supply	4-17
4-21. Input Attenuator	4-2	4-152. Isolated Trigger and Hold	4-18
4-23. DC Amplifier	4-3	4-154. Sample/Hold Trigger Circuits	4-18
4-25. DC Amplifier Gain	4-3	4-158. Data Output Option 021	4-18
4-27. Switching Circuits	4-3	4-160. Data Multiplexers	4-18
4-29. Bootstrap Circuit	4-3	4-162. Data Output Sequential Logic	4-18
4-31. Reference Voltages	4-3	4-164. Data Clock	4-18
4-33. Overload Protection	4-3	4-166. Isolation Assembly	4-18
4-35. Leakage Control	4-3	4-168. Shift Registers	4-18
4-37. DC Amplifier Auto Zero	4-3	4-170. Data Flag	4-19
4-39. Integrator Circuits	4-5	4-172. Printer Hold	4-19
4-40. Dual-Slope Integration	4-5	4-174. Remote Control Option 022	4-19
4-42. Integrating Amplifier	4-5	4-176. Circuit Isolation	4-19
4-44. x 20 Amplifier	4-6	4-178. Remote Enable	4-19
4-46. Zero Detect Amplifier	4-6	4-180. Outguard Multiplexer	4-19
4-48. Electronic Switch	4-6	4-182. Remote Sequential Logic	4-19
4-50. Integrator Auto Zero	4-6	4-184. Program Flag	4-19
4-52. AC Converter	4-6	4-186. Data Clock	4-20
4-54. AC Attenuators	4-6	4-188. Shift Registers	4-20
4-56. Converter Amplifier	4-6	4-190. Local/Remote Multiplexers	4-20
4-58. Rectifier and Filter	4-7	4-192. Local/Remote Flip-Flop	4-20
4-60. Ohms Converter	4-7	4-194. Data Flag	4-20
4-62. Current Source	4-7	4-196. Hewlett-Packard Interface Bus I/O (Option 030)	4-20
4-64. Ohmmeter Power Supply	4-7	4-198. HP-IB System	4-20
4-66. Ohmmeter Reference	4-8	4-201. Basic Theory of HP-IB I/O Circuits	4-21
4-68. Input Protection	4-8	4-204. HP-IB System Operation	4-21
4-70. Display Assembly (Figure 7-27)	4-8	4-212. Sample/Hold Option 040 or 045	4-22
4-71. Display Units	4-8	4-214. Track/Hold Mode	4-22
4-73. Scan Generator	4-8	4-216. Acquire/Hold Mode	4-22
4-75. BCD to-Seven-Segment Decoder	4-8	4-218. Sample/Hold Measurement Sequence	4-22
4-77. Polarity Display	4-8	4-221. Sample/Hold Analog Circuits	4-23
4-79. Decimals and Annunciators	4-8	4-228. Sample/Hold Logic Circuits	4-25
4-81. Logic Circuits	4-8		
4-82. Clock	4-8		
4-84. Data Counter	4-9		
4-86. Buffers	4-9		
4-88. Timing Counter	4-9		
4-90. Algorithmic State Machine	4-11		
4-105. Input Polarity Storage	4-12		
4-107. Transfer and Zero Detect	4-12		
4-113. Overload Storage	4-13		
4-115. DC Switching Logic	4-13		
4-117. Reference Supplies	4-13		
4-118. Voltage Measurements	4-13		
4-122. Ratio Measurements (Option 080)	4-14		
4-128. Front Panel Switching	4-15		
		Section	Page
		V. MAINTENANCE	5-1
		5-1. Introduction	5-1
		5-3. Recommended Test Equipment	5-1
		5-5. Test Record	5-1
		5-7. Performance Tests	5-1
		5-9. DC Voltmeter Accuracy Test	5-1
		5-11. AC Voltmeter Accuracy Tests	5-1
		5-15. Ohmmeter Accuracy Tests	5-2
		5-16. Preferred Method	5-2

TABLE OF CONTENTS (Cont'd)

Section V (cont'd)	Page	Section	Page
5-18. Alternate Method	5-2	VII. TROUBLESHOOTING AND	
5-20. DC Common-Mode Rejection Test	5-2	CIRCUIT DIAGRAMS	7-1
5-22. AC Common-Mode Rejection Test	5-4	7-1. Introduction	7-1
5-24. AC Normal-Mode Rejection Test	5-4	7-3. Preliminary Troubleshooting	7-1
5-26. DC Voltmeter Input		7-5. Troubleshooting Trees	7-1
Resistance Test	5-4	7-7. Access for Servicing	7-1
5-28. AC Voltmeter Input		7-9. Power Supply Checks	7-1
Impedance Test	5-5	7-13. DC Analog Circuits	7-2
5-30. Sample/Hold Performance		7-15. A2 Assembly Exchange	7-2
(Option 040/045)	5-5	7-17. DC Amplifier Checks	7-2
5-32. Sample/Hold DC Measurement		7-22. DC Amplifier Switching Circuits	7-3
Accuracy Test	5-6	7-25. Replacement of QCR301	7-3
5-34. Sample/Hold Response Test	5-6	7-27. A-to-D Conversion Circuit Checks	7-3
5-36. Ratio Performance (Option 080)	5-7	7-31. Integrator Troubleshooting	7-4
5-38. DC/DC Ratio Accuracy Tests	5-7	7-33. AC Converter Troubleshooting	7-4
5-41. AC/DC Ratio Accuracy Test	5-8	7-37. Ohms Converter Troubleshooting	7-4
5-43. External Reference Input		7-40. Display Troubleshooting	7-5
Resistance Test	5-8	7-42. Logic Troubleshooting	
5-45. HP-IB Operation Check (Option 030) ..	5-8	Suggestions	7-5
5-47. General Test Procedure	5-11	7-48. Data Output Troubleshooting	
5-49. Test Procedure Using		(Option 021)	7-5
Model 9820A Calculator	5-11	7-50. Remote Control Troubleshooting	
5-51. Adjustment Procedures	5-14	(Option 022)	7-5
5-53. Power Supply Adjustment	5-14	7-52. HP-IB Troubleshooting	
5-55. DC Zero Adjustments	5-15	(Option 030)	7-5
5-57. Reference Adjustments	5-15	7-53. General Checks	7-5
5-59. DC Amplifier Adjustments	5-15	7-55. Troubleshooting Method	7-5
5-61. AC Converter Adjustments	5-15	7-57. External Trigger Circuit Check	7-6
5-63. 1 V Range Adjustments	5-16	7-59. Sample/Hold Servicing	7-6
5-64. 10 V Range Adjustments	5-16	7-60. Access to Sample/Hold Circuits	7-6
5-65. 100 V Range Adjustments	5-16	7-63. Operating the 3490A with	
5-66. Ohmmeter Adjustments	5-16	Sample/Hold Assemblies Removed ..	7-6
5-69. Sample/Hold Adjustments	5-16	7-65. Sample/Hold Troubleshooting Trees ..	7-6
5-71. Offset Gain Adjustment	5-16	7-67. Ratio Troubleshooting	7-8
5-73. Offset Adjustment	5-17	7-69. External Reference Amplifier	
5-75. Dielectric Absorption Adjustment	5-17	Checks	7-8
5-77. Response Adjustment	5-18	7-71. Amplifier Zero Offset	7-8
5-79. Ratio Reference Adjustments	5-18	7-73. Reference Polarity Logic Checks	7-8
		7-75. Schematic Notes	7-8
		7-77. Logic Gate Symbols	7-9
Section	Page	Section	Page
VI. REPLACEABLE PARTS	6-1	VIII. BACKDATING	8-1
6-1. Introduction	6-1	8-1. Introduction	8-1
6-4. Ordering Information	6-1	8-3. Change Sequence	8-1
6-6. Non-Listed Parts	6-1	8-5. Parts Not Listed	8-1
6-8. Proprietary Parts	6-1		

APPENDICES

- A. Code List of Manufacturers
- B. Sales and Service Offices

LIST OF ILLUSTRATIONS

Figure	Page	Figure	Page
2-1. Line Voltage Selection	2-1	4-23. Waveforms Illustrating Acquire/Hold Mode	4-22
2-2. Power Cord Configurations	2-1	4-24. Simplified Diagram and Operation of S/H Circuit A	4-23
2-3. Model 3490A Dimensions	2-2	4-25. Simplified Diagram of S/H Circuit B	4-24
2-4. Installation of Isolated BCD Output and Remote Options	2-3	4-26. Dielectric Absorption Compensation	4-25
2-5. Data Output Connections, Option 021	2-4	4-27. Sample/Hole Logic Block Diagram	4-25
2-6. Remote Input Connections, Option 022	2-5	4-28. Block Diagram of S/H Timing and Trigger Circuits	4-26
2-7. Rear Input Connector and Cable	2-6	4-29. Sample/Hold Trigger Timing	4-26
2-8. Interface Bus Cables	2-6	4-30. Sample/Hold Measurement Sequence	4-28
2-9. Hewlett-Packard Interface Bus Connections	2-7	4-31. Sample/Hold Simplified Diagram and Measurement Sequence	4-29
2-10. Trigger Connections, HP-IB Option 030	2-8	5-1. AC Voltmeter High Frequency Accuracy Test	5-2
2-11. Trigger Connections S/H Option 045	2-8	5-2. DC Common-Mode Rejection Test	5-3
3-1. Front and Rear Panel	3-0	5-3. AC Common-Mode Rejection Test	5-4
3-2. Connecting the Guard	3-2	5-4. AC Normal-Mode Rejection Test	5-5
3-3. Ohmmeter Input Connections	3-5	5-5. DC Voltmeter Input Resistance Test	5-5
3-4. External Trigger Sequence (Option 020)	3-5	5-6. AC Voltmeter Input Impedance Test	5-6
3-5. Option 021 Printout	3-6	5-7. Sample/Hold Response Test	5-7
3-6. Remote Program Sequence (Option 022)	3-7	5-8. External Reference Input Resistance Test	5-9
3-7. Position of Jumper Wires on Outguard Mother Board Assembly A31	3-8	5-9. Location of Adjustments, Standard 3490A	5-14
3-8. Timing Diagram, 3490A Addressed to Listen	3-11	5-10. Location of Sample/Hold Adjustments	5-17
3-9. Timing Diagram, 3490A Addressed to Talk	3-12	5-11. Location of Ratio Adjustments	5-18
3-10. Example of Marked Card Programming	3-15	6-1. Chassis Parts	6-30
3-11. Typical Response to a Step Input Voltage	3-18	6-2. Binding Post Assembly	6-31
3-12. Digitizing a Ramp	3-19	6-3. Switch Assembly	6-31
3-13. Using Delayed-Sweep Oscilloscope in Ramp Linearity Measurements	3-20	7-1. Switching Inputs to A2U2	7-3
3-14. Filter Output Measurement	3-20	7-2. Switching Outputs of A1U401	7-3
3-15. Measurement of a Step Input	3-21	7-3. Sample/Hold Assembly	7-7
3-16. Ratio Input Connections	3-21	7-4. General Troubleshooting Tree	7-11/7-12
4-1. Dual-Slope Integration	4-1	7-5. DC Analog Troubleshooting Tree	7-13/7-14
4-2. Basic Diagram and Operation	4-2	7-6. AC Converter Troubleshooting Tree	7-15/7-16
4-3. Simplified Diagram, DC Amplifier	4-3	7-7. Ohms Converter Troubleshooting Tree	7-17/7-18
4-4. Measurement Sequence	4-4	7-8. Display Troubleshooting Tree	7-19/7-20
4-5. Simplified Diagram, Integrator Circuits	4-6	7-9. Logic Test Troubleshooting Tree	7-21/7-22
4-6. Simplified Diagram, AC Converter	4-7	7-10. Logic Clock Troubleshooting Tree	7-23/7-24
4-7. Simplified Diagram, Ohms Converter	4-8	7-11. Data Output Troubleshooting Tree Option 021	7-25/7-26
4-8. Block Diagram, Clock and Counters	4-9	7-12. Remote Troubleshooting Tree, Option 022	7-27/7-28
4-9. Typical State Machine Block Diagram	4-9	7-13. HP-IB I/O Troubleshooting Tree Option 030	7-29/7-30
4-10. Block Diagram, Main Logic ASM Flow Chart	4-10	7-14. Sample/Hold General Troubleshooting Tree	7-31/7-32
4-11. Block Diagram, Main Logic Circuits	4-11	7-15. Sample/Hold Logic Troubleshooting Tree	7-33/7-34
4-12. Block Diagram, Qualifier Multiplexer	4-12	7-16. Ratio Troubleshooting Tree	7-35
4-13. Simplified Diagram, Reference and Ratio Circuits	4-13	7-17. Location of Assemblies	7-36
4-14. Simplified Diagram, External Reference Circuits	4-14	7-18. 3490A Block Diagram	7-37
4-15. Input Bias Compensation	4-15	7-19. Reference Designations	7-38
4-16. Reference Polarity Logic	4-15	7-20. Schematic Diagram, DC Amplifier and Switching Circuits, A1, A2	7-39/7-40
4-17. Power Supply Block Diagram	4-16	7-21. Schematic Diagram, Integrator and Zero Detect Circuits, A1	7-41/7-42
4-18. Data Output Timing Diagram (Option 021)	4-18		
4-19. Remote Control Timing Diagram (Option 022)	4-19		
4-20. Typical Bus System	4-20		
4-21. Sample/Hold Circuit Position	4-22		
4-22. Waveforms Illustrating Track/Hold Mode	4-22		

LIST OF ILLUSTRATIONS (Cont'd)

Figure	Page	Figure	Page
7-22. Schematic Diagram, Reference and Ratio Circuits, A1, A13	7-43/7-44	7-36. Block Diagram, 3490A HP-IB I/O Circuits	7-71/7-72
7-23. Schematic Diagram, Clock and Counters, A1	7-47/7-48	7-37. Schematic Diagram, Inguard Program and ROM Assy's, A34, A36	7-73/7-74
7-24. Schematic Diagram, Main Logic, A1	7-45/7-46	7-38. Schematic Diagram, HP-IB Isolation Assemblies, A30, A35	7-75/7-76
7-25. Schematic Diagram, DC Switching Logic, A1	7-49/7-50	7-39. Schematic Diagram, Outguard Data and ROM Assemblies, A32, A33	7-77/7-78
7-26. Schematic Diagram, Power Supplies, A1, A8	7-51/7-52	7-40. Schematic Diagram, Outguard Mother Board, A31	7-79/7-80
7-27. Schematic Diagram, Display, A3	7-53/7-54	8-1. Schematic Diagram, A11 Assembly Serial No. 1211A01155 and Lower	8-3
7-28. Schematic Diagram, Function, Range and Sample Rate Switches, A5	7-55/7-56	8-2. Component Location, A11, Serial No. 1211A01155 and Lower	8-4
7-29. Schematic Diagram, AC Converter, A6	7-57/7-58	8-3. Optical Isolator Identification	8-4
7-30. Schematic Diagram, Ohms Converter, A7	7-59/7-60	8-4. A1 Component Locator	8-5
7-31. Schematic Diagram, External Trigger Circuits, A8, A22, A29, A37	7-61/7-62	8-5. A1 Schematic Diagrams	8-5
7-32. Schematic Diagram, Data Output Option 021, A9, A10, A15	7-63/7-64	8-6. A3 Display Board, Schematic and Troubleshooting Tree	8-7/8-8
7-33. Schematic Diagram, Remote Input Option 022, A11, A12, A17	7-65/7-66	8-7. A6 Schematic Diagram 12	8-9
7-34. Schematic Diagram, Sample/Hold Analog Circuits, A27	7-67/7-68	8-8. Binding Post Assembly	8-10
7-35. Schematic Diagram, Sample/Hold Logic Circuits, A28	7-69/7-70	8-9. A1 Schematic Diagram 5	8-11/8-12

LIST OF TABLES

Table	Page	Table	Page
1-1. Specifications	1-3	5-1. Recommended Test Equipment	5-0
1-2. General Information	1-5	5-2. DC Voltmeter Accuracy	5-1
2-1. Option 050 and Option 060 Part Changes	2-3	5-3. AC Voltmeter Accuracy	5-3
2-2. Hewlett-Packard Interface Bus Connectors	2-7	5-4. Ohmmeter Accuracy	5-3
3-1. Maximum Voltages	3-2	5-5. Alternate Ohmmeter Accuracy Test	5-3
3-2. Sample Rate and Response Time	3-4	5-6. Sample/Hold DC Accuracy Check	5-6
3-3. Distortion Error	3-4	5-7. DC/DC Ratio Accuracy Test	5-7
3-4. Ohmmeter Current	3-5	5-8. AC/DC Ratio Accuracy Test	5-8
3-5. HP-IB Signal Mnemonics	3-7	5-9. Power Supply Voltages	5-15
3-6. Address Codes	3-9	5-10. Ohmmeter Adjustment	5-16
3-7. Program Codes	3-10	6-1. Replaceable Parts	6-2
3-8. Ability of Sample/Hold to Digitize a Ramp or Sine Wave	3-17	7-1. Power Supply Voltages and Current Limit Values	7-1
3-9. Initiating S/H Measurements By External Triggering	3-17	7-2. Power Supply Jumper Wires	7-2
3-10. Maximum Acquisition (Settling) Time for Full-Range Step Input	3-18	7-3. AC Reed Relay Checks	7-4
3-11. Ratio Polarity Display	3-22	7-4. Component Spacing	7-4
4-1. AC Amplifier Ranging	4-7	7-5. Data Output Troubleshooting Tips	7-5
4-2. Polarity in Ratio Measurements	4-16	7-6. Alphabetical Listing of 3490A Mnemonics	7-10
4-3. Analog Tests	4-16	7-7. Alphabetical Listing of 3490A HP-IB I/O Mnemonics	7-71/7-72
4-4. Acquire/Hold Delay	4-22	8-1. Manual Backdating Changes	8-1
4-5. Gain Delay Relationship	4-26	8-2. Optical Isolators and Associated Components	8-4
		8-3. A3 Replaceable Parts	8-6

SECTION I

GENERAL INFORMATION

1-1. INTRODUCTION.

1-2. The Model 3490A Multimeter makes ac voltage, dc voltage, and resistance measurements with 5-digit resolution. It is capable of overrange measurements up to 120% of range on all except the 1000 V ac and dc ranges. Polarity selection and display are automatic. Range selection is manual or automatic over all ranges on all functions. Options are available to provide data output, remote programming, sample-and-hold measurements, and ratio measurements.

1-3. This manual contains installation and operating instructions as well as maintenance information for the Model 3490A Multimeter. Instrument specifications and procedures for verifying proper operation are included. Procedures are also included for adjusting the instrument to its performance specifications. Schematic diagrams, the theory of operation, and troubleshooting information are provided for use in maintaining the instrument.

1-4. This section of the manual contains the performance specifications for the Model 3490A and lists the available options. It also lists the accessories supplied with the Model 3490A and additional accessories that are available. Instrument and manual identification information is also included.

1-5. SPECIFICATIONS.

1-6. Table 1-1 is a complete list of the Model 3490A critical specifications that are controlled by tolerances. Table 1-2 contains general information that describes the operating characteristics of the Model 3490A.

1-7. Any change in the specifications due to manufacturing, design, or traceability to the U.S. National Bureau of Standards will be listed on a manual change sheet included with this manual. The manual and manual change sheet supersede all previous information concerning specifications of the 3490A.

1-8. OPTIONS.

1-9. The following options are available to extend the usefulness of the Model 3490A:

- Option 020: BCD/Remote Expand
- ~ Option 021: Isolated Data Output (BCD)
- ~ Option 022: Isolated Remote Control
(Options 021 and 022 require Option 020)
- ~ Option 030: Hewlett-Packard Interface Bus I/O (HP-IB)

- Option 040 or 045: Sample-and-Hold
- Option 050: 3490A designed for operation on 50 Hz power source
- Option 060: 3490A designed for operation on 60 Hz power source
- Option 080: Ratio
- Option 080: Ratio
- Option 908: Rack Mount Kit, P/N 5060-8739
- Option 910: Additional Operating and Service Manual

1-10. ACCESSORIES SUPPLIED.

1-11. The following accessories are supplied with the Model 3490A and its option as shown.

Supplied with Option 020:	
Rear input cable	03490-61612
36-pin connector	
(mates with Remote connector, J7)	1251-0084
50-pin connector	
(mates with Data Output connector, J6)	1251-0086
Remote Jumper Assembly, A4	03490-66504
PC Extender (2 x 22)	5060-0630
Supplied with Option 030:	
14-pin connector	
(mates with Trigger connector, J11)	1251-0142
Remote Jumper Assembly, A4	03490-66504
Rear input cable	03490-61612
PC Extender (2 x 22)	5060-0630
Supplied with Option 040:	
S/H Analog Jumper Assembly, A24	03490-66524
S/H Logic Jumper Assembly, A25	03490-66525
PC Extender (2 x 10)	5060-6032
Supplied with Option 045:	
S/H Analog Jumper Assembly, A24	03490-66524
S/H Logic Jumper Assembly, A25	03490-66525
PC Extender (2 x 10)	5060-6032
14-pin connector	
(mates with Trigger connector, J11)	1251-0142
Supplied with Option 080:	
Ratio Jumper Assembly, A26	03490-66526
PC Extender (2 x 10)	5060-6032

1-12. ACCESSORIES AVAILABLE.

1-13. Several accessories are available for use with the Model 3490A. A service video tape, Product No. 90030C Option 705, will demonstrate use of self-test and front panel symptoms to isolate failures. The -hp- 11126A accessory provides a set of IC reference boards with

most of the 3490A logic IC's for use with the -hp- 10529A Logic Comparator. Using these boards with the Logic Comparator, a faulty IC can be isolated in seconds without removing it from the circuit. A spare parts set, -hp- 11127A, is available for the 3490A. This set contains the most critical components of the 3490A such as integrated circuits, transistors and reed relays. Three interface cables are available for the HP-IB Option 030. These cables are identical except for length.

- 10631A Interface cable, 3-ft.
- 10631B Interface cable, 6-ft.
- 10631C Interface cable, 12-ft.

An HP-IB Service Kit, -hp- Part No. 44090A, is available for troubleshooting the Hewlett-Packard Interface Bus I/O circuits. Also available is a cable, Product No. 562A-16C, for use with Option 021 and -hp- 5050B or 5055A Printers. Field installable Options 021 and 022 for units with Option 020 are available by accessory numbers 11121A and 11122A respectively.

1-14. Conversion of the 3490A to a rack-mounted

instrument can be accomplished by using rack mount kit, Accessory Number 03490-84411.

1-15. INSTRUMENT AND MANUAL IDENTIFICATION.

1-16. Instrument identification by serial number is located on the rear panel. Hewlett-Packard uses a two-section serial number consisting of a four-digit prefix and a five-digit suffix separated by a letter designating the country in which the instrument was manufactured. (A = U.S.A.; G = West Germany; J = Japan; U = United Kingdom.)

1-17. This manual applies to instruments with the serial numbers indicated on the title page. If changes have been made in the instrument since this manual was printed, a "Manual Changes" supplement supplied with the manual will define these changes. Be sure to record these changes in your manual. Backdating information in Section VIII adapts the manual to instruments with serial numbers lower than that shown on the title page. Part numbers for the manual and the microfiche copy of the manual are also shown on the title page.

<http://www.ebaman.com>

Table 1-1. Specifications.

DC VOLTAGE		Temperature Coefficient (0° C to 50° C): ± (0.002 % of reading + 0.001 % of range)/° C																																	
Full-Range Display: ± .100000 V ± 100.000 V ± 1.00000 V ± 1000.00 V ± 10.0000 V		Voltage Coefficient (1000 V range): Add 0.01 ppm per Volt/kHz to % of reading																																	
Overrange: 20 % on all ranges except 1000 V range		Input Impedance:																																	
Accuracy: ± (% of reading + % of range)		2 MΩ ± 1 % shunted by: < 65 pF without rear input terminal < 90 pF with rear input terminal																																	
	.1 V Range	1 V - 1000 V Ranges		OHMS																															
24 hours (23° C ± 1° C)	± (0.005 + 0.001)	± (0.004 + 0.001)		Full-Range Display: .100000 kΩ 1.00000 kΩ 10.0000 kΩ 100.000 kΩ 1000.00 kΩ 10000.0 kΩ																															
30 days (23° C ± 5° C)	± (0.01 + 0.005)	± (0.008 + 0.002)		Overrange: 20 % on all ranges Accuracy: ± (% of reading + % of range)																															
90 days (23° C ± 5° C)	± (0.01 + 0.005)	± (0.01 + 0.002)		<table border="1"> <thead> <tr> <th></th> <th>.1 kΩ Range</th> <th>1 kΩ - 100 kΩ Range</th> <th>1000 kΩ Range</th> <th>10,000 kΩ Range</th> </tr> </thead> <tbody> <tr> <td>24 hours (23° C ± 1° C)</td> <td>0.006 + 0.001</td> <td>0.005 + 0.001</td> <td>0.007 + 0.001</td> <td>0.075 + 0.001</td> </tr> <tr> <td>30 days (23° C ± 5° C)</td> <td>0.012 + 0.005</td> <td>0.01 + 0.002</td> <td>0.012 + 0.002</td> <td>0.035 + 0.002</td> </tr> <tr> <td>90 days (23° C ± 5° C)</td> <td>0.012 + 0.005</td> <td>0.012 + 0.002</td> <td>0.015 + 0.002</td> <td>0.005 + 0.002</td> </tr> <tr> <td>6 months (23° C ± 5° C)</td> <td>0.015 + 0.005</td> <td>0.015 + 0.002</td> <td>0.02 + 0.002</td> <td>0.04 + 0.002</td> </tr> <tr> <td>1 year (23° C ± 5° C)</td> <td>0.018 + 0.005</td> <td>0.018 + 0.002</td> <td>0.025 + 0.002</td> <td>0.04 + 0.002</td> </tr> </tbody> </table>			.1 kΩ Range	1 kΩ - 100 kΩ Range	1000 kΩ Range	10,000 kΩ Range	24 hours (23° C ± 1° C)	0.006 + 0.001	0.005 + 0.001	0.007 + 0.001	0.075 + 0.001	30 days (23° C ± 5° C)	0.012 + 0.005	0.01 + 0.002	0.012 + 0.002	0.035 + 0.002	90 days (23° C ± 5° C)	0.012 + 0.005	0.012 + 0.002	0.015 + 0.002	0.005 + 0.002	6 months (23° C ± 5° C)	0.015 + 0.005	0.015 + 0.002	0.02 + 0.002	0.04 + 0.002	1 year (23° C ± 5° C)	0.018 + 0.005	0.018 + 0.002	0.025 + 0.002	0.04 + 0.002
	.1 kΩ Range	1 kΩ - 100 kΩ Range	1000 kΩ Range	10,000 kΩ Range																															
24 hours (23° C ± 1° C)	0.006 + 0.001	0.005 + 0.001	0.007 + 0.001	0.075 + 0.001																															
30 days (23° C ± 5° C)	0.012 + 0.005	0.01 + 0.002	0.012 + 0.002	0.035 + 0.002																															
90 days (23° C ± 5° C)	0.012 + 0.005	0.012 + 0.002	0.015 + 0.002	0.005 + 0.002																															
6 months (23° C ± 5° C)	0.015 + 0.005	0.015 + 0.002	0.02 + 0.002	0.04 + 0.002																															
1 year (23° C ± 5° C)	0.018 + 0.005	0.018 + 0.002	0.025 + 0.002	0.04 + 0.002																															
6 months (23° C ± 5° C)	± (0.013 + 0.005)	± (0.013 + 0.002)		Temperature Coefficient (0° C to 50° C): 0.1 kΩ range: ± (0.001 % of reading + 0.0007 % of range)/° C 1 kΩ through 10,000 kΩ ranges (< 70% R.H. on 1000 kΩ and 10,000 kΩ ranges): ± (0.001 % of reading + 0.0003 % of range)/° C																															
1 year (23° C ± 5° C)	± (0.015 + 0.005)	± (0.015 + 0.002)		DATA OUTPUT (Option 021) BCD 1-2-4-8, High true or Low true logic code, selectable by internal switch																															
Temperature Coefficient (0° C to 50° C): 0.1 V Range: ± (0.001 % of reading + 0.0007 % of range)/° C 1 V through 1000 V Ranges: ± (0.001 % of reading + 0.0003 % of range)/° C		<table border="1"> <thead> <tr> <th></th> <th>High Level</th> <th>Low Level</th> </tr> </thead> <tbody> <tr> <td>Input Signals</td> <td>+ 3.9 V ± 1.5 V, 100 μA max.</td> <td>+ 0.3 V ± 0.3 V, 2 mA max.</td> </tr> <tr> <td>Output Signals</td> <td>+ 3.9 V ± 1.5 V, 400 μA max.</td> <td>+ 0.3 V ± 0.3 V, 15 mA max.</td> </tr> </tbody> </table>					High Level	Low Level	Input Signals	+ 3.9 V ± 1.5 V, 100 μA max.	+ 0.3 V ± 0.3 V, 2 mA max.	Output Signals	+ 3.9 V ± 1.5 V, 400 μA max.	+ 0.3 V ± 0.3 V, 15 mA max.																					
	High Level	Low Level																																	
Input Signals	+ 3.9 V ± 1.5 V, 100 μA max.	+ 0.3 V ± 0.3 V, 2 mA max.																																	
Output Signals	+ 3.9 V ± 1.5 V, 400 μA max.	+ 0.3 V ± 0.3 V, 15 mA max.																																	
Voltage Coefficient (1000 V range): Add 0.04 ppm/volt to % of reading.		REMOTE CONTROL (Option 022) Remote programming of range and function uses High true logic code.																																	
Effective Common-Mode Rejection (with 1 kΩ imbalance in either lead): AC: Option 050 (50 Hz power frequency): > 140 dB at 50 Hz ± 0.1 % Option 060 (60 Hz power frequency): > 140 dB at 60 Hz ± 0.1 % DC: > 140 dB		<table border="1"> <thead> <tr> <th></th> <th>20 Hz</th> <th>50 Hz</th> <th>100 kHz*</th> <th>250 kHz</th> </tr> </thead> <tbody> <tr> <td>24 hours (23° C ± 1° C)</td> <td>0.32 + 0.05</td> <td>0.09 + 0.025</td> <td>0.7 + 0.06</td> <td></td> </tr> <tr> <td>30 days (23° C ± 5° C)</td> <td>0.35 + 0.05</td> <td>0.1 + 0.025</td> <td>0.75 + 0.06</td> <td></td> </tr> <tr> <td>90 days (23° C ± 5° C)</td> <td>0.35 + 0.05</td> <td>0.1 + 0.025</td> <td>0.75 + 0.06</td> <td></td> </tr> <tr> <td>6 months (23° C ± 5° C)</td> <td>0.4 + 0.06</td> <td>0.1 + 0.03</td> <td>0.75 + 0.07</td> <td></td> </tr> <tr> <td>1 year (23° C ± 5° C)</td> <td>0.45 + 0.07</td> <td>0.12 + 0.035</td> <td>0.75 + 0.08</td> <td></td> </tr> </tbody> </table>					20 Hz	50 Hz	100 kHz*	250 kHz	24 hours (23° C ± 1° C)	0.32 + 0.05	0.09 + 0.025	0.7 + 0.06		30 days (23° C ± 5° C)	0.35 + 0.05	0.1 + 0.025	0.75 + 0.06		90 days (23° C ± 5° C)	0.35 + 0.05	0.1 + 0.025	0.75 + 0.06		6 months (23° C ± 5° C)	0.4 + 0.06	0.1 + 0.03	0.75 + 0.07		1 year (23° C ± 5° C)	0.45 + 0.07	0.12 + 0.035	0.75 + 0.08	
	20 Hz	50 Hz	100 kHz*	250 kHz																															
24 hours (23° C ± 1° C)	0.32 + 0.05	0.09 + 0.025	0.7 + 0.06																																
30 days (23° C ± 5° C)	0.35 + 0.05	0.1 + 0.025	0.75 + 0.06																																
90 days (23° C ± 5° C)	0.35 + 0.05	0.1 + 0.025	0.75 + 0.06																																
6 months (23° C ± 5° C)	0.4 + 0.06	0.1 + 0.03	0.75 + 0.07																																
1 year (23° C ± 5° C)	0.45 + 0.07	0.12 + 0.035	0.75 + 0.08																																
AC Normal-Mode Rejection: Option 050 (50 Hz power frequency): > 50 dB at 50 Hz ± 0.1 % Option 060 (60 Hz power frequency): > 50 dB at 60 Hz ± 0.1 %		* Frequencies greater than 100 kHz specified on 1 V and 10 V ranges only.																																	
Input Resistance: 0.1 V through 10 V ranges (< 70% R.H.): > 2 × 10 ¹⁰ Ω 100 V and 1000 V ranges: 10 MΩ ± 0.15 %		AC VOLTAGE Full-Range Display: 1.00000 V 10.0000 V 100.000 V 1000.00 V Overrange: 20 % on all ranges except 1000 V range Frequency Range: 20 Hz to 250 kHz (Guard shorted to Low), 10 ⁷ maximum Volt-Hertz product Accuracy: ± (% of reading + % of range) Input levels above 1 % of range Guard must be connected to Low																																	

Table 1-1. Specifications (Cont'd).

<p>RATIO (Option 080)</p> <p>Ratio Measurement Input Configuration: 3 wire; External Reference Low is common with Input Low. External Reference High may be positive or negative with respect to Low.</p> $\text{Ratio} = \frac{\text{Input}}{\text{Ext. Ref.}}$ <p>External Reference Input Resistance: $> 10^7 \Omega$</p> <p>DC/DC Measurement Accuracy:</p> $\pm (\text{A}\% \text{ of Reading} + \text{B}\% \text{ of Input Range} + \frac{\text{Ext. Ref. Range}}{\text{Ext. Ref. Voltage}} \times \text{C}\% \text{ of Input Range})$	<p>External Reference Ranges: 1 V: $\pm 0.1 \text{ V}$ to $\pm 1.2 \text{ V}$ 10 V: $\pm 1 \text{ V}$ to $\pm 12 \text{ V}$ (1 V range should be used for greater accuracy if the Ext. Ref. voltage is between 1 V and 1.2 V.)</p> <p>Input Ranges: DC: 0.1 V to 1000 V AC: 1 V to 1000 V</p>																																																																																				
<table border="1" style="width: 100%; border-collapse: collapse;"> <thead> <tr> <th rowspan="3"></th> <th rowspan="3">Ext. Ref. Range</th> <th colspan="9">Input Range</th> </tr> <tr> <th colspan="3">.1 V</th> <th colspan="3">1 V, 10 V</th> <th colspan="3">100 V, 1000 V</th> </tr> <tr> <th>A</th> <th>B</th> <th>C</th> <th>A</th> <th>B</th> <th>C</th> <th>A</th> <th>B</th> <th>C</th> </tr> </thead> <tbody> <tr> <td>24 hours ($23^\circ\text{C} \pm 1^\circ\text{C}$)</td> <td>10 V 1 V</td> <td>.003 .003</td> <td>.001 .002</td> <td>.002 .002</td> <td>.002 .002</td> <td>.001 .002</td> <td>.002 .002</td> <td>.003 .005</td> <td>.001 .003</td> <td>.002 .002</td> </tr> <tr> <td>30 days ($23^\circ\text{C} \pm 5^\circ\text{C}$)</td> <td>10 V 1 V</td> <td>.007 .008</td> <td>.005 .015</td> <td>.002 .003</td> <td>.002 .003</td> <td>.003 .012</td> <td>.002 .003</td> <td>.005 .006</td> <td>.003 .012</td> <td>.002 .003</td> </tr> <tr> <td>90 days ($23^\circ\text{C} \pm 5^\circ\text{C}$)</td> <td>10 V 1 V</td> <td>.007 .008</td> <td>.005 .015</td> <td>.002 .003</td> <td>.002 .003</td> <td>.003 .012</td> <td>.002 .003</td> <td>.006 .007</td> <td>.003 .012</td> <td>.002 .003</td> </tr> <tr> <td>6 months ($23^\circ\text{C} \pm 5^\circ\text{C}$)</td> <td>10 V 1 V</td> <td>.007 .008</td> <td>.005 .015</td> <td>.002 .003</td> <td>.002 .003</td> <td>.003 .012</td> <td>.002 .003</td> <td>.007 .008</td> <td>.003 .012</td> <td>.002 .003</td> </tr> <tr> <td>1 year ($23^\circ\text{C} \pm 5^\circ\text{C}$)</td> <td>10 V 1 V</td> <td>.007 .008</td> <td>.005 .015</td> <td>.002 .004</td> <td>.003 .004</td> <td>.003 .012</td> <td>.002 .004</td> <td>.008 .009</td> <td>.003 .012</td> <td>.002 .004</td> </tr> </tbody> </table> <p>Notes:</p> <ol style="list-style-type: none"> On the 1000 V range, add 0.04 PPM/volt to the % of reading specification. EMF's generated external to the 3490A may be compensated to achieve the % of range accuracy specified by utilizing the rear panel Thermal Adjust provided. 			Ext. Ref. Range	Input Range									.1 V			1 V, 10 V			100 V, 1000 V			A	B	C	A	B	C	A	B	C	24 hours ($23^\circ\text{C} \pm 1^\circ\text{C}$)	10 V 1 V	.003 .003	.001 .002	.002 .002	.002 .002	.001 .002	.002 .002	.003 .005	.001 .003	.002 .002	30 days ($23^\circ\text{C} \pm 5^\circ\text{C}$)	10 V 1 V	.007 .008	.005 .015	.002 .003	.002 .003	.003 .012	.002 .003	.005 .006	.003 .012	.002 .003	90 days ($23^\circ\text{C} \pm 5^\circ\text{C}$)	10 V 1 V	.007 .008	.005 .015	.002 .003	.002 .003	.003 .012	.002 .003	.006 .007	.003 .012	.002 .003	6 months ($23^\circ\text{C} \pm 5^\circ\text{C}$)	10 V 1 V	.007 .008	.005 .015	.002 .003	.002 .003	.003 .012	.002 .003	.007 .008	.003 .012	.002 .003	1 year ($23^\circ\text{C} \pm 5^\circ\text{C}$)	10 V 1 V	.007 .008	.005 .015	.002 .004	.003 .004	.003 .012	.002 .004	.008 .009	.003 .012	.002 .004
	Ext. Ref. Range			Input Range																																																																																	
				.1 V			1 V, 10 V			100 V, 1000 V																																																																											
		A	B	C	A	B	C	A	B	C																																																																											
24 hours ($23^\circ\text{C} \pm 1^\circ\text{C}$)	10 V 1 V	.003 .003	.001 .002	.002 .002	.002 .002	.001 .002	.002 .002	.003 .005	.001 .003	.002 .002																																																																											
30 days ($23^\circ\text{C} \pm 5^\circ\text{C}$)	10 V 1 V	.007 .008	.005 .015	.002 .003	.002 .003	.003 .012	.002 .003	.005 .006	.003 .012	.002 .003																																																																											
90 days ($23^\circ\text{C} \pm 5^\circ\text{C}$)	10 V 1 V	.007 .008	.005 .015	.002 .003	.002 .003	.003 .012	.002 .003	.006 .007	.003 .012	.002 .003																																																																											
6 months ($23^\circ\text{C} \pm 5^\circ\text{C}$)	10 V 1 V	.007 .008	.005 .015	.002 .003	.002 .003	.003 .012	.002 .003	.007 .008	.003 .012	.002 .003																																																																											
1 year ($23^\circ\text{C} \pm 5^\circ\text{C}$)	10 V 1 V	.007 .008	.005 .015	.002 .004	.003 .004	.003 .012	.002 .004	.008 .009	.003 .012	.002 .004																																																																											
<p>DC/DC Temperature Coefficient: $\pm (\% \text{ of Reading} + \% \text{ of Input Range})/^\circ\text{C}$</p> <table border="1" style="width: 100%; border-collapse: collapse; margin: 10px auto;"> <thead> <tr> <th rowspan="2">Ext. Ref. Range</th> <th colspan="3">Input Range</th> </tr> <tr> <th>.1 V</th> <th>1 V, 10 V</th> <th>100 V, 1000 V</th> </tr> </thead> <tbody> <tr> <td>10 V</td> <td>$\pm (0.0003 + 0.0007)$</td> <td>$\pm (0.0001 + 0.0004)$</td> <td>$\pm (0.0005 + 0.0004)$</td> </tr> <tr> <td>1 V</td> <td>$\pm (0.0004 + 0.002)$</td> <td>$\pm (0.0002 + 0.002)$</td> <td>$\pm (0.0006 + 0.002)$</td> </tr> </tbody> </table>		Ext. Ref. Range	Input Range			.1 V	1 V, 10 V	100 V, 1000 V	10 V	$\pm (0.0003 + 0.0007)$	$\pm (0.0001 + 0.0004)$	$\pm (0.0005 + 0.0004)$	1 V	$\pm (0.0004 + 0.002)$	$\pm (0.0002 + 0.002)$	$\pm (0.0006 + 0.002)$																																																																					
Ext. Ref. Range	Input Range																																																																																				
	.1 V	1 V, 10 V	100 V, 1000 V																																																																																		
10 V	$\pm (0.0003 + 0.0007)$	$\pm (0.0001 + 0.0004)$	$\pm (0.0005 + 0.0004)$																																																																																		
1 V	$\pm (0.0004 + 0.002)$	$\pm (0.0002 + 0.002)$	$\pm (0.0006 + 0.002)$																																																																																		
<p>DC/DC Measurement Accuracy Example: Input Voltage = 0.5 V; Input Range = 1 V Ext. Ref. Voltage = 0.5 V; Ext. Ref. Range = 1 V 30 day spec. = $\pm (0.003\% \text{ of Reading} + 0.012\% \text{ of Input Range}$ Ext. Ref. Range $+ \frac{\text{Ext. Ref. Range}}{\text{Ext. Ref. Voltage}} \times 0.003\% \text{ of Input Range})$</p> <p>Ratio Reading should be 1.00000 0.003% of Reading = 3 counts 0.012% of Input Range = 12 counts $\frac{1 \text{ V}}{.5 \text{ V}} \times 0.003\% \text{ of Input Range} = \underline{6 \text{ counts}}$ Total error tolerance = 21 counts Display should be 0.99979 to 1.00021</p>	<p>AC/DC Measurement Accuracy: 10 V Ext. Ref. Range: Same as AC Voltage accuracy 1 V Ext. Ref. Range: 24 hours ($23^\circ\text{C} \pm 1^\circ\text{C}$): Same as AC Voltage accuracy 30 days to 1 year ($23^\circ\text{C} \pm 5^\circ\text{C}$): Add 0.01 to % of Range AC Voltage accuracy (See Table 1-1 of main 3490A manual.)</p> <p>AC/DC Temperature Coefficient: 10 V Ext. Ref. Range: Same as AC Voltage temperature coefficient 1 V Ext. Ref. Range: Add 0.001 to % of Range in AC Voltage temperature coefficient specification (See Table 1-1 of main 3490A manual.)</p>																																																																																				

Table 1-1. Specifications (Cont'd.)

<p>SAMPLE/HOLD (Option 040/045)</p> <p>Full-range Display:</p> <p>± 1.0000 V ± 10.000 V ± 100.00 V ± 1000.0 V</p> <p>Sample/Hold measurement display is 4 full digits plus overrange "1".</p> <p>Overrange: 20 % on all ranges except 1000 V range.</p>	<p>Sample/Hold Measurement Accuracy (DC function, 1 V through 1000 V ranges):</p> <p style="text-align: right;">± (% of reading + % of range)</p> <p>24 hours (23^o C ± 1^o C) ± (0.01 + 0.015) 30 days (23^o C ± 5^o C) ± (0.01 + 0.015) 90 days (23^o C ± 5^o C) ± (0.01 + 0.015) 6 months (23^o C ± 5^o C) ± (0.02 + 0.015) 1 year (23^o C ± 5^o C) ± (0.02 + 0.015)</p> <p>Temperature Coefficient (0^o C to 50^o C): ± (0.002 % of reading + 0.001 % of range/^o C).</p>
---	---

Table 1-2. General Information.

<p>Maximum Input Voltages:</p> <p>Between Input High and Low: ± 1000 Vrms (± 1500 V peak) Between either Low terminal and Guard: ± 200 V Between Guard and Chassis: ± 500 V Between Ω Signal High and Low: ± 250 Vrms</p> <p>Range Selection: Manual, automatic, or Remote (Optional)</p> <p>Maximum Reading Rate (Minimum Sample Period* Per Reading):</p> <table border="1"> <thead> <tr> <th>Function</th> <th>Option 050</th> <th>Option 060</th> </tr> </thead> <tbody> <tr> <td>DC Volts</td> <td>240.2 ms + 5 ms</td> <td>200.1 ms + 4 ms</td> </tr> <tr> <td>AC Volts</td> <td>1.26s + .025s</td> <td>1.05s + .025s</td> </tr> <tr> <td>Ohms</td> <td></td> <td></td> </tr> <tr> <td>.1 k to 100 k</td> <td>240.2 ms + 5 ms</td> <td>200.1 ms + 4 ms</td> </tr> <tr> <td>1,000 k</td> <td>300.2 ms + 6 ms</td> <td>250.1 ms + 5 ms</td> </tr> <tr> <td>10,000 k</td> <td>660.3 ms + 12 ms</td> <td>550.2 ms + 10 ms</td> </tr> </tbody> </table> <p>*Sample Rate Control set to FAST position and instrument not in overload.</p> <p>Response Time (to within rated accuracy for a step input applied coincident with encode trigger):</p> <p>DC Volts: < 200 ms AC Volts: < 2 seconds Ohms: 0.1 k to 100 k ranges: < 200 ms 1000 k range: < 250 ms 10,000 k range: < 550 ms</p> <p>Ohms Terminal Characteristics:</p> <p>Maximum voltage across unknown resistance: 25 V in overload 13 V for valid reading</p> <p>Nominal current through unknown resistance: 0.1 k to 10 k ranges: 1 mA 100 k and 1000 k ranges: 10 μA 10,000 k range: 1 μA</p> <p>Overload protection: Non-destructive: ± 250 V Fuse destructive: ± 1000 V</p> <p>Power Requirements:</p> <p>100 V, 120 V, 220 V, or 240 V (+ 5%, - 10%); 48 Hz to 66 Hz</p> <p>Power Consumption: ≤ 60 VA with all options</p>	Function	Option 050	Option 060	DC Volts	240.2 ms + 5 ms	200.1 ms + 4 ms	AC Volts	1.26s + .025s	1.05s + .025s	Ohms			.1 k to 100 k	240.2 ms + 5 ms	200.1 ms + 4 ms	1,000 k	300.2 ms + 6 ms	250.1 ms + 5 ms	10,000 k	660.3 ms + 12 ms	550.2 ms + 10 ms	<p>Environmental Characteristics:</p> <p>Operating Temperature: 0^o C to 50^o C Humidity Range: < 95 % relative humidity, 0^o C to 40^o C Storage Temperature: - 20^o C to + 75^o C</p> <p>HEWLETT-PACKARD INTERFACE BUS (HP-IB) LOGIC LEVELS The HP-IB logic levels are TTL compatible, low true logic; i.e., True State = 0 V dc to + 0.4 V dc, False State = + 2.5 V dc to + 5 V dc.</p> <p>HEWLETT-PACKARD INTERFACE BUS (outguard) ground is isolated from inguard circuit common (input Low terminal) and chassis (power line) ground and may be floated a maximum of 40 V above chassis.</p> <p>SAMPLE/HOLD</p> <p>Acquisition Time (Settling time for a full-range step input):</p> <table border="1"> <thead> <tr> <th>Range</th> <th>Maximum Acquisition Time to within 0.01 % of Final Value</th> </tr> </thead> <tbody> <tr> <td>1 V</td> <td>512 μs</td> </tr> <tr> <td>10 V</td> <td>128 μs</td> </tr> <tr> <td>100 V</td> <td>512 μs</td> </tr> <tr> <td>1000 V</td> <td>128 μs</td> </tr> </tbody> </table> <p>Aperture Time (Delay between the time a Sample/Hold Trigger command is received and the time Amplifier A enters the Hold mode):</p> <p>Track/Hold: < 400 ns (typically 220 ns); cycle-to-cycle variation < ± 10 ns.</p> <p>Acquire/Hold:</p> <table border="1"> <thead> <tr> <th></th> <th>Option 050</th> <th>Option 060</th> </tr> </thead> <tbody> <tr> <td>1 V, 100 V ranges</td> <td>615 μs ± 400 ns</td> <td>512.6 μs ± 400 ns</td> </tr> <tr> <td>10 V, 1000 V ranges</td> <td>154 μs ± 400 ns</td> <td>128.4 μs ± 400 ns</td> </tr> </tbody> </table> <p>Sample/Hold Trigger Inputs:</p> <p>Sample/Hold TTL Trigger (dc coupled): Input must go from HIGH (≥ + 2.4 V) to LOW (≤ + 0.4 V) for at least 30 ns. Signal must be HIGH at least 600 μs prior to going LOW. Must be capable of sinking 1 mA.</p> <p>Sample/Hold AC Trigger (ac coupled): Negative-going leading edge of a pulse at least 30 ns wide and having an amplitude of 2 V to 200 V. Signal must be stable at least 2 μs prior to negative-going transition.</p>	Range	Maximum Acquisition Time to within 0.01 % of Final Value	1 V	512 μs	10 V	128 μs	100 V	512 μs	1000 V	128 μs		Option 050	Option 060	1 V, 100 V ranges	615 μs ± 400 ns	512.6 μs ± 400 ns	10 V, 1000 V ranges	154 μs ± 400 ns	128.4 μs ± 400 ns
Function	Option 050	Option 060																																							
DC Volts	240.2 ms + 5 ms	200.1 ms + 4 ms																																							
AC Volts	1.26s + .025s	1.05s + .025s																																							
Ohms																																									
.1 k to 100 k	240.2 ms + 5 ms	200.1 ms + 4 ms																																							
1,000 k	300.2 ms + 6 ms	250.1 ms + 5 ms																																							
10,000 k	660.3 ms + 12 ms	550.2 ms + 10 ms																																							
Range	Maximum Acquisition Time to within 0.01 % of Final Value																																								
1 V	512 μs																																								
10 V	128 μs																																								
100 V	512 μs																																								
1000 V	128 μs																																								
	Option 050	Option 060																																							
1 V, 100 V ranges	615 μs ± 400 ns	512.6 μs ± 400 ns																																							
10 V, 1000 V ranges	154 μs ± 400 ns	128.4 μs ± 400 ns																																							

Table 1-2. General Information (Cont'd.)

<p>SAMPLE HOLD (CONT'D)</p> <p>Sample/Hold AC Characteristics:</p> <p>Maximum rate of change of input voltage to maintain tracking: 2.5 % of range/μs on the 10 V and 1000 V ranges. 5 % of range/μs on the 1 V and 100 V ranges.</p> <p>Maximum dV/dt during digitization: 50 V/μs</p> <p>Minimum \pm 3 dB Bandwidth (external input terminals to Sample/Hold amplifiers):</p> <table border="0"> <tr> <td style="text-align: center;">Range</td> <td style="text-align: center;">\pm 3 dB Frequency</td> </tr> <tr> <td style="text-align: center;">1 V</td> <td style="text-align: center;">20 kHz</td> </tr> <tr> <td style="text-align: center;">10 V</td> <td style="text-align: center;">40 kHz</td> </tr> <tr> <td style="text-align: center;">100 V</td> <td style="text-align: center;">15 kHz</td> </tr> <tr> <td style="text-align: center;">1000 V</td> <td style="text-align: center;">20 kHz</td> </tr> </table> <p>Time Response Characteristics: The time response of Sample/Hold for any input waveform can be approximated by the equation:</p> $V_{S/H} = V_{in} + K_1 \frac{dV_{in}}{dt}$ <p>Similarly, the input waveform can be reconstructed from measured data by the equation:</p> $V_{in} = V_{S/H} - K_1 \frac{dV_{S/H}}{dt}$ <p>Where: $V_{S/H}$ = Displayed Sample/Hold measurement. V_{in} = 3490A input voltage. $\frac{dV_{in}}{dt}$ = Slope of any portion of an input waveform.</p>	Range	\pm 3 dB Frequency	1 V	20 kHz	10 V	40 kHz	100 V	15 kHz	1000 V	20 kHz	<p>$\frac{dV_{S/H}}{dt}$ = Slope of signal as measured in increments small enough that the waveform between measurement points approaches or achieves linearity.</p> <p>K_1 = Velocity factor. The typical factor for each range is as follows.</p> <table border="0"> <tr> <td style="text-align: center;">Range</td> <td style="text-align: center;">Typical Velocity Factor</td> </tr> <tr> <td style="text-align: center;">1 V</td> <td style="text-align: center;">- 10 μs</td> </tr> <tr> <td style="text-align: center;">10 V</td> <td style="text-align: center;">- 2 μs</td> </tr> <tr> <td style="text-align: center;">100 V</td> <td style="text-align: center;">- 3 μs</td> </tr> <tr> <td style="text-align: center;">1000 V</td> <td style="text-align: center;">+ 7 μs</td> </tr> </table> <p>RATIO</p> <p>Range Selection: External Reference Range: Manual Input Range: Manual, automatic, or remote (optional)</p> <p>Ratio Display: 1 V Ext. Ref. Range: Read ratio directly 10 V Ext. Ref. Range: Multiply display by 0.1</p> <p>Polarity Display (automatic): + for +DC/+DC or -DC/-DC - for +DC/-DC or -DC/+DC No polarity display for AC/DC</p> <p>Ratio Measurement Capability: Maximum Numerical Display: 120000 on any Input range Maximum Input Voltage: 1000 Vrms</p> <p>Maximum Reading Rate: DC/DC: Same as for dc voltage measurements AC/DC: Same as for ac voltage measurements</p> <p>Input Protection: 250 Vrms (\pm 400 V peak) continuous</p> <p>Environmental Requirements: 0°C to 40°C, < 95% relative humidity 0°C to 50°C maximum operating temperature range</p>	Range	Typical Velocity Factor	1 V	- 10 μ s	10 V	- 2 μ s	100 V	- 3 μ s	1000 V	+ 7 μ s
Range	\pm 3 dB Frequency																				
1 V	20 kHz																				
10 V	40 kHz																				
100 V	15 kHz																				
1000 V	20 kHz																				
Range	Typical Velocity Factor																				
1 V	- 10 μ s																				
10 V	- 2 μ s																				
100 V	- 3 μ s																				
1000 V	+ 7 μ s																				

SECTION II INSTALLATION AND INTERFACE

2-1. INTRODUCTION.

2-2. This section contains information and instructions necessary for installing and interfacing the Model 3490A Multimeter. Included are initial inspection procedures, power and grounding requirements, environmental information, installation instructions, interconnection procedures, and instructions for repackaging for shipment.

2-3. INITIAL INSPECTION.

2-4. This instrument was carefully inspected both mechanically and electrically before shipment. It should be free of marks or scratches and in perfect electrical order upon receipt. To confirm this, the instrument should be inspected for physical damage incurred in transit. If the instrument was damaged in transit, file a claim with the carrier. Check for supplied accessories (Paragraph 1-10) and test the electrical performance of the instrument using the performance test procedures outlined in Section V. If there is damage or deficiency, see the warranty in the front of this manual.

2-5. POWER REQUIREMENTS.

2-6. The Model 3490A can be operated from any power source supplying 100 V, 120 V, 220 V or 240 V (-10% +5%), 48 Hz to 66 Hz. Power dissipation is 60 W maximum. Refer to Paragraph 3-18 (Section III) for instrument turn-on procedure.

2-7. Before connecting ac power to the 3490A, make sure the rear panel line selector switches are set to correspond to the voltage of the available power line as shown in Figure 2-1. Also, be sure the proper fuse is installed.

2-8. POWER CORDS AND RECEPTACLES.

2-9. Figure 2-2 illustrates the standard configurations used for -hp- power cords. The -hp- part number directly above each drawing is the part number for an instrument power cord equipped with a connector of that configuration. If the appropriate power cord is not included with the instrument, notify the nearest -hp- Sales and Service Office and a replacement cord will be provided.

2-10. GROUNDING REQUIREMENTS.

2-11. To protect operating personnel, the National Electrical Manufacturer's Association (NEMA) recommends that the instrument panel and cabinet be grounded. The Model 3490A is equipped with a three conductor power cable which, when plugged into an appropriate receptacle, grounds the instrument. The offset pin on the power plug is the ground connection.

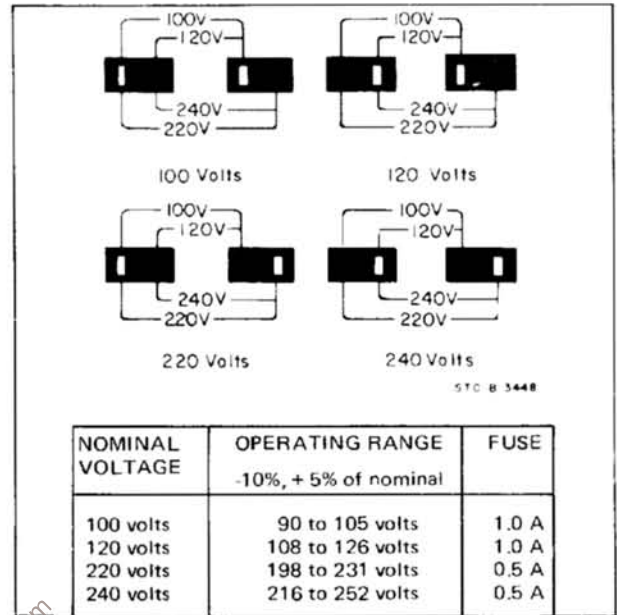

Figure 2-1. Line Voltage Selection.

2-12. To preserve the protection feature when operating the instrument from a two-contact outlet, use a three-contact to two-contact adapter and connect the wire on the adapter to power-line ground.

2-13. The 3490A power cord, power input receptacle and mating connectors meet the safety standards set forth by the International Electrotechnical Commission (IEC).

2-14. ENVIRONMENTAL REQUIREMENTS.

2-15. The Model 3490A requires no special cooling equipment if the instrument is mounted to allow free flow of air around all surfaces. The instrument may be

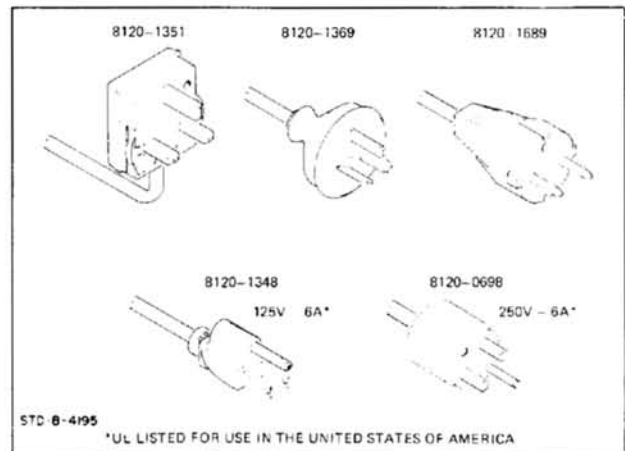

Figure 2-2. Power Cord Configurations.

operated where the ambient temperature is between 0° C and 40° C and the relative humidity is less than 95 %. The instrument may be stored at temperatures between - 20° C and + 75° C.

2-16. INSTALLATION.

2-17. Bench Use.

2-18. The Model 3490A is shipped with plastic feet and tilt stand in place, ready for use as a bench instrument. The front of the instrument may be elevated for convenience of operating and viewing by lowering the tilt stand. The plastic feet are shaped to permit placing the instrument on top of other full-module Hewlett-Packard instruments.

2-19. Rack Mounting.

2-20. The Model 3490A may be rack mounted using the rack mount kit, Option 908. Part Number 5060-8739 or Accessory Number 03490-84411. Instructions are included with the kit. The rack mount is an EIA standard width of 19 inches. When mounted using the rack mount kit, additional support must be provided at the rear of the instrument. The dimensions of the Model 3490A are shown in Figure 2-3.

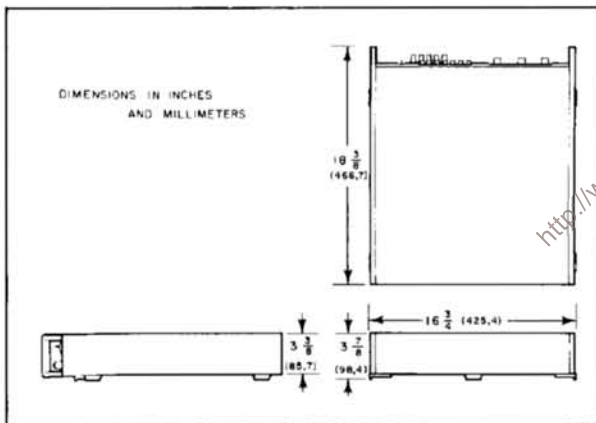

Figure 2-3. Model 3490A Dimensions.

2-21. INSTALLATION OF OPTIONS.

2-22. The Isolated Data Output (BCD) Option 021 and the Remote Option 022 may be installed in the Model 3490A only if the instrument was equipped at the factory with the BCD/Remote Expand Option 020.

2-23. Isolated Data Output Option 021 (-hp- 11121A).

2-24. Use the following procedure for installing the Isolated Data Output. If the Isolated Remote option is to be installed at the same time, refer also to Paragraph 2-25.

- Remove top cover and shield from the 3490A.
- Remove screws holding cover plate to instrument guard. This plate is located in left rear portion of

instrument between the Inguard Motherboard A1 and Outguard Motherboard A8.

- Install 03490-60306 Isolated BCD Module in the right opening in the instrument guard using screws provided (see Figure 2-4).

- If Isolated Remote (11122A) is not installed at this time, install cover plate 03490-04117 over the left opening in the guard. If Isolated Remote is to be installed, place the 03490-60308 Isolated Remote Module in the opening to the left of the BCD Module (see Figure 2-4).

- Insert the Isolated BCD Inguard PC Assembly 03490-66509 into Connector A1J8 and install Cable W4 between this Assembly and the inguard side of the Isolated BCD Module (see Figure 2-4).

- Insert the Isolated BCD Outguard PC Assembly 03490-66510 into Connector A8J9 and install Cable W5 between this Assembly and the outguard side of the Isolated BCD Module (see Figure 2-4).

- Make sure all boards are seated properly and all cables are securely inserted in their connectors.

- Replace top shield and top cover of the instrument.

2-25. Isolated Remote Option 022 (-hp- 11122A).

2-26. Use the following procedure for installing the Isolated Remote option. If the Isolated Data Output option is to be installed at the same time, refer also to Paragraph 2-23.

- Remove top cover and shield from the 3490A.
- Remove screws holding cover plate to instrument guard. This plate is located in left rear portion of the instrument between the Inguard Motherboard A1 and the Outguard Motherboard A8.

- Install 03490-60308 Isolated Remote Module in the left opening in the instrument guard using screws provided (see Figure 2-4).

- If Isolated BCD (11121A) is not installed at this time, install cover plate 03490-04117 over the right opening in the guard. If isolated BCD is to be installed, place the 03490-60306 Isolated BCD Module in the opening to the right of the Remote Module (see Figure 2-4).

- Remove the 03490-66504 Inguard Remote Jumper Board and insert the Isolated Remote Inguard PC Assembly 03490-66511 into Connector A1J7 and install Cable W6 between this assembly and the inguard side of the Isolated Remote Module (see Figure 2-4).

- Insert the Isolated Remote Outguard PC Assembly 03490-66512 into Connector A8J10 and install Cable

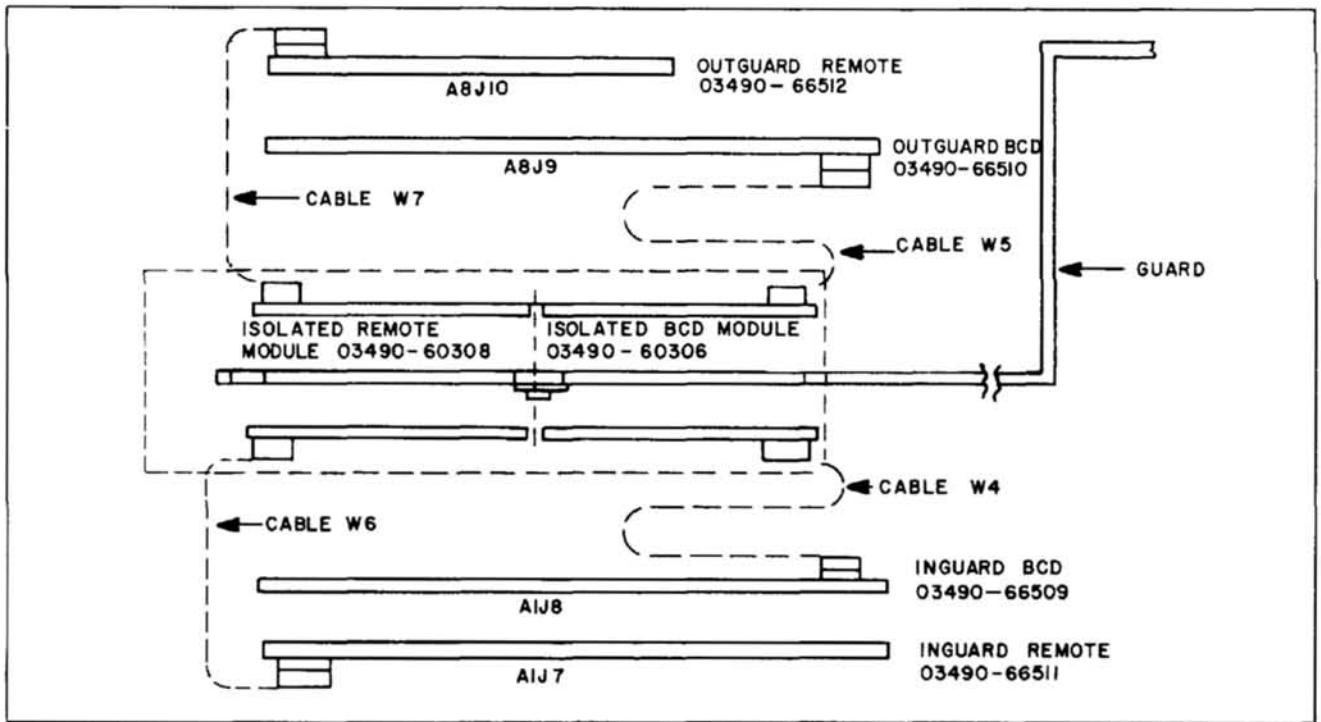

Figure 2-4. Installation of Isolated BCD Output and Remote Options.

W7 between this assembly and the outguard side of the Isolated Remote Module (see Figure 2-4).

- g. Make sure all boards are seated properly and all cables are securely inserted in their connectors.
- h. Replace top shield and top cover of the instrument.

2-27. Option 050 and Option 060.

2-28. A Model 3490A Option 050 (50 Hz power line) can be converted to an Option 060 (60 Hz power line) and vice versa. Only two parts are different for these two options. These are the Clock Oscillator crystal and the input resistor in the Integrator circuit. Table 2-1 shows the correct parts for each option.

Table 2-1. Option 050 and Option 060 Part Changes.

	Crystal		A1R207	
	Frequency	-hp- Part No.	Resistance	-hp- Part No.
Option 050	3.333 MHz	0410-0466	100 kΩ	0757-0465
Option 060	4.000 MHz	0410-0465	84.5 kΩ	0698-4510

2-29. INTERFACE CONNECTIONS.

2-30. Data Output Option 021.

2-31. Data Output connections and logic levels are shown in Figure 2-5. The measurement magnitude,

range, function, polarity and overload information is contained in ten four-bit groups of 1-2-4-8 BCD coded information. This information may be either HIGH true or LOW true, as selected by the HIGH/LOW switch on the Outguard Data Output Assembly, A10. In addition, a Data Flag output signal is provided which goes HIGH during a measurement sequence. The Printer Hold input line is HIGH true, while Hold and External Encode are LOW true. All input and output logic levels are as shown in Figure 2-5. Outguard ground (pin 50) is isolated from inguard circuit common and chassis (power line) ground and may be floated a maximum of 40 V above chassis. The mating connector for the rear panel Data Output connector J6 is -hp- Part No. 1251-0086 (Amphenol 57-30500-375). This connector is supplied with the Data Output option.

2-32. Remote Control Option 022.

2-33. Remote Control input and output lines and logic levels are shown in Figure 2-6. Range and function program lines are HIGH true, while all other input lines are LOW true. The Sample/Hold Mode, Delay and Trigger lines are for use with the Sample/Hold Option 040. The Program Flag output is HIGH during outguard-to-inguard transfer of program information, and the Data Flag output is HIGH during a measurement sequence. The Stretched Pulse Output is also intended for use with the Sample/Hold option. All input and output logic levels are as indicated in Figure 2-6. Outguard ground (pins 7, 11 and 12) is isolated from inguard common and chassis (power line) ground and may be floated a maximum of 40 V above chassis. The mating connector for the rear panel Remote Input

DATA OUTPUT CONNECTOR J6
OPTION 021

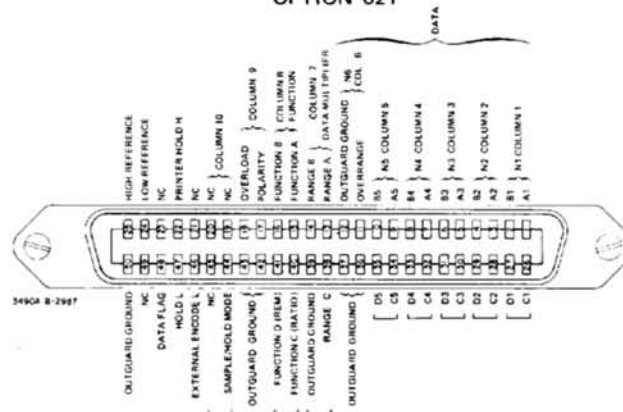

Mating Connector:
 -hp- Part No. 1251-0086
 Amphenol No. 57-30500-375

LOGIC LEVELS

Output Lines: HIGH = + 3.9 V ± 1.5 V, 400 μA max.
 LOW = + 0.3 V ± 0.3 V, 15 mA max.
 Input Lines: HIGH = + 3.9 V ± 1.5 V, 100 μA max.
 LOW = + 0.3 V ± 0.3 V, 2 mA max.

High Reference = + 5.3 V
 Low Reference = 0 V - Outguard ground

H after signal name means HIGH is true.
 L after signal name means LOW is true.

Outguard ground is isolated from inguard circuit common and chassis (power line) ground and may be floated up to 40 V above chassis.

DATA FLAG (Print Command Output)

Changes from LOW to HIGH at beginning of measurement and returns to LOW at completion of a reading cycle.

PRINTER HOLD

HIGH input level causes 3490A to stop automatic sampling until level returns to LOW.

HOLD

Continuous LOW input level disables automatic sampling and permits external triggering.

EXTERNAL ENCODE (Trigger)

When "Hold" mode is selected, LOW input level for minimum of 240 μs initiates one reading cycle. See Paragraph 3-64.

DIGITAL RECORDER PRINT CODES (Using -hp- 5050B Standard + or - 1248 Print Wheel)

Printer columns numbered from right to left. Columns 1 through 5 print numerical value of measurement. Coded output information may be either HIGH true or LOW true, as selected by the HIGH/LOW switch on the Outguard Data Output Assembly, A10. This switch must be set to correspond to the logic true input level required by the digital recorder used.

Column 6

NS Display	HIGH True		LOW True	
	Data DCBA	Print	Data DCBA	Print
0	LLLL	0	LLH	Ω
1	LLH	1	LLL	*

Column 7

Data Multiplier	HIGH True		LOW True	
	Range Bit DCBA	Print	Range Bit DCBA	Print
10 ⁻¹	LLH	1	LHHL	9
10 ⁻²	LLHL	2	LHLH	+
10 ⁻³	LLHH	3	LHLL	-
10 ⁻⁴	LHLL	4	LLHH	V
10 ⁻⁵	LHLH	5	LLHL	A
10 ⁻⁶	LHHL	6	LLH	Ω

Data Multiplier: N6 10⁻⁶, N5 10⁻⁵, N4 10⁻⁴, N3 10⁻³, N2 10⁻², N1 10⁻¹

Data times Data Multiplier gives measurement in volts or kilohms except for Ratio measurements.

Column 8

Function	HIGH True		LOW True	
	Function Bit DCBA	Print	Function Bit DCBA	Print
DC, Remote, Ratio	LLLL	0	HHHH	0
Ω, Remote, Ratio	LLH	1	HHH	1
AC, Remote, Ratio	LLHL	2	HHL	2
Test, Remote, Ratio	LLHH	3	HLL	3
DC, Remote	LHLL	4	HLH	4

Column 8 (Cont'd)

Function	HIGH True		LOW True	
	Function Bit DCBA	Print	Function Bit DCBA	Print
Ω, Remote	LHLH	5	HLHL	5
AC, Remote	LHHL	6	HLLH	6
Test, Remote	LHH	7	HLLL	7
DC, Ratio	HLLL	8	LHHH	8
Ω, Ratio	HLLH	9	LHHL	9
(not valid)				
AC, Ratio	HHLH	+	LHLH	+
Test, Ratio	HLHH	-	LHLL	-
DC	HLL	V	LLHH	V
Ω	HHL	A	LLHL	A
AC	HHL	Ω	LLH	Ω
Test	HHH	*	LLL	*

Column 9

Polarity, Overload	HIGH True		LOW True	
	Data DCBA	Print	Data DCBA	Print
+	LLLL	0	LLHH	V
-	LLH	1	LLHL	A
+ , OL	LLHL	2	LLLH	Ω
- , OL	LLHH	3	LLLL	*

Column 10

Sample/Hold Mode	HIGH True		LOW True	
	Data DCBA	Print	Data DCBA	Print
ON	HLHH	-	HHHH	0
OFF	HHH	*	HLHH	4

Figure 2-5. Data Output Connections, Option 021.

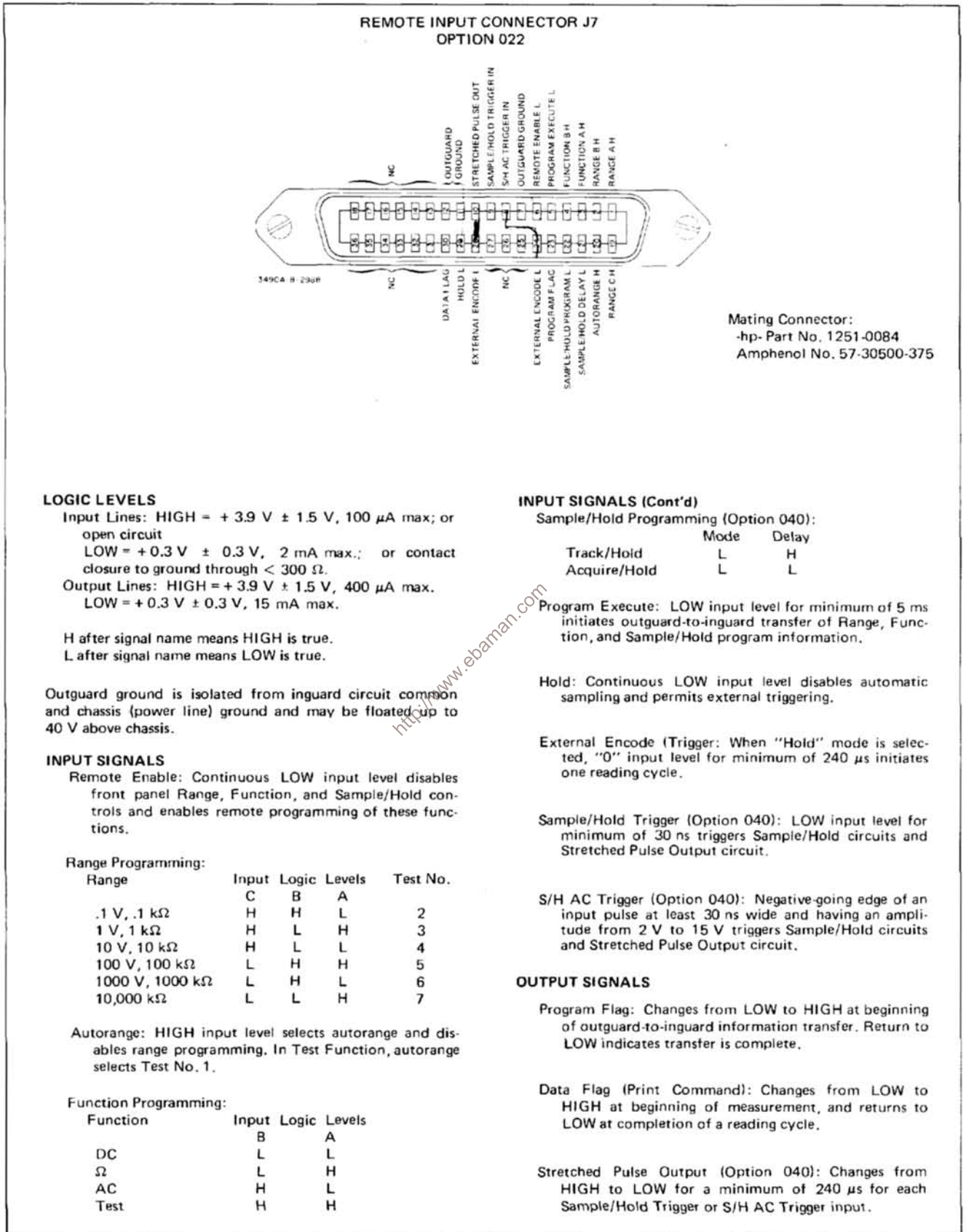

Figure 2-6. Remote Input Connections, Option 022.

connector J7 is -hp- Part No. 1251-0084 (Amphenol 57-30360-375). This connector is supplied with the Remote Control option.

2-34. Rear Input.

2-35. Options 020 and 030 provide a rear panel input connector in parallel with the front panel terminals. This connector is shown in Figure 2-7. The inner guard of the 3490A Rear Input connector is internally connected to pin B. Do not connect these points together externally. The mating connector for this rear panel input is -hp- Part No. 1251-1233, Component Manufacturing Service, Inc. Part No. A-1369. A six-foot cable, -hp- Part No. 03490-61612, is supplied with Options 020 and 030. This cable is terminated at one end by the rear input

mating connector; the other end is unterminated. Figure 2-7 also shows the wire colors in this cable.

2-36. Hewlett-Packard Interface Bus Connections.

2-37. Figure 2-9 shows the signal connections at the rear panel HP-IB connector, J12, and gives a brief description of each signal. Additional signal information is included in Section III, Operating Instructions (see Paragraph 3-90). The 10631A/B/C Interface Cables shown in Figure 2-8 are used to connect the instruments together. The connectors at either end of the cable are identical and consist of a plug which mates with the instrument rear panel connector or another cable, and a receptacle which will receive another cable plug. Instruments may then be paralleled as shown in Figure 4-20. The dual connector is not available as a separate unit because the hood is molded around the cable. The connectors listed in Table 2-2 mate with the rear panel connector or another cable. These do not provide the thumb screws for securing the connectors.

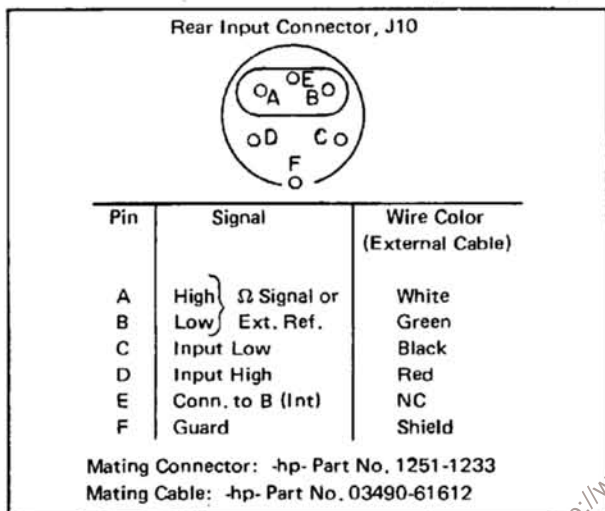

Figure 2-7. Rear Input Connector and Cable.

2-38. Interface Cable Length.

2-39. As many as 15 instruments can be connected in parallel to the same Hewlett-Packard Interface Bus; however, the following restrictions must be observed. Figure 4-20 shows the cabling for a typical Hewlett-Packard Interface Bus system.

1. The cable length between two instruments cannot exceed 12 feet.
2. When more than two instruments are connected in parallel, the cable length to each additional instrument cannot exceed 6 feet per unit.
3. The total cable length to all units cannot exceed 51 feet.

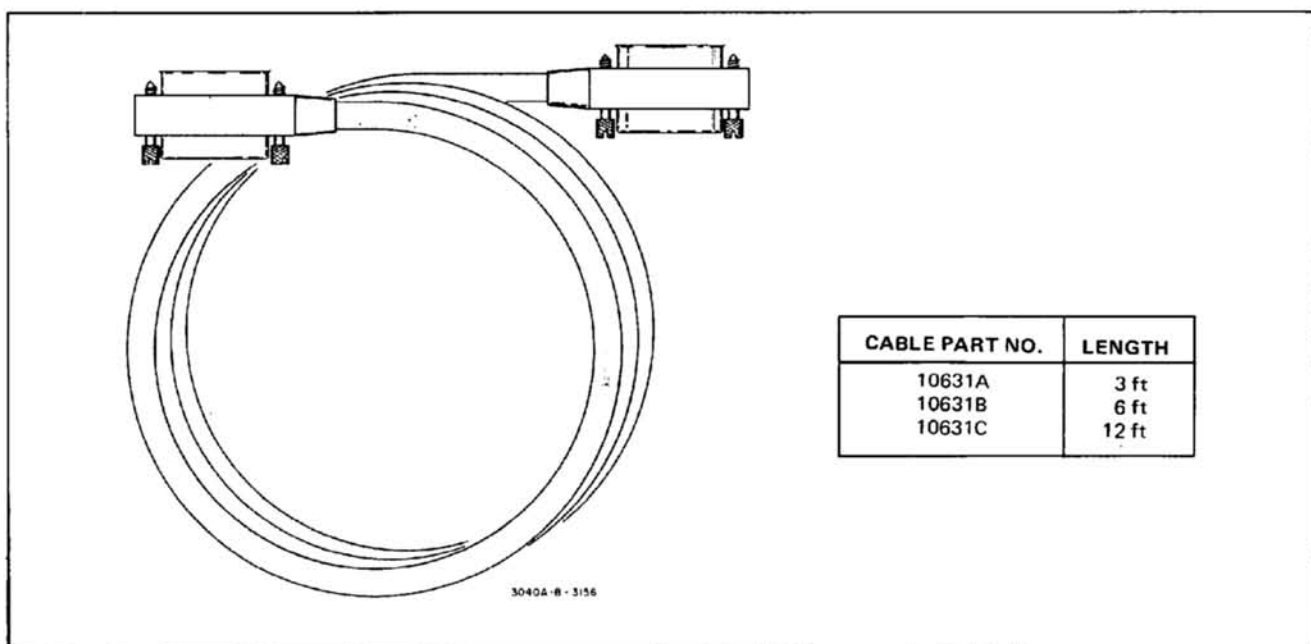

Figure 2-8. Interface Bus Cables.

Table 2-2. Hewlett-Packard Interface Bus Connectors.

Description	Mates with	-hp- Part No.	Amphenol No.
A. Cable to chassis plug with hood and clamp	Rear panel or with B or D.	1251-0293	57-30240
B. Cable to chassis Receptacle with hood and clamp	A or C	1251-0431	57-60240
C. Rack and panel plug	Rear panel or with B or D.	1251-0389	57-10240
D. Rack and panel Receptacle	A or C	1251-0388	57-20240

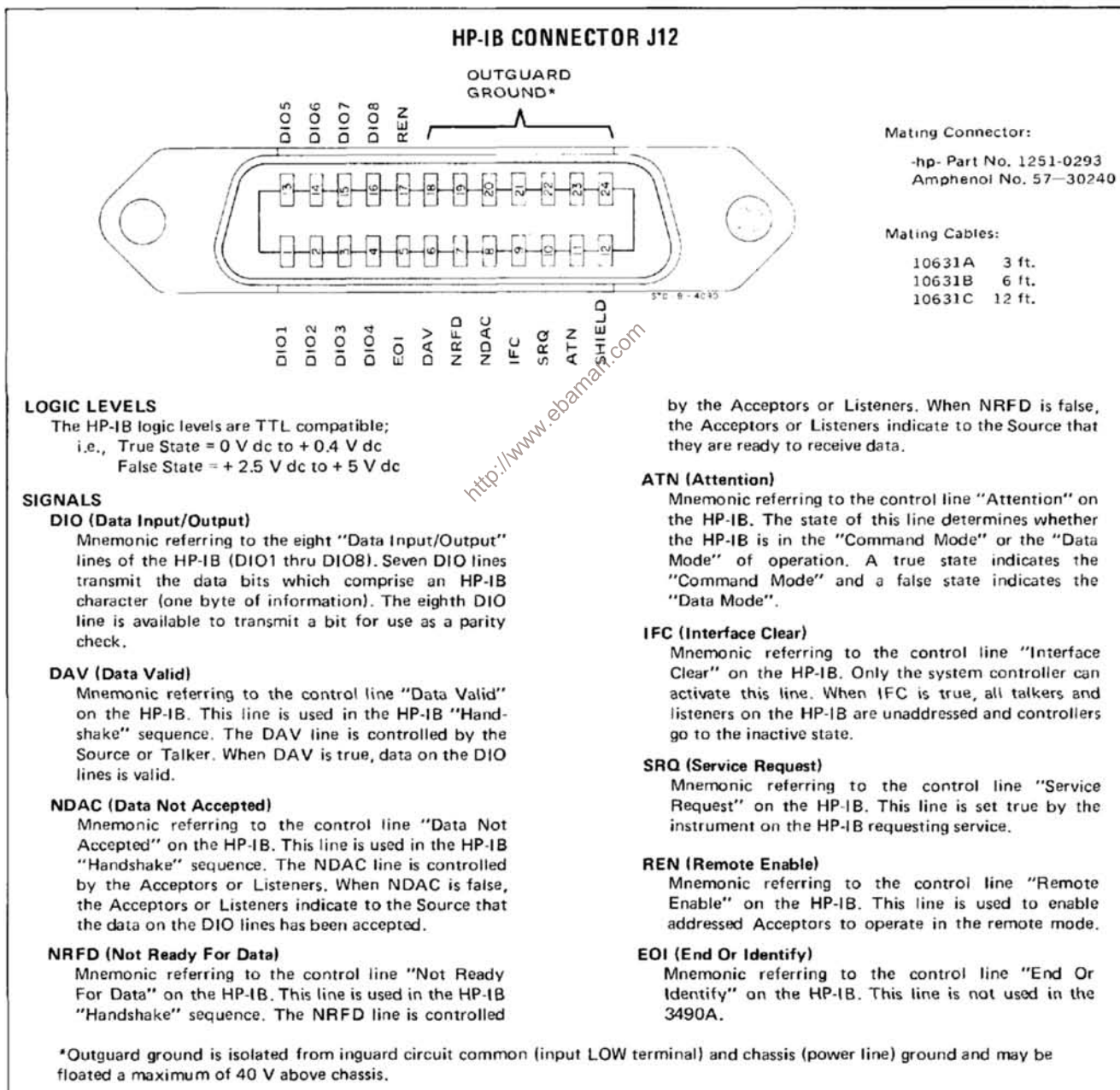

Figure 2-9. Hewlett-Packard Interface Bus Connections.

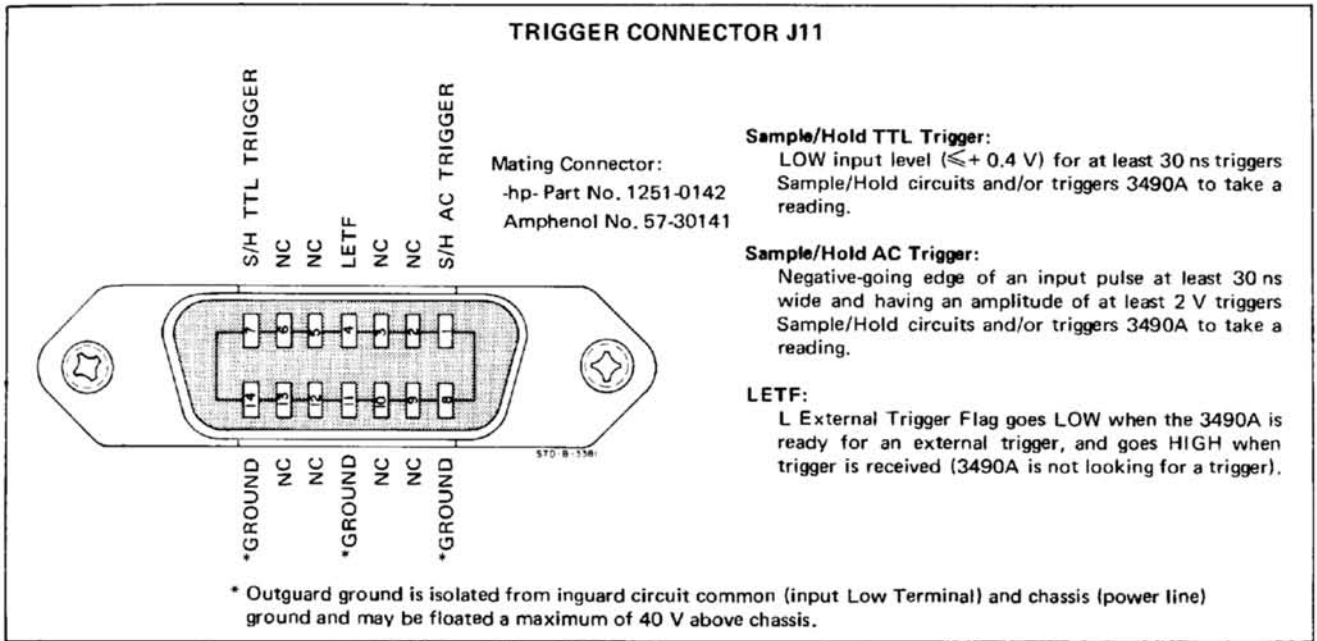

Figure 2-10. Trigger Connections, HP-IB Option 030.

2-40. Trigger Connections, HP-IB Option 030.

2-41. Figure 2-10 shows the rear panel Trigger connector, J11, and lists the External Trigger signals. The mating connector for J11 is -hp- Part No. 1251-0142 (Amphenol 57-30141).

Hold without Option 020 or Option 030. The mating connector for Trigger Connector J11 is -hp- Part No. 1251-0142 (Amphenol 57-30141).

2-42. Sample/Hold Connections, Option 040/045.

2-44. Sample/Hold with BCD Remote Expand Option 020. When Sample/Hold is included in an instrument with the BCD Remote Expand Option 020, the Sample/ Hold trigger connections are located on the Remote Input Connector, J7. Figure 2-6 shows this connector and describes the trigger signals. The mating connector

2-43. Option 045. Figure 2-11 shows the external trigger connections for Option 045, which is Sample/

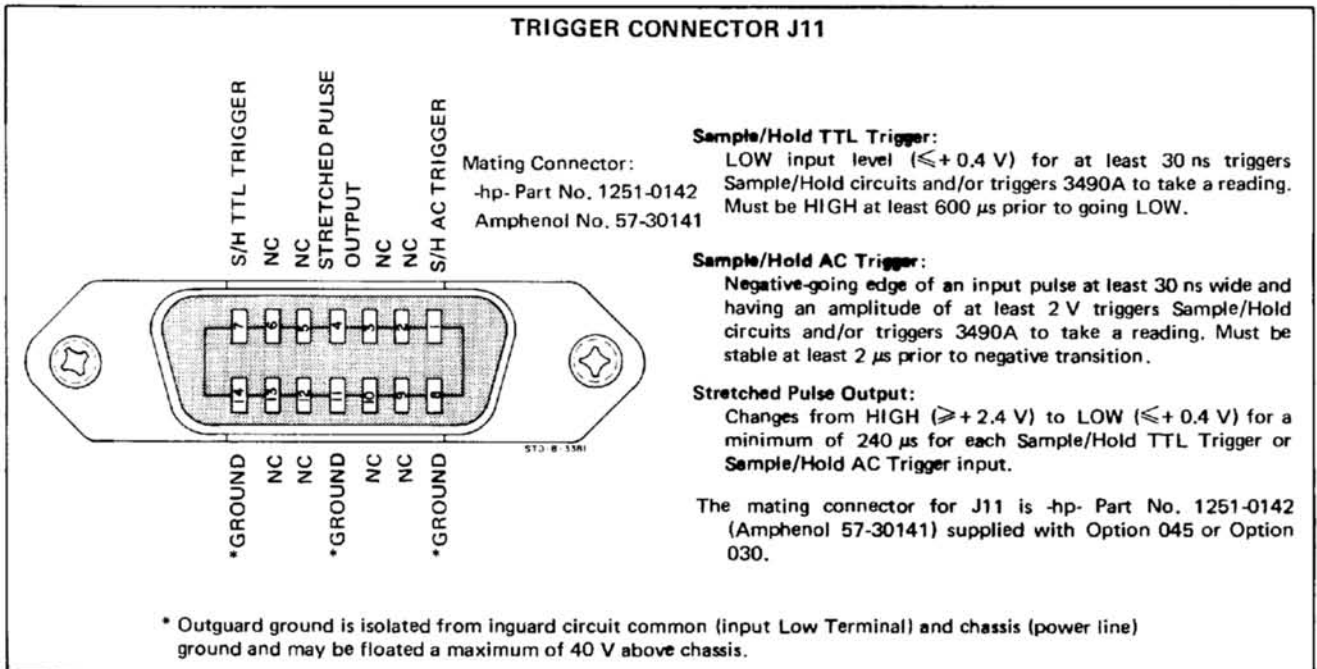

Figure 2-11. Trigger Connections S/H Option 045.

for J7 is -hp- Part No. 1252-0084 (Amphenol 57-30360-375).

2-45. Sample/Hold with HP-IB Option 030. Figure 2-10 shows the Trigger Connector, J11, and describes the trigger signals. The mating connector is -hp- Part No. 1251-0142 (Amphenol 57-30141).

2-46. REPACKAGING FOR SHIPMENT.

NOTE

If the instrument is to be shipped to Hewlett-Packard for service or repair, attach a tag to the instrument identifying the owner and indicating the service or repair to be accomplished. Include the model number and full serial number of the instrument. In any correspondence, identify the instrument by model number and full serial number. If you have any questions, contact your nearest -hp- Sales and Service Office.

2-47. The following is a general guide for repackaging the instrument for shipment. If the original container is available, place the instrument in the container with appropriate packing material and seal well with strong tape or metal bands. If the original container is not available, proceed as follows:

a. Wrap the instrument in heavy paper or plastic before placing in an inner container.

b. Place packing material around all sides of the instrument and protect panel face with cardboard strips or plastic foam.

c. Place the instrument and inner container in a heavy carton and seal with strong tape or metal bands.

d. Mark shipping container, "DELICATE INSTRUMENT," "FRAGILE," etc.

NOTE

If the instrument is to be shipped to Hewlett-Packard for service or repair, attach a tag to the instrument identifying the owner and indicating the service or repair to be accomplished. Include the model number and full serial number of the instrument. In any correspondence, identify the instrument by model number and full serial number. If you have any questions, contact your nearest -hp- Sales and Service Office.

<http://www.ebaman.com>

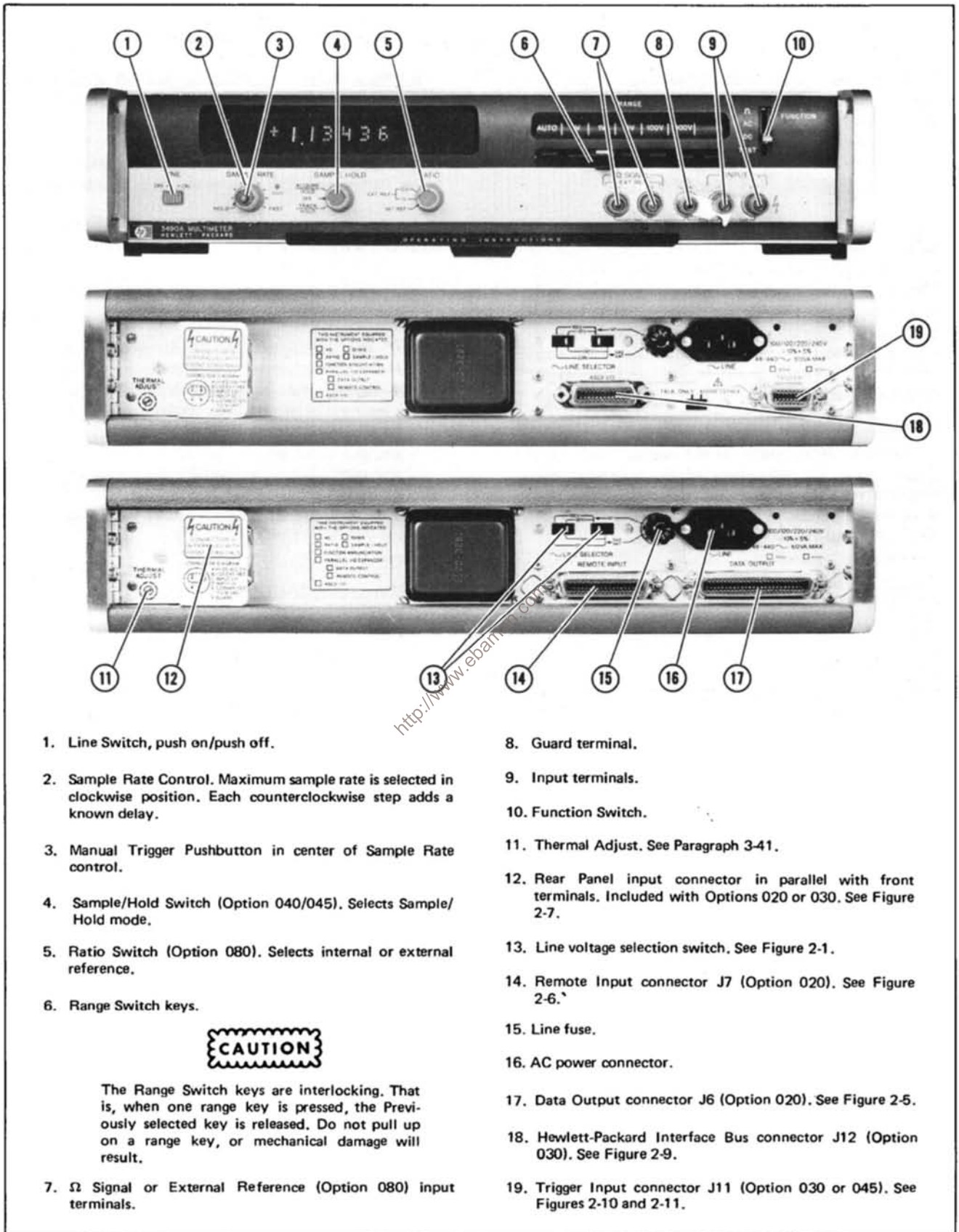

1. Line Switch, push on/push off.
2. Sample Rate Control. Maximum sample rate is selected in clockwise position. Each counterclockwise step adds a known delay.
3. Manual Trigger Pushbutton in center of Sample Rate control.
4. Sample/Hold Switch (Option 040/045). Selects Sample/Hold mode.
5. Ratio Switch (Option 080). Selects internal or external reference.
6. Range Switch keys.
7. Ω Signal or External Reference (Option 080) input terminals.
8. Guard terminal.
9. Input terminals.
10. Function Switch.
11. Thermal Adjust. See Paragraph 3-41.
12. Rear Panel input connector in parallel with front terminals. Included with Options 020 or 030. See Figure 2-7.
13. Line voltage selection switch. See Figure 2-1.
14. Remote Input connector J7 (Option 020). See Figure 2-6.
15. Line fuse.
16. AC power connector.
17. Data Output connector J6 (Option 020). See Figure 2-5.
18. Hewlett-Packard Interface Bus connector J12 (Option 030). See Figure 2-9.
19. Trigger Input connector J11 (Option 030 or 045). See Figures 2-10 and 2-11.

CAUTION

The Range Switch keys are interlocking. That is, when one range key is pressed, the previously selected key is released. Do not pull up on a range key, or mechanical damage will result.

Figure 3-1. Front and Rear Panel.

SECTION III

OPERATING INSTRUCTIONS

3-1. INTRODUCTION.

3-2. This section contains instructions for using the Model 3490A Multimeter to make dc voltage, ac voltage and resistance measurements. It also includes instructions for sample/hold and ratio measurements, remote control and data output. Basic operating instructions may be found on a pull-out card at the bottom edge of the 3490A front panel.

3-3. INSTRUMENT CAPABILITIES.

3-4. Standard Instrument.

3-5. The standard Model 3490A Multimeter makes dc voltage, ac voltage and resistance measurements with 5-digit resolution and up to 120 % of range on all ranges except 1000 Vac to dc. The 3490A has five dc voltage ranges, .1 V to 1000 V; 4 ac voltage ranges, 1 V to 1000 V; and six resistance ranges, 1 k Ω to 10,000 k Ω . Ranging may be manual or automatic. Polarity selection and display are automatic. A self-test feature is included which checks certain operations within the instrument.

3-6. Output and Remote Control Options.

3-7. Data Output Option 021 and Remote Control Option 022. Option 021 provides ten columns of binary coded decimal (BCD) output data. This data may be either HIGH true or LOW true, as selected by a slide switch on the outguard data output printed circuit assembly. With Option 022, the 3490A range and function may be programmed by LOW true input information. External triggering is possible with either option.

3-8. Hewlett-Packard Interface Bus I/O Option 030. The Hewlett-Packard Interface Bus I/O (HP-IB) option permits remote programming and data output on the same bus lines. The 3490A may be connected to a bus in parallel with several other instruments and controlled by a single controlling instrument. Remote control of range, function, Trigger mode and Sample/ Hold mode is possible with Option 030. The output data includes measurement status, function, polarity, magnitude and range, in the format given in Paragraph 3-1 26. Controlling instruments that may be used with the 3490A HP-IB option include the -hp- 9800A series calculators and the -hp- Model 3260A Marked Card Programmer.

3-9. Sample/ Hold Option 040 or 045.

3-10. The Sample/ Hold Option (040 or 045) enables the Model 3490A Multimeter to sample a changing input

voltage and hold that sample long enough to measure its amplitude. This permits pulse height measurements and digitization of changing waveforms such as ramps or sine waves. The external trigger circuits are isolated from the signal input Low terminal and from chassis ground, which allows the voltmeter to make guarded floating measurements. The designations used for the 3490A Sample/ Hold options are as follows:

When Sample/ Hold is installed in a 3490A with:

BCD/Remote Expand Option 020	Option 040
HP-IB Option 030	Option 040
Neither 020 or 030	Option 045

3-11. Ratio Option 080.

3-12. The 3490A equipped with Ratio Option 080 is capable of making three-wire dc-to-dc or ac-to-dc ratio measurement. Two External Reference ranges are provided, the 1 V range accepting reference voltages of ± 0.1 V to ± 1.2 V, and the 10 V range accepting voltages from ± 1 V to ± 12 V.

3-13. FRONT AND REAR PANEL DESCRIPTION.

3-14. Figure 3-1 shows the front and rear panel controls and connectors and gives a brief description of each. Some of the features shown are available only with certain options.

3-15. MAXIMUM INPUT VOLTAGES.

3-16. Table 3-1 lists the maximum allowable voltages between input terminals, and between the terminals and chassis. These maximum voltages are also shown on the front panel and must not be exceeded or damage to the instrument may result.

WARNING

If the 3490A has a rear input connector, the front and rear terminals are internally connected in parallel. If high voltages may be applied, always protect the open terminals. Be sure the rear input terminals are open before connecting an input to the front terminals and vice versa.

Table 3-1. Maximum Voltages.

	Maximum Voltage
Between Input HIGH and LOW	1000 Vrms
Between Ω Signal HIGH and LOW	250 Vrms
Between either LOW terminal and Guard	200 V peak
Between Guard and Chassis	500 V peak

3-17. GENERAL OPERATING INSTRUCTIONS.

3-18. Turn-On and Warm-Up.

3-19. Before connecting ac power to the 3490A, make sure the rear panel line selector switches are set to correspond to the voltage of the available power line as shown in Paragraph 2-5 and Figure 2-1.

3-20. Guarding.

3-21. Common-Mode Voltages. Common-mode voltages are those existing between the power line ground point of the source circuitry and that of the 3490A, and between the Low measurement point and power line ground of the source circuit. When current due to these voltages flows into the 3490A input terminals, some error in measurement results because of the voltage drop in the measuring circuit. In systems measurements, the resistance of long input leads may become significant. Wide separation between the 3490A power line ground point and the ground point of the source circuit may result in high common-mode voltage.

3-22. Guard Connection. Figure 3-2 illustrates three ways of connecting the 3490A Guard terminal to reduce errors caused by common-mode voltages. In example A, Guard is at practically the same potential as the Low measurement point, so any common-mode current flows through Guard and not through the measurement circuit. In example B, the 3490A Guard strap is connected to the Low terminal, placing both at the same potential. This allows common-mode current to flow through the input lead resistance R_b , causing some measurement error. This connection may be used if common-mode voltages are not expected to be a problem or if R_b is small (short leads). Example C is similar to A, except that connecting Guard in this manner allows any common-mode current generated between the Low measurement point and power line ground of the source circuit to flow in the measurement circuit. Guard should *always* be connected, either to the Low terminal or to a point in the source circuit as indicated. If the guard terminal is left open, common-mode voltages may exceed the Low-to-Guard breakdown rating and damage the 3490A.



The Guard Terminal must always be connected to Low or to a corresponding point in the source circuit or damage to the instrument may result.

3-23. Guarding Information. More detailed information on purpose and methods of guarding may be found in -hp- Application Note No. 123, "Floating Measurements and Guarding." This application note is available through your nearest -hp- Sales and Service Office.

3-24. Floating Measurements.

3-25. The Model 3490A is capable of making floating measurements. That is, the input Low terminal is not connected to chassis (power line) ground. The voltage between the guard terminal and chassis must not be greater than 500 V peak.

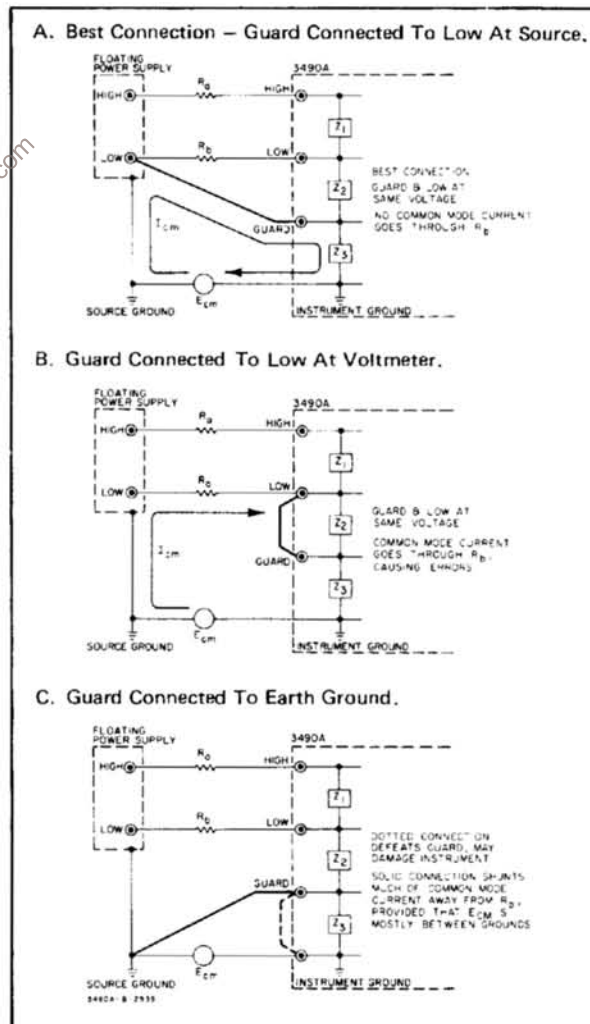

Figure 3-2. Connecting the Guard.

3-26. Overrange Measurements.

3-27. Measurements within rated accuracy are possible up to 120 % of range on all except the 1000 Vac or dc ranges. Overage inputs on these ranges would exceed the maximum allowable input voltage. The display includes the overrange "1" as the sixth digit.

3-28. Overload Indication.

3-29. If the measurement is 120 % of range or greater, the Overload "OL" annunciator will light. The numerical display will read 120000 to 120005.

3-30. Range Indication.

3-31. The 3490A display always reads in volts or kilohms (except in Ratio measurements), with the decimal point and range switch indicating the range selected. In autorange mode, the decimal point alone indicates range.

3-32. Function Indication.

3-33. In the standard 3490A, function is indicated only by the function switch position. If optional Remote control is in use, the "REM" annunciator lights to indicate that the front panel switches are disabled. An available special display assembly adds V, AC, K Ω and TST annunciators to indicate the function selected.

3-34. Autoranging.

3-35. In the autorange mode, upranging occurs at 120 % of range and downranging at 10 % of range. A measurement sequence is not completed unless the reading is on the proper range. For example, if the Sample Rate control is set to Hold and the Manual Trigger pushbutton depressed once, the 3490A will continue to sample until one reading is taken on the correct range. When the 3490A is changed to the autorange mode from a voltage range, the first reading in autorange is not valid.

3-36. Manual Trigger.

3-37. Manual triggering is available on all instruments. When the Sample Rate control is set to Hold, one measurement results each time the Manual pushbutton is depressed. If the pushbutton is depressed while the instrument is not in the Hold condition, automatic sampling will stop until the button is released.

3-38. SELF-TEST OPERATION.

3-39. The Internal Test function of the 3490A verifies proper operation of most of the dc circuits, logic circuits, and the ohmmeter reference. Use the following procedure to perform the Internal Tests. If Test No. 1 is not correct, refer to the Troubleshooting section. If any of the other tests are not correct, refer to the Performance Checks.

a. Set Function to TEST. If instrument has Ratio or Sample/Hold options, set RATIO to INT REF and SAMPLE/HOLD to OFF.

b. Set SAMPLE RATE control one position clockwise from HOLD.

c. Select RANGE 1, which is Logic Test. The display should follow the sequence below, starting at any point in the list. All readings should be in the order shown, with the polarity sign, numbers, and decimal points as shown. The last reading listed displays all digits as the count accumulates, then stops at the number shown. The last two digits in the last number are not significant to the test. If these displays are correct, most of the logic circuits are operating correctly.

+ 080.024
+ 04.0024
+ 0.20024
+ .010024
+ 0.09032
+ 10.0024
+ 200.024
+ 4000.24
+ 80002.4
+ 6000.xx OL

d. Select RANGE 2. The display should be .000000 2 counts. This verifies the 10 V range zero.

e. Select RANGE 3. Difference between + and - readings should be < 8 counts.

f. Select RANGE 4. Using a dc standard having an accuracy of $\pm 0.01\%$ or better, apply an input of -10.0000 V. Display should be +09.9990 \pm (16 counts + dc standard error). This checks the + Reference. If the 3490A has the ratio option, set RATIO to EXT REF 10 V and short EXT REF input terminals. Display should be ± 00.0000 . This checks the Ratio Reference Amplifier zero. Return RATIO switch to INT REF position and remove short from input.

g. Select RANGE 5. Display should be 000.000 \pm 15 counts, verifying the 0.1 V range zero.

h. Select RANGE 6. Using a dc standard having an accuracy of $\pm 0.01\%$ or better, apply an input of -10.0000 V. Display should be -1000.00 \pm (35 counts + dc standard error). This checks the dc input 0.01 attenuation and the dc amplifier x100 gain.

i. Select RANGE 7. Short Ω SIGNAL terminals. Display should be -09700.0 \pm 7000 counts. This verifies proper operation of the Ohms Converter.

3-40. DC VOLTAGE MEASUREMENTS.

3-41. For optimum accuracy of measurements on the .1 V range, first short the input terminals with a copper

bar or a large solid copper wire, and adjust A1R429 (Thermal Adj) for zero display. A1R429 is accessible through the rear panel. If the 3490A has the rear input connector, loosen the hinged cover to gain access to A1R429.

CAUTION

Be sure to connect the Guard Terminal and to observe the maximum voltage limitations noted on the front panel and in Table 3-1, or damage to the instrument may result.

3-42. DC Sample Rate and Response Time.

3-43. The sample rate and response time for dc voltage measurements are shown in Table 3-2.

Table 3-2. Sample Rate and Response Time.

Function	Minimum Sample Period*		Response Time
	Option 050	Option 060	
DC Volts	240.2 ms + 5 ms	200.1 ms + 4 ms	200.1 ms
AC Volts	1.26 s + .025 s	1.05 s + .025 s	1.05 s
Ohms			
.1 k thru			
100 k Ω	240.2 ms + 5 ms	200.1 ms + 4 ms	200.1 ms
1,000 k Ω	300.2 ms + 6 ms	250.1 ms + 5 ms	250.1 ms
10,000 k Ω	660.3 ms + 12 ms	550.2 ms + 10 ms	550.2 ms

*Sample Rate Control set to FAST position and instrument not in overload. Each counterclockwise step adds 240 ms in Option 050 instruments, 200 ms in Option 060 instruments.

3-44. Input Resistance.

3-45. Input resistance in the dc function is greater than 10^{10} ohms on the .1 V, 1 V, and 10 V ranges, and 10 megohms \pm 0.15 % on the 100 V and 1000 V ranges.

3-46. AC VOLTAGE MEASUREMENTS.

CAUTION

Be sure to connect the Guard Terminal and to observe the maximum voltage limitations noted on the front panel and in Table 3-1, or damage to the instrument may result, and high frequency measurements will be in error.

3-47. The display will NOT read zero on any ac range with the input shorted. The indication on all ranges with the input shorted should be less than 50 counts. The accuracy of ac measurements below 1.0% of full range is not specified.

3-48. AC Sample Rate and Response Time.

3-49. The sample rate and response time for ac voltage measurements are shown in Table 3-2.

3-50. Frequency Range.

3-51. Frequency range of the ac converter is 20 Hz to 250 kHz, with a maximum volt-Hertz product of 10^7 . That is, the frequency range for the 1 V and 10 V ranges is 20 Hz to 250 kHz, but the maximum frequency at 100 V is 100 kHz, and at 1000 V it is 10 kHz.

3-52. Input Impedance.

3-53. Input impedance in the ac function is the same on all ranges, and is $2\text{ M}\Omega \pm 1\%$ in parallel with $< 65\text{ pF}$ in instruments without rear panel input and $< 90\text{ pF}$ in instruments having the rear panel input connector.

3-54. Harmonic Distortion.

3-55. The 3490A has an average-responding ac-dc converter circuit calibrated to display the rms value of a sinusoidal input. Therefore, any distortion present in the input signal will affect the accuracy of the measurements as shown in Table 3-3.

Table 3-3. Distortion Error.

Harmonic	% Distortion	% Error (*Fundamental)	
		Max. Positive	Max. Negative
Any even	0.1	0.000	
	0.5	0.001	
	1.0	0.005	
	2.0	0.020	
Third	0.1	0.033	0.003
	0.5	0.168	0.167
	1.0	0.338	0.328
	2.0	0.687	0.667
Fifth	0.1	0.020	0.020
	0.5	0.101	0.099
	1.0	0.205	0.195
	2.0	0.420	1.380

*Depends on phase relationship between harmonic and fundamental.

3-56. RESISTANCE MEASUREMENTS.

3-57. When the 3490A is making resistance measurements, movement of the instruction card will cause display readings to jump. For optimum accuracy of measurements on the .1 k Ω range, first set Range and Function to .1 V dc, short the input terminals with a copper bar or large solid copper wire, and adjust A1R429 (Thermal Adj) for zero display. A1R429 is accessible through the rear panel. If the 3490A has the rear input connector, loosen the hinged cover to gain access to the adjustment.

CAUTION

Be sure to connect the Guard Terminal and to observe the maximum voltage limitations noted on the front panel and in Table 3-1, or damage to the instrument may result.

3-58. Input Connections.

3-59. Figure 3-3 shows the proper connections for making resistance measurements. All four terminals must be connected, since there is no internal connection between Ω Signal Low and Input Low. Maximum total Ω Signal lead resistance permissible is 10 Ω .

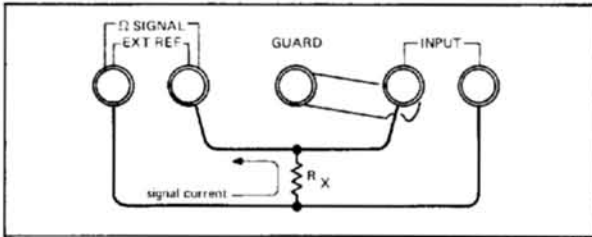

Figure 3-3. Ohmmeter Input Connections.

3-60. Ohms Signal Voltage and Current.

3-61. The maximum voltage across the resistance being measured is 13 V for valid measurements and 25 V in overload. Table 3-4 lists the approximate short circuit current for each range. Accurate voltage and current sources are not required, since a resistance measurement is the ratio of the voltage across the unknown resistance as a result of the reference current, to the reference voltage which determines the amount of the current.

Table 3-4. Ohmmeter Current.

Range	Nominal Current
.1 k Ω	1 mA
1 k Ω	1 mA
10 k Ω	1 mA
100 k Ω	10 μ A
1,000 k Ω	10 μ A
10,000 k Ω	1 μ A

3-62. Ohmmeter Sample Rate and Response Time.

3-63. Ohmmeter sample rates and response times are shown in Table 3-2.

3-64. EXTERNAL TRIGGER (Option 020).

3-65. The BCD/Remote Expand Option 020 adds the capability of remotely triggering the 3490A through either the Data Output or Remote Input connector. In order to remotely trigger the instrument, the Sample

Rate control must be set to Hold, or a continuous Low signal applied to the Hold connection at either rear panel connector. The External Encode signal logic levels and timing requirements are shown in Figure 3-4. The High to Low transition of External Encode and Data Flag can occur simultaneously.

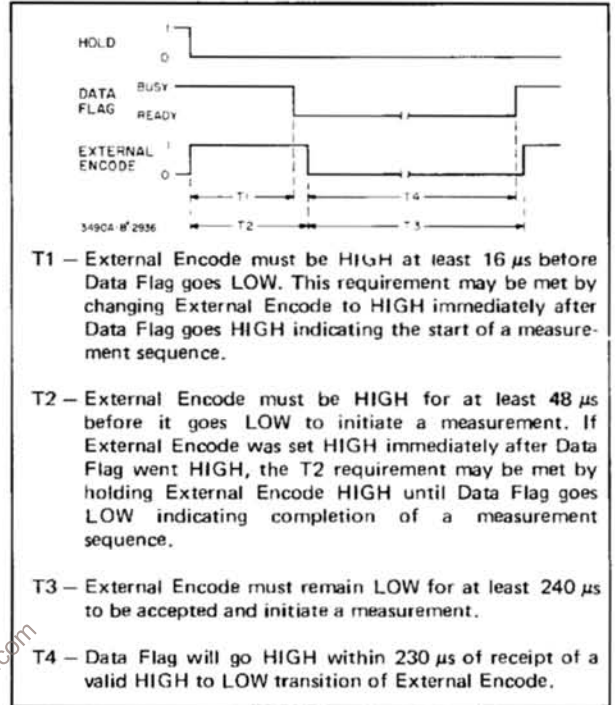

- T1 — External Encode must be HIGH at least 16 μ s before Data Flag goes LOW. This requirement may be met by changing External Encode to HIGH immediately after Data Flag goes HIGH indicating the start of a measurement sequence.
- T2 — External Encode must be HIGH for at least 48 μ s before it goes LOW to initiate a measurement. If External Encode was set HIGH immediately after Data Flag went HIGH, the T2 requirement may be met by holding External Encode HIGH until Data Flag goes LOW indicating completion of a measurement sequence.
- T3 — External Encode must remain LOW for at least 240 μ s to be accepted and initiate a measurement.
- T4 — Data Flag will go HIGH within 230 μ s of receipt of a valid HIGH to LOW transition of External Encode.

Figure 3-4. External Trigger Sequence (Option 020).

3-66. DATA OUTPUT (Option 021).

3-67. The Data Output option provides ten columns of measurement data, including polarity, range, function, and overload information. A Data Flag (Print Command) output is also provided, as are inputs for printer hold and triggering. Figure 2-5 shows the Data Output connector and signals. A mating connector, -hp- Part No. 1251-0086 (Amphenol No. 57-30500-375) is supplied with Option 021. A cable terminated at each end by a 50-pin connector, -hp- 562A-16C, is available for connection to -hp- digital recorders.

3-68. Output Signals and Levels.

3-69. If the Model 3490A is equipped with Data Output Option 021, ten columns of 1-2-4-8 coded BCD information are provided. In addition to 6 columns of measurement magnitude information, range, function, polarity, and overload information are provided. The logic HIGH level = +3.9 V \pm 1.5 V, 400 μ A max. The LOW level = 0.3 V \pm 0.3 V, 15 mA max. Columns 1 through 6 print the numerical magnitude of a measurement. Figure 2-5 shows the print code for columns 7 through 10, using a standard -hp- print wheel, + or - 1248. The HIGH/LOW switch on the Outguard Data Output Assembly, A10, must be set to correspond to the logic true level required by the digital recorder used. Figure 3-5 shows the printout for Option 021.

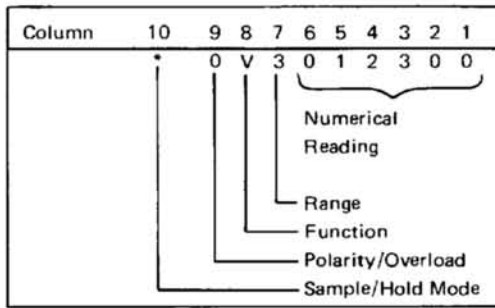

Figure 3-5. Option 021 Printout.

3-70. The Data Flag (Print Command) output signal changes from LOW to HIGH at the beginning of a measurement, and returns to LOW at the completion of a reading cycle. If the instrument is operating in the autorange mode, Data Flag remains HIGH until after one reading has been completed on the correct range. The HIGH to LOW transition constitutes a Print Command signal to a digital recorder.

3-71. Input Signals and Levels.

3-72. Three input connections are available at the Data Output connector. The input logic HIGH = +3.9 V \pm 1.5 V, 100 μ A max, or an open circuit. The LOW level = +0.3 V \pm 0.3 V, 2 mA max, or contact closure to ground through <300 Ω . A HIGH input at the Printer Hold connection causes the 3490A to stop automatic sampling until the line returns to LOW. A continuous LOW connection at the Hold input prevents automatic sampling and permits external triggering. When Hold is LOW, a LOW input level at the External Encode input for a minimum of 240 μ s initiates one reading cycle (see Paragraph 3-64).

3-73. Data Output Isolation.

3-74. All output and input lines at the Data Output connector are isolated from the internal (inguard) circuits and from the input terminals. The instrument will maintain all normal- and common-mode rejection characteristics with the Data Output lines properly connected. Outguard ground is isolated from inguard common and from chassis (power line) ground and may be floated up to 40 V above chassis.

3-75. REMOTE CONTROL (Option 022).

3-76. In addition to remote control of range and function, the Remote Control option includes provision for external triggering. A Program Flag output is HIGH during remote program execution, and the Data Flag output is HIGH during a measurement sequence. A mating connector, -hp- Part No. 1251-0084 (Amphenol No. 57-30360-375) is supplied with the Remote Control option.

3-77. Input Signal Requirements.

3-78. The Remote Control option permits remote selection of the remote mode of operation, and remote programming of range and function, including Test and optional Sample/Hold. For input signals, the logic HIGH level = +3.9 V \pm 1.5 V, 100 μ A max., or an open circuit. The LOW level = +0.3 V \pm 0.3 V, 2 mA max., or contact closure to ground through <300 Ω . Figure 2-6 shows the binary coding required for range and function programming, as well as the requirements for the other input signals.

3-79. Output Signals.

3-80. The Program Flag output changes from LOW to HIGH at the beginning of outguard-to-inguard transfer of program information, and returns to LOW to indicate the transfer is complete and the instrument is ready for a measurement. The Data Flag output changes from LOW to HIGH at the beginning of a measurement, and returns to LOW at the completion of a reading cycle. If the instrument is operating in the autorange mode, Data Flag remains at HIGH until one reading has been completed on the correct range. The logic levels for output signals are as follows: HIGH = +3.9 V \pm 1.5 V, 400 μ A max; LOW = +0.3 V \pm 0.3 V, 15 mA max.

3-81. Remote Programming Procedure.

3-82. All program input lines are HIGH unless forced LOW by an external connection. The Remote Enable line must be held LOW continuously. If it returns to HIGH, range and function program capability reverts to the front panel controls. The remote program sequence is shown in Figure 3-6.

3-83. Remote Control of Test Function.

3-84. The Test function may be selected remotely by programming Function A and B HIGH. Test No. 1, Logic Test, is selected by programming the Autorange line HIGH. Tests No. 2 through 7 are selected by programming Range lines A, B and C as indicated in Figure 2-6. When Test No. 1 is selected, a minimum of 10 readings must be taken to record all the test data before changing the program. In Test No. 3, a minimum of two readings is required to record the turnover error test. For all other tests, only one reading is necessary. Paragraph 3-38 describes the internal tests. The -10 V input required for Test No. 6, and the Ω signal short required for Test No. 7 may be applied throughout the test sequence without affecting the other tests. In Test No. 4, the ratio reference check cannot be controlled remotely.

3-85. Remote Control Isolation.

3-86. All input and output lines at the Remote Input connector are isolated from the internal (inguard) circuits and from the input terminals. The instrument

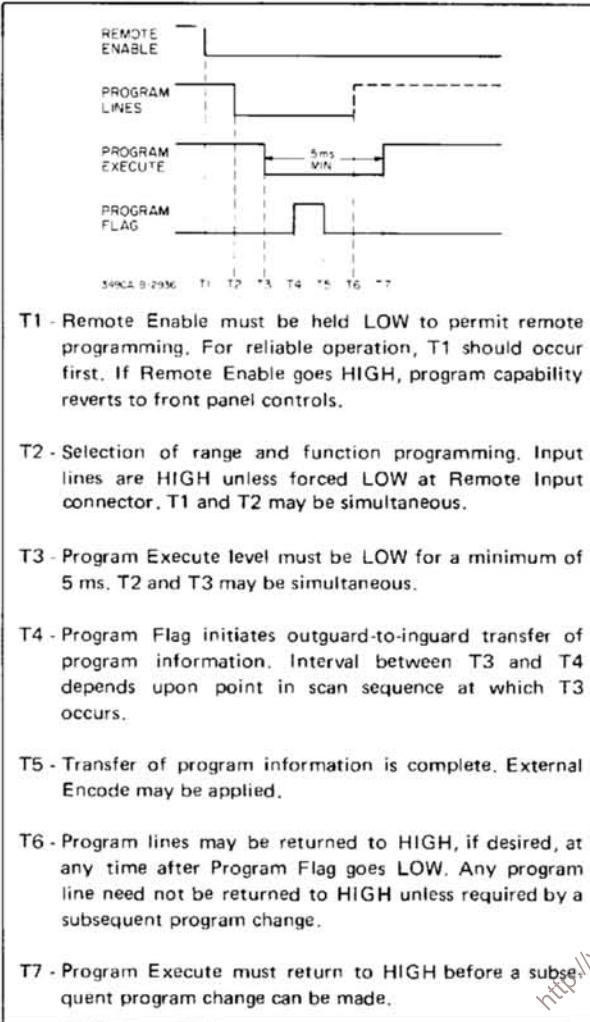

- T1 - Remote Enable must be held LOW to permit remote programming. For reliable operation, T1 should occur first. If Remote Enable goes HIGH, program capability reverts to front panel controls.
- T2 - Selection of range and function programming. Input lines are HIGH unless forced LOW at Remote Input connector. T1 and T2 may be simultaneous.
- T3 - Program Execute level must be LOW for a minimum of 5 ms. T2 and T3 may be simultaneous.
- T4 - Program Flag initiates outguard-to-inguard transfer of program information. Interval between T3 and T4 depends upon point in scan sequence at which T3 occurs.
- T5 - Transfer of program information is complete. External Encode may be applied.
- T6 - Program lines may be returned to HIGH, if desired, at any time after Program Flag goes LOW. Any program line need not be returned to HIGH unless required by a subsequent program change.
- T7 - Program Execute must return to HIGH before a subsequent program change can be made.

Figure 3-6. Remote Program Sequence (Option 022).

will maintain all normal- and common-mode rejection characteristics with the Remote Control lines properly connected. Outguard ground is isolated from inguard common and from chassis (power line) ground and may be floated up to 40 V above chassis.

3-87. HEWLETT-PACKARD INTERFACE BUS I/O (Option 030).

NOTE

Read Paragraphs 3-107 and 3-134 through 3-138 before writing programs for the 3490A.

3-88. The Hewlett-Packard Interface Bus I/O option for the Model 3490A Digital Voltmeter allows the instrument to be controlled remotely and to output measurement information to a digital recorder. It permits remote programming of range, function, Trigger mode, and Sample/Hold mode. Neither the power line switch nor the Ratio mode can be programmed remotely. The output data includes measurement status, function,

polarity, magnitude, and range, in the format given in Paragraph 3-126. Several instruments may be connected in parallel to the same bus and controlled by a single controlling instrument. Controlling instruments that may be used with the 3490A HP-IB option include the -hp- 9800 series calculators and the -hp- Model 3260A Marked Card Programmer.

3-89. The operating instructions contained in this section include address codes and address code selection, program codes, output format, and timing sequence information. The HP-IB system uses the ASCII (American Standard Code for Information Interchange) eight-bit octal code in a parallel bit, serial character form.

3-90. HP-IB Signals.

3-91. For convenience and brevity, each bus signal line is identified by a mnemonic, which is an abbreviation of the signal name. Table 3-5 lists the signals used on the HP-IB.

NOTE

The Hewlett-Packard Interface Bus uses LOW true logic.

Table 3-5. HP-IB Signal Mnemonics.

Mnemonic	Signal Name
NDAC	Data Not Accepted
DAV	Data Valid
DIO (1-8)	Data Input/Output
IFC	Interface Clear
ATN	Attention
REN	Remote Enable
NRFD	Not Ready For Data
SRQ	Service Request

3-92. **Data Lines DIO1 through DIO8.** All eight Data Input/Output lines are LOW true. In the 3490A, DIO8 is always HIGH, or false.

3-93. **Attention, ATN.** When the Attention line is LOW, all units connected to the bus must respond to the controller and interpret the data on lines DIO1 through DIO7 as an address or command. When ATN is HIGH, only the unit which has been addressed as the talker and the unit (or units) addressed as listener(s) may and are required to respond on the DAV, NDAC, and NRFD lines.

3-94. **Handshake Signals.** Three lines are used for what is called a "Handshaking" technique. The listener (or listeners) set NRFD to HIGH to indicate readiness to accept data. The NRFD line is wire OR'd to all units on the bus so that data will not be transmitted until the slowest listener on the bus signals that it is ready for data. When all listeners are ready (NRFD goes HIGH), the talker puts the first character on the data lines,

DIO1-8. When the data is valid, the talker sets DAV to LOW. As each listener receives and has completed processing this data, it allows its NDAC output to go HIGH. This line is also wire OR'd to each unit, and the line does not actually go HIGH until all listeners have accepted the data. The talker may not change the data on DIO1-8 until NDAC goes HIGH.

3-95. NRFD. Each listener may set NRFD HIGH as soon as it has completed and acknowledged acceptance of the previous data. This signals to the talker that it may transmit new data on the data lines DIO1-8.

3-96. DAV. After the talker places data on the data lines, it must set DAV LOW to indicate that the data is valid. A listener may not process data until DAV goes LOW. DAV cannot be set HIGH again until NDAC goes HIGH, indicating that all listeners have finished processing the data.

3-97. NDAC. When all listeners have accepted data, NDAC goes HIGH, indicating to the talker that the data is no longer needed. A listener may set NRFD to HIGH at the same time or at any time after NDAC goes LOW, to indicate that it is ready for new data.

3-98. SRQ. Any unit on the bus having service request capability may set SRQ LOW at any time. This indicates that a unit wants the attention of the controller. The controller may then check each unit on the bus individually to see which unit or units pulled SRQ LOW, or it may ignore the service request. SRQ does not hinder other normal operations on the bus.

3-99. IFC. When the controller sets the Interface Clear line LOW, all units immediately stop driving DIO1-8, ATN, DAV, NRFD, and NDAC. When IFC is HIGH, all units may operate according to the normal bus rules.

3-100. REN. All instruments on the bus are enabled to respond to remote programming data if the controller holds the REN line LOW. The 3490A may be set to remote operation by setting REN LOW and sending its listen address. It may be returned to local (front panel) control by setting REN HIGH. An exception is noted in Paragraph 3-107. Normally, all units on the bus respond to their front panel controls when REN is HIGH.

3-101. Talk Only (No Controller).

3-102. The 3490A with the HP-IB option may be used to provide data to a printer without having a controller on the bus. The printer must be able to accept the ASCII data information to handshake with the 3490A on the NRFD, DAV, and NDAC lines. The slide switch on the 3490A rear panel must be set to the TALK ONLY position (see Figure 3-1). The instrument is then controlled by the front panel controls for selection of function, range, Sample/Hold, and Trigger mode. The 3490A may be triggered through the rear panel Trigger Connector, J11, or allowed to sample at a rate selected by the SAMPLE RATE control. *When a controller is connected to the bus, the rear panel switch must be set to the ADDRESSABLE position.*

3-103. HP-IB Control of 3490A.

3-104. Listen and Talk Addresses. The 3490A may be addressed to listen or to talk by setting ATN LOW and sending the proper listen or talk address. Each 3490A HP-IB I/O is normally programmed at the factory for a listen address of 6 and a talk address of V. If two or more instruments are to be operated on the same bus, they should not have the same address. Table 3-6 lists the address codes possible. Address is selected by positioning jumper wires in a header on the Outguard Mother Board Assembly A31, shown in Figure 3-7. Remove the top cover to gain access to this header. Note that only five binary bits of the 7-bit format are selectable. These five bits are the same for both the listen and talk addresses. The sixth and seventh bits are provided by the controller to determine whether the address is a talk or listen address: 01 for listen, 10 for talk. Absence of a jumper is a logical "1"; presence of a jumper is a logical "0". At least one jumper must always be installed, because the 11111 address is not allowed. This code is used to unaddress the instrument to talk or listen.

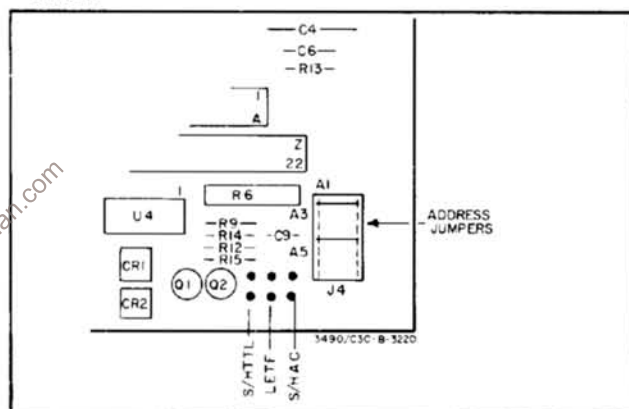

Figure 3-7. Position of Jumper Wires on Outguard Mother Board Assembly A31.

3-105. Addressed to Listen. When the 3490A is first turned on, the HP-IB programming circuits will conform to the front panel control settings. It must be placed in remote control before programming.

3-106. Remote Control. To place the 3490A in remote control, set ATN and REN to LOW and transmit the 3490A listen code. REN must be held LOW continuously to maintain remote control. When the instrument is first set to remote control, the HP-IB circuits store the front panel range and function selections. Sample/Hold mode is Off (S0), Trigger is set to Internal Sample Rate (T0), and Mode of Operation is Addressed Multiple with No Output (M0). Any changes in this programming must then be made by remote control. ATN must be set HIGH and the remote programming data transmitted. The 3490A will accept only the alpha identifiers E, F, M, R, S and T, and digits 0 through 7. Table 3-7 lists the 3490A program codes. The 3490A may be unaddressed to listen, by sending the character ?. Figure 3-8 is a timing diagram for data and handshake lines when the 3490A is addressed to listen.

Table 3-6. Address Codes.

ASCII CODE CHARACTER		BINARY CODE							OCTAL CODE	
Listen Address	Talk Address	Jumper →		A5	A4	A3	A2	A1	Listen	Talk
		b ₇	b ₆	b ₅	b ₄	b ₃	b ₂	b ₁		
SP	@			0	0	0	0	0	040	100
!	A		See	0	0	0	0	1	041	101
"	B		note	0	0	0	1	0	042	102
#	C		below	0	0	0	1	1	043	103
\$	D			0	0	1	0	0	044	104
%	E			0	0	1	0	1	045	105
&	F			0	0	1	1	0	046	106
'	G			0	0	1	1	1	047	107
(H			0	1	0	0	0	050	110
)	I			0	1	0	0	1	051	111
*	J			0	1	0	1	0	052	112
+	K			0	1	0	1	1	053	113
,	L			0	1	1	0	0	054	114
-	M			0	1	1	0	1	055	115
.	N			0	1	1	1	0	056	116
/	O			0	1	1	1	1	057	117
0	P			1	0	0	0	0	060	120
1	Q			1	0	0	0	1	061	121
2	R			1	0	0	1	0	062	122
3	S			1	0	0	1	1	063	123
4	T			1	0	1	0	0	064	124
5	U			1	0	1	0	1	065	125
6	V			1	0	1	1	0	066	126
7	W			1	0	1	1	1	067	127
8	X			1	1	0	0	0	070	130
9	Y			1	1	0	0	1	071	131
:	Z			1	1	0	1	0	072	132
;	[1	1	0	1	1	073	133
<	\			1	1	1	0	0	074	134
=]			1	1	1	1	1	075	135
>	~			1	1	1	1	0	076	136

Note: Only first five bits of binary code are given, and these bits are the same for both listen and talk addresses. Sixth and seventh bits determine whether address is listen (01) or talk (10).

3-107. Return to Local Control. The 3490A may be returned to local control by setting REN HIGH. However, it cannot be returned to local during output of a reading. If REN goes HIGH then LOW again while a reading output is in progress, the 3490A will stay in remote. In order to return to local, then, REN must be HIGH when no reading output is in progress. The 3490A may also be returned to local by turning its power off and back on again.

NOTE

If the 3490A is returned to local by setting REN HIGH, but is not unaddressed to talk, it will continue to output readings. If there is a listener such as a 9800 series calculator on the bus that is addressed to listen but is not able to receive data, the 3490A will stop sampling, since it cannot output data. This condition may appear to be a failure, since the 3490A would typically be expected to continue sampling and no longer be under program control.

3-108. Remote Program Sequence. The order of remote programming is not important except that it must end with the E command to execute the program. The normal programming sequence is one alpha identifier followed by one digit. For example, the program F2R4SIT2MIE selects AC volts, 10 V range, Sample/ Hold off, Next External Trigger, Addressed Multi with Output (see Table 3-7). If it is necessary to change only the range, for example, the next program instruction might be R3E. In other words, program data will remain stored as long as the instrument is in remote control, unless changed by a subsequent programming data. If more than one alpha identifier or digit is sent, the last valid identifier or digit will be stored. For example, FR1ST20SMF3E will be accepted as R5T0F3E. Paragraph 3-131 gives a programming example using the -hp-9820A Calculator as the controller and printer. The power line switch cannot be programmed.

3-109. Trigger Source Program. The following paragraphs explain the trigger source codes shown in Table 3-7.

3-110. T0, Internal Sample Rate. The 3490A releases the Hold line when ready for a new measurement to be

Table 3-7. Program Codes.

CHARACTER	USE	OCTAL CODE	BINARY CODE						
			b ₇	b ₆	b ₅	b ₄	b ₃	b ₂	b ₁
R	Range Program Identifier	122	1	0	1	0	0	1	0
1	10,000 k Ω ; Test 7	061	0	1	1	0	0	0	1
2	1,000 k Ω ; 1000 V; Test 6	062	0	1	1	0	0	1	0
3	100 k Ω ; 100 V; Test 5	063	0	1	1	0	0	1	1
4	10 k Ω ; 10 V; Test 4	064	0	1	1	0	1	0	0
5	1 k Ω ; 1 V; Test 3	065	0	1	1	0	1	0	1
6	.1 k Ω ; .1 V; Test 2	066	0	1	1	0	1	1	0
7	Autorange; Test 1	067	0	1	1	0	1	1	1
F	Function Program Identifier	106	1	0	0	0	1	1	0
0	DC Volts	060	0	1	1	0	0	0	0
1	K Ohms	061	0	1	1	0	0	0	1
2	AC Volts	062	0	1	1	0	0	1	0
3	Test	063	0	1	1	0	0	1	1
S	Sample/Hold Program Identifier	123	1	0	1	0	0	1	1
0	Sample/Hold Off	060	0	1	1	0	0	0	0
1	Sample/Hold Off	061	0	1	1	0	0	0	1
2	Track/Hold	062	0	1	1	0	0	1	0
3	Acquire/Hold	063	0	1	1	0	0	1	1
T	Trigger Source Program Identifier	124	1	0	1	0	1	0	0
0	Internal Sample Rate *	060	0	1	1	0	0	0	0
1	Immediate Internal	061	0	1	1	0	0	0	1
2	Next External Trigger	062	0	1	1	0	0	1	0
3	None	063	0	1	1	0	0	1	1
M	Mode of Operation Program Identifier	115	1	0	0	1	1	0	1
0	Addressed Multi with No Output	060	0	1	1	0	0	0	0
1	Addressed Multi with Output	061	0	1	1	0	0	0	1
2	Addressed Single with No Output	062	0	1	1	0	0	1	0
3	Addressed Single with Output	063	0	1	1	0	0	1	1
4	Interrupt Multi with No Output	064	0	1	1	0	1	0	0
5	Interrupt Multi with Output	065	0	1	1	0	1	0	1
6	Interrupt Single with No Output	066	0	1	1	0	1	1	0
7	Interrupt Single with Output	067	0	1	1	0	1	1	1
E	Execute Mode of Operation Program	105	1	0	0	0	1	0	1

* If Internal Sample Rate is programmed, make sure front panel Sample Rate control is set to desired position.

taken, and the instrument is triggered according to the internal sample rate. If the front panel Sample Rate control is set to the Hold position, it will not sample until the manual pushbutton is pushed, an external trigger occurs, or the front panel control is taken out of hold.

3-111. T1, Immediate Internal. The 3490A never releases the Hold line, but instead provides an External Encode command when ready for a new measurement to begin. It is, therefore, sampling at its maximum rate, and the front panel Sample Rate control is bypassed.

3-112. T2, Next External Trigger. The 3490A keeps the Hold line LOW and releases the Sample/Hold Inhibit line when ready to accept the next trigger. When an external trigger occurs, the HP-IB I/O issues the External Encode command. Pushing the front panel manual trigger pushbutton will also initiate a reading.

3-113. T3, None. The 3490A keeps the Hold line LOW and checks for an output request. This method may be used to store data for output at a later time.

3-114. Mode of Operation. The following paragraphs explain the mode of operation codes shown in Table 3-7.

3-115. M0, Addressed Multiple with No Output. In this mode, operation is similar to operation when in local control and not addressed to talk. Readings are taken according to the programmed trigger, but no output occurs.

3-116. M1, Addressed Multiple with Output. The instrument will take a reading when triggered and output the reading if addressed to talk. If not addressed to talk, it will wait for its talk address to output data or its listen address to be programmed. After output of the data or receipt of new programming data, the HP-IB I/O returns to the beginning of the program to determine the trigger for the next reading.

3-117. M2, Addressed Single with No Output. The instrument takes one reading when triggered and does

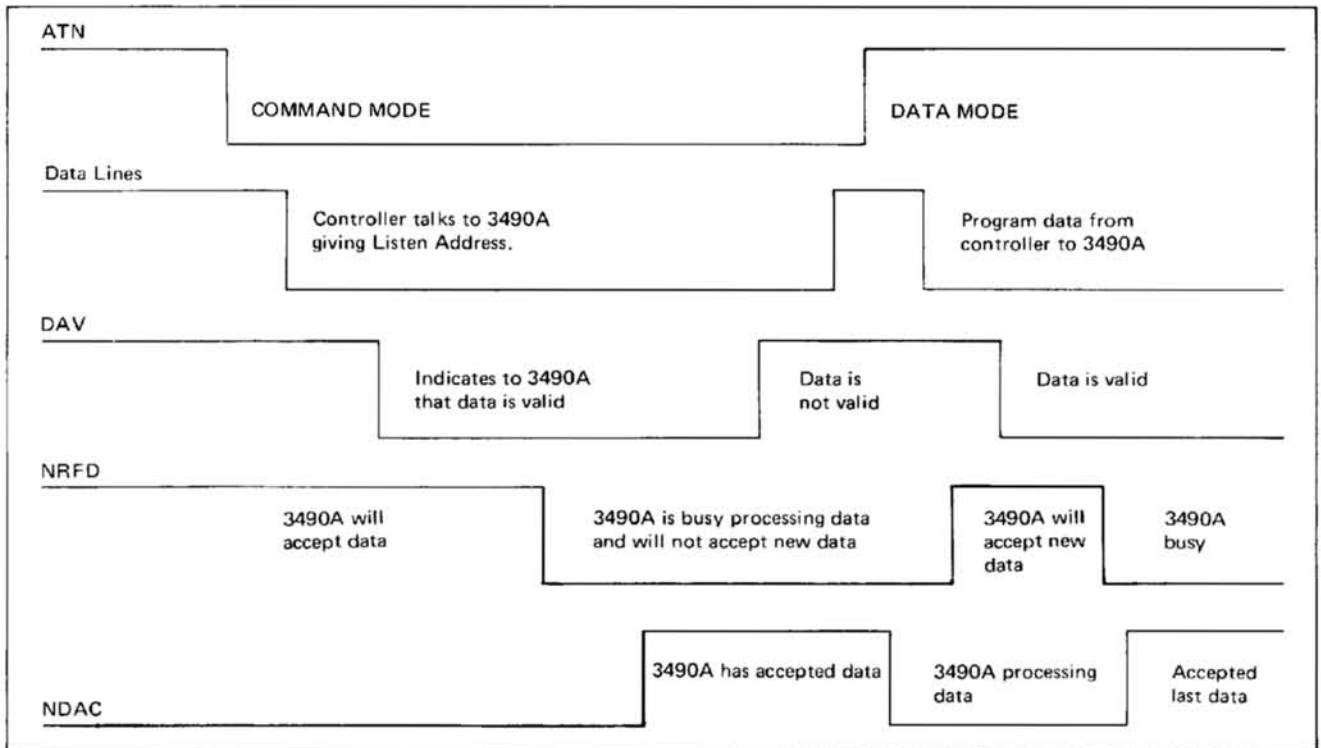

Figure 3-8. Timing Diagram, 3490A Addressed to Listen.

not output the reading. A new reading is initiated by reprogramming the 3490A or by going to local control.

3-118. M3, Addressed Single with Output. The instrument takes one reading when triggered and outputs the reading if addressed to talk. If not addressed to talk, it waits for its talk address to output or its listen address to be reprogrammed. After output of the reading data, a new reading is initiated by reprogramming the 3490A or by going to local control. If reprogramming occurs before output of the reading data, a new reading will be taken according to the new programming data.

3-119. M4, Interrupt Multiple with No Output. Programming of No Output overrides that of Interrupt, so this mode is the same as M0.

3-120. M5, Interrupt Multiple with Output. This mode is the same as M1 except that if the 3490A is not addressed to talk, it will pull the Service Request (SRQ) line LOW after each reading is taken. This line is taken HIGH when the reading is outputted or when new programming data is received. See Paragraph 3-116.

3-121. M6, Interrupt Single with No Output. Programming of No Output overrides that of Interrupt, so this mode is the same as M2.

3-122. M7, Interrupt Single with Output. This mode is the same as M3 except that if the 3490A is not addressed to talk, it will pull the Service Request (SRQ) line LOW after each reading is taken. This line is taken HIGH after output of the reading data or when new programming data is received. See Paragraph 3-116.

3-123. Repeating an Output. The 3490A can be made to output the same reading more than once. This can be accomplished by programming the 3490A with "M3E" and outputting the reading. Then reprogram the 3490A with "T3E". The 3490A can output the same reading as many times as desired. Programming with "T1E" initiates a new reading.

3-124. Addressed to Talk. The 3490A may be addressed to talk by setting ATN LOW and transmitting the 3490A talk address. It may be unaddressed to talk by addressing any other unit to talk, or by sending the character . Figure 3-9 is a timing diagram for data and handshake lines when a printer is addressed to listen and the 3490A is addressed to talk.

3-125. Output Control. Two general modes of output are possible, depending on the remote programming of the 3490A. If normal output (Addressed Multiple or Addressed Single, Table 3-7) is programmed, the 3490A will inhibit triggers after each reading and output data if already addressed to talk. If not addressed to talk, it will wait for its talk address before outputting data, or for its listen address to be reprogrammed. If Interrupt output is programmed and the 3490A is not addressed to talk, it will issue a Service Request after each reading and await recognition by the controller. If it is addressed to talk, it will inhibit triggers after each reading and proceed to output data.

3-126. Output Format. After the 3490A has been properly put into an output mode, the data will be

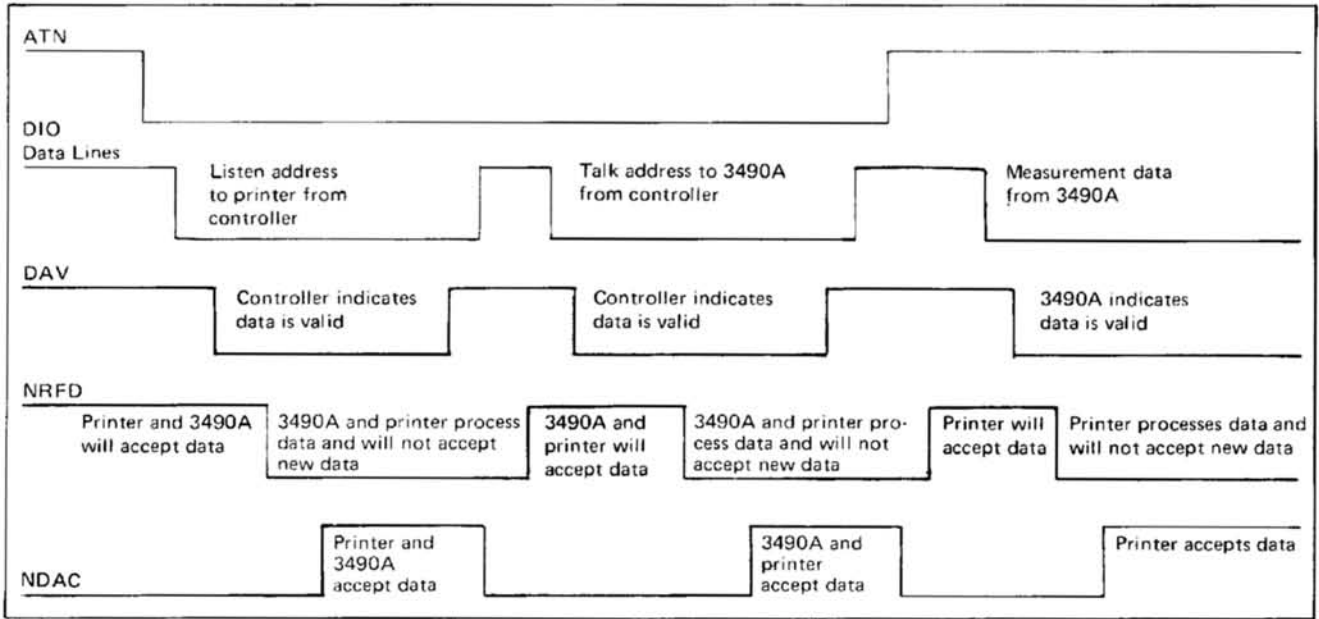

Figure 3-9. Timing Diagram, 3490A Addressed to Talk.

outputted in the following format: (Example listing: NDC+XXXXXXE-Y).

Status Code Alpha*

- N Normal Operation
- OL Overload
- R Ratio Mode
- S Sample/Hold Mode
- RS Ratio and Sample/Hold Mode

Function Code*

- AC AC Volts
- DC DC Volts
- KO Kilohms
- T Test

*Status and Function are two-character codes. If only one character is required, a blank space will be left so that the total output format will always be the same length.

Polarity

- + Positive Input or Positive Ratio
- Negative Input or Negative Ratio

Data

- XXXXXX Six digits, most significant digit first
- E Exponent Identifier
- Polarity of Exponent
- Y Exponent (Range Digit)
- CR Carriage Return
- LF Line Feed

3-127. Service Request. The 3490A is capable of requesting service on the bus and responding to serial polling for identification and status. If either mode of operation which specifies interrupt with output (M5 or M7) is programmed and 3490A is not programmed to talk, it will pull the Service Request (SRQ) line LOW after each reading.

3-128. For serial polling, the controller must pull the Attention (ATN) line LOW and send both the Status Poll Enable (SPE) command and the 3490A talk address. The SPE command is octal code 030, binary code 00 011 000. If the 3490A has pulled SRQ LOW, when it receives SPE and its talk address, it will transmit the ASCII character x1xxxxxx. The seventh bit being a "1" signifies that the 3490A did request service. The other bits do not convey any information concerning the status. After it receives the Status Poll Disable (SPD) command (octal code 031, binary code 00 011 001), the 3490A will output the data reading, since it is still addressed to talk. After outputting the data, it will return the Service Request line to HIGH. If it is unaddressed to talk before the SPD command is sent, it will keep the SRQ line LOW and wait for its talk address to output or its listen address to be reprogrammed. It will set SRQ HIGH if it is reprogrammed.

3-129. If the 3490A is in operating mode M5 or M7 and receives the SPE command and its talk address before a reading is completed, it will respond with the character x0xxxxxx. The seventh bit being a "0" indicates that it did not request service, and the other bits have no significance concerning status. This code (seventh bit "0") is also transmitted if the 3490A is in any of the other modes of operation (M0, M1, M2, M3, M4, or M6) and it receives the SPE command and its talk address.

3-130. If the 3490A has requested service and is addressed to talk but not sent the SPE command, it will not transmit a status code but will output the reading data if programmed for output (M1, M3, M5, or M7).

3-131. HP-IB Operating Example.

3-132. The following example uses a Hewlett-Packard Model 9820A as both controller and printer. The 9820A must be equipped with the 11144A Interface, and must have the Peripheral Control II ROM Block installed in the proper ROM block slot. An Interface Cable, -hp-10631A/B/C, is needed to connect the 3490A to the 9820A.

3-133. This program places the 3490A in remote control and programs the following:

Function	DC Volts
Range	10 V
Trigger	Immediate Internal
Mode	Addressed Single with Output

In the M3 Mode and T1 Trigger Source the 3490A provides an internal trigger to take one reading, and then it outputs this data. It is then instructed by the following program steps to take another reading, and this process is repeated until the stop button is pressed. If you do not wish to store this program in the calculator, substitute the EXECUTE key in place of STORE in the following sequence:



Initializes calculator.

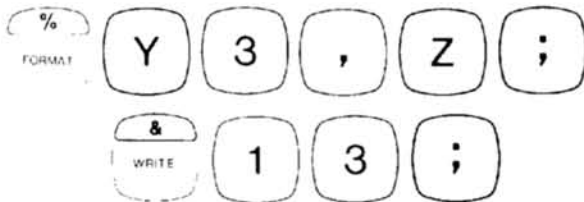

Sets REN LOW on bus.

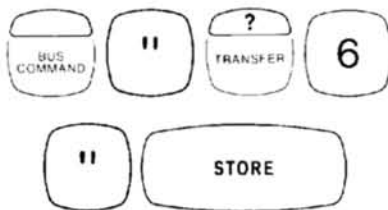

Addresses 3490A to listen. 3490A should go to remote control. REM annunciator should be ON.

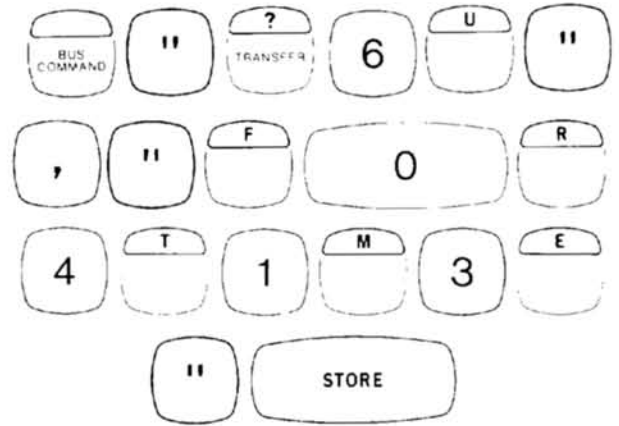

6 = 3490A listen address;

U = 9820A talk address.

This sequence programs 3490A to DC, 10 V range, Immediate Internal trigger, and Addressed Signal with Output.

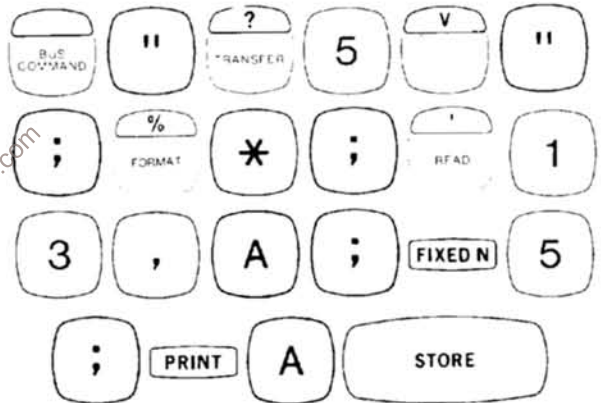

5 = 9820A listen address;

V = 3490A talk address.

Programs the 3490A to output data and programs 9820A to print.



Programs 3490A to take another reading and return to sequence 2 to output new data.



Ends calculator program.

To run this program, press



To halt program, press



To list program (print out stored program), press



NOTE

Read Paragraphs 3-107 and 3-134 through 3-138 before writing programs for the 3490A.

3-134. Special Trigger Programming Technique. When programming the 3490A, the E indicates the end of programming information and allows the 3490A to start operating according to the new programming instructions. The instructions are stored as they are received and do not require the E in order to be accepted. Because of this, one programming technique is to omit the E when the programming instructions are sent, and then transmit the E when it is desired that the 3490A make a reading. However, if the E is not sent with the programming instructions, the 3490A will take a reading either when ATN goes LOW or when an E is sent, whichever occurs first. Consequently, if the 3490A was programmed with "M3T1..." initially, and then the statement CMD "?U6","E" was used, the instrument would take two readings instead of one as programmed. There are two ways to prevent this:

a. After sending the programming instructions, don't change the listen and talk addresses until the E is sent. For example:

```
CMD "?U6", "F3R7M3T1"
.
.
CMD "E", "?5V"
```

b. First program the 3490A for no trigger, and then reprogram it for a trigger when a reading is to be made. For example:

```
CMD "?U6", "F3M3R7T3E" (The E is optional in this statement)
.
.
CMD "?U6", "T1E", "?5V"
```

3-135. Suppression of CR and LF. When outputting programming instructions from the 9800 series calculators without using the CMD statement, the Carriage Return (CR) and Line Feed (LF) normally output by the calculator must be suppressed. If not, they are seen as two programming characters by the 3490A. CR and LF may be suppressed in the 9820 by transmitting, Z at the end of the instructions. In the 9830, they may be suppressed by sending a semicolon.

9820 example:

```
CMD "?U6"; FMT "M3R7F0E"; Z; WRT 13
```

9830 example:

```
10 CMD "?U6"
20 OUTPUT (13, 30) "M3R7F0E";
30 FORMAT B
```

3-136. Invalid Programming Sequences.

3-137. The 3490A should not be programmed to an output mode (M1, M3, etc.), triggered and placed in local before being addressed to talk. A program which illustrates this invalid programming procedure is shown below. The 3490A is first placed in remote, then programmed to output (M3) and triggered (T1E). It is then placed in local and the program is repeated.

0: FMT Y3,Z;WRT 13	REMOTE
1: CMD "?U6","F0R4M3T1E"	OUTPUT MODE & TRIGGER
2: (Delay statement)	
3: FMT Y4,Z;WRT 13	LOCAL
4: (Delay statement)	
5: Go to 0	LOOP BACK
6: END	

The following statements validate the above program.

- Initially program a no-output mode (M0, M2) when the reading is not to be placed on the HP-IB: Substitute M2 for M3 in line 1 in the above program.
- "Untalk" the 3490A before going to local control: Insert CMD "?-?" before line 3 in the above program.
- Take reading before going to local: Add CMD "?5";FMT *;RED 13,A before line 3 of the above program.

3-138. If the 3490A is connected to the HP-IB and under local control, it will respond to its talk address and output data on the HP-IB. If the calculator is addressed to listen but not programmed to input readings, the situation described in Paragraph 3-107 will occur (see Paragraph 3-107).

3-139. Control by Marked Card Programmer.

3-140. The 3490A with Option 030 may be programmed by using a Marked Card Programmer such as

the -hp- Model 3260A or Model 9860A. An example of marked card programming is shown in Figure 3-10. The binary code shown in Table 3-7 is used in marking the card. Use a soft black pencil to mark each space representing a "1" in the code. The "200" space must be marked whenever the 3490A is addressed to listen or clear (unaddressed). The "200" bit pulls the ATN line LOW, and should be used only for addressing.

3-141. The following instructions must be observed for reliable programming.

1. The 3490A cannot receive programming data while it is making a reading. Therefore, if the 3490A is allowed to sample, programming instructions from the card reader will be ignored by the 3490A while it is making a reading. Two methods may be used to control sampling.

a. Before programming, set the 3490A Sample Rate control to the HOLD position. Do not program trigger mode. Instead, after programming is completed, change the Sample Rate control manually from the HOLD position to the desired sample rate. Then if a subsequent change in the 3490A program is necessary, the Sample Rate control must be set to the HOLD position again before programming.

b. Set the 3490A Sample Rate control to the HOLD position and program the 3490A for trigger mode T1, Immediate Internal Trigger. In this mode, the 3490A will continue to sample at the maximum rate, and the front panel control setting will have no effect. In order to reprogram the 3490A under these conditions, the 3490A Line switch should be turned OFF and back ON again. This returns the instrument to local (front panel) control.

2. The line on the marked card immediately following the last line in which ATN is pulled LOW ("200" space marked) should be left blank. This enables the 3490A to be in the programming routine before the first programming character is sent. If this line is not left blank, the character on that line will be ignored.

3-142. SAMPLE/HOLD MEASUREMENTS (Option 040 or 045).

3-143. Definition of Sample/Hold Terms.

3-144. Track/Hold. This term describes the mode of operation in which the "Hold" mode (see Paragraph 3-146) begins within 400 nanoseconds after receipt of a Sample/Hold Trigger command. Prior to this time, the Sample/Hold amplifiers follow, or track, the output of the 3490A DC Input Amplifier. Upon receipt of a Sample/Hold Trigger command, the amplifiers "hold" for measurement the voltage present on the Amplifier A integrating capacitor at that time. After the 3490A completes a measurement, the "track" mode resumes.

3-145. Acquire/Hold. This mode differs from the Track/Hold mode in that a precise delay is added in the Sample/Hold trigger path. This delay allows the DC Input and Sample/Hold amplifiers to respond to a full-range step input voltage before the Hold mode begins.

3-146. Hold Mode. Following a Sample/Hold Trigger command, the Sample/Hold Amplifiers A and B retain for measurement the voltage present at Amplifier A when the Hold command was received. During this retention period, the Sample/Hold amplifiers are said to be in the Hold mode. These amplifiers are also placed in the Hold mode during the run-down, or discharge, portion of the measurement cycle.

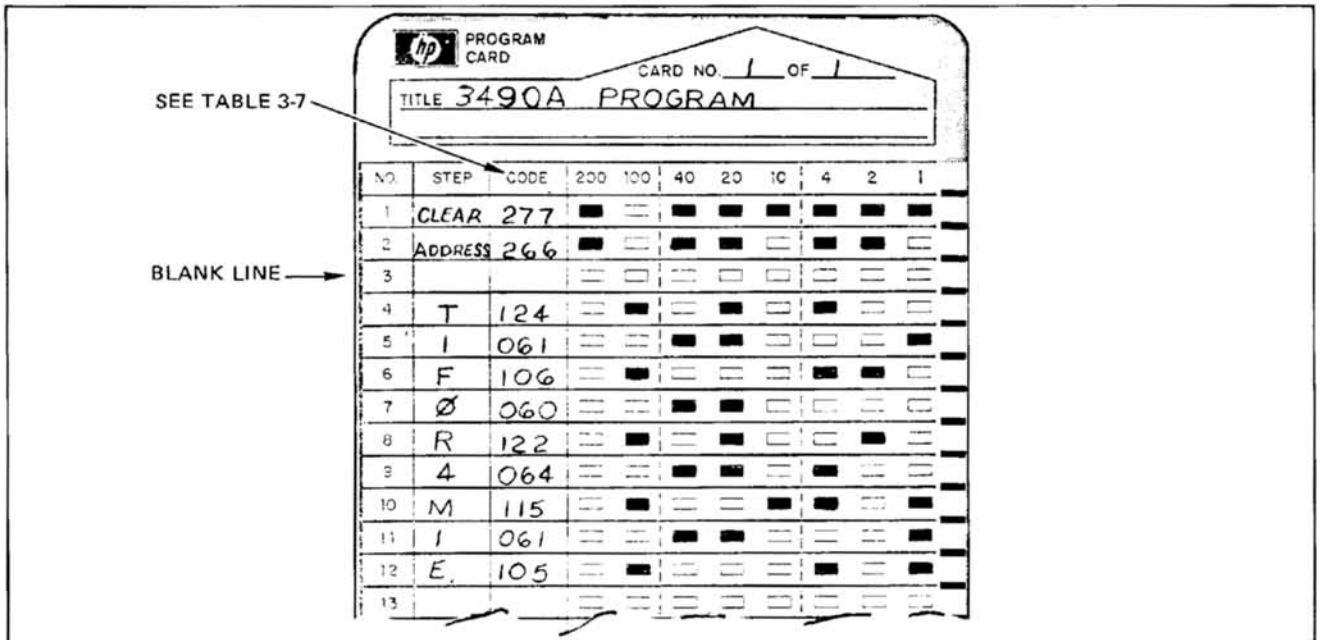

Figure 3-10. Example of Marked Card Programming.

3-147. Track Mode. After completion of a measurement, the Sample/Hold amplifiers follow, or track, the input voltage until they are placed in the Hold mode by a subsequent Sample/Hold Trigger command. This condition is referred to as the Track mode.

3-148. Aperture Time. This is defined as the period between receipt of a Sample/Hold Trigger command and the time at which the Sample/Hold switching circuits place Amplifier A in the Hold mode.

3-149. Maximum Acquisition Time. This is the time required for the DC Input and Sample/Hold amplifiers to respond to a full-range step input voltage.

3-150. Delay. This term, as used in connection with Acquire/Hold operation, refers to the delay added in the Sample/Hold trigger path which extends the aperture time to include the acquisition time.

3-151. Sample/Hold Trigger (TTL). This is the dc coupled command to the Sample/Hold circuits which initiates a Hold mode. The signal must go from HIGH to LOW for a minimum of 30 nanoseconds. It must go HIGH at least 600 microseconds prior to going LOW (see Figure 2-11). This command will initiate a 3490A measurement only under certain conditions (see Paragraph 3-168). The term "Sample/Hold Trigger" is used as a general term in this manual, referring either to a dc coupled or ac coupled trigger signal.

3-152. Sample/Hold AC Trigger. This ac coupled command has the same effect as the Sample/Hold Trigger command (TTL). This signal must be a negative-going pulse at least 30 nanoseconds wide with an amplitude between 2 V and 200 V. The signal must be static at least 2 μ s prior to the negative transition.

3-153. Hold Command. This is an internal command to a Sample/Hold amplifier, resulting in a Hold mode. Hold A command switches Amplifier A and Hold B switches Amplifier B. Both commands are generated in the Sample/Hold logic circuits.

3-154. External Encode. This command initiates a 3490A measurement when the Sample Rate control is set to HOLD. This signal must be from HIGH to LOW for a minimum of 240 μ s.

3-155. Special S/H Operating Considerations.

3-156. Display. When the 3490A is operating in either the Track/Hold or Acquire/Hold mode, the fifth digit in the display is normally blanked, leaving a display of 4 full digits plus the overrange "1". This is done because of the uncertainty in the fifth digit due to noise. However, if the instrument is equipped with the Data Output (BCD) Option 021 or the HP-IB Option 030, the output data includes the fifth digit. The fifth digit can be restored to the display if desired by changing the connection of the white/black wire from the display

assembly. For a 4-digit S/H display, this wire is connected to Test Point L on the Main Circuit Assembly, A1, and for a 5-digit display, it should be moved to Test Point M. These test points are located on the Main Circuit Assembly just to the rear of P2, which is the display cable connector.

3-157. .1 V Range. Sample/Hold measurement accuracy is not specified for the .1 V range. On this range, the output of the Input amplifier contains an appreciable amount of wideband noise due to the broad bandwidth of the amplifier and the amplifier gain of X100. The rapid response time of the Sample/Hold circuits allows the Hold mode to occur anywhere within the envelope of the noise.

3-158. Autoranging. Autoranging requires successive readings (initiated internally) when changing ranges. Consequently, the final reading loses its time relationship to the external trigger and therefore is not useful Sample/Hold information.

3-159. Guard Connection in Sample/Hold Measurements.

3-160. The Guard terminal should always be connected to the Low input terminal when making Sample/Hold measurements, unless the guard can be properly driven by a low-impedance and low-noise source.

3-161. Input Signal Limitations.

3-162. The analog-to-digital conversion process requires a certain amount of time, and any change in the voltage input to the A-to-D conversion circuits during this time degrades the accuracy of the measurement. The purpose of Sample/Hold is to "freeze", or hold, a changing input voltage at a specific point in time and accurately measure the voltage. The bandwidth of the Input Amplifier and the response time of the Sample/Hold Amplifiers restrict the rate at which the voltage to be measured can change. The Sample/Hold circuits are able to maintain tracking only if the rate of change of the input voltage is within the following limits:

2.5 % range/ μ s on the 10 V and 1000 V ranges.

5 % of range/ μ s on the 1 V and 100 V ranges.

The rate of change in input voltage (dV/dt) affects the ability of the instrument with Sample/Hold to digitize a ramp or sine wave. Table 3-8 shows the maximum dV/dt for a ramp and the maximum frequency for a full-range sine wave to be measured within the accuracy given. The input signal is also limited to a maximum dV/dt during digitization of 50 V/ μ s.

3-163. Sample/Hold Trigger Signal Requirements.

3-164. Either of two signal inputs may be used to initiate a Hold mode. The Sample/Hold Trigger input (TTL) is dc coupled, and the AC Trigger input, of

Table 3-8. Ability of Sample/Hold to Digitize a Ramp or Sine Wave.

Accuracy* (% of Range)	RANGE					
	10 V			1 V, 100 V, 1000 V		
	Ramp	Sine Wave (Zero Crossing)	Sine Wave (Peak Reading)	Ramp	Sine Wave (Zero Crossing)	Sine Wave (Peak Reading)
.01 %	30 V/S	5 Hz	750 Hz	12.5 V/S	2 Hz	300 Hz
.1 %	300 V/S	50 Hz	2750 Hz	125 V/S	20 Hz	900 Hz
1 %	3000 V/S	500 Hz	7500 Hz	1250 V/S	200 Hz	3000 Hz

*Accuracy specifications are to be added to (% of range) dc specification.

course, is ac coupled. The term "Sample/Hold Trigger" is used as a general term in this manual to refer to either signal. In some option combinations, a Sample/Hold Trigger does not initiate a 3490A measurement (see Paragraph 3-168).

3-165. Sample/Hold Trigger (TTL). Compatibility with TTL logic circuits requires this signal go be from HIGH ($\geq +2.4$ V) to LOW ($\leq +0.4$ V) for a minimum of 30 nanoseconds in order to initiate a Hold mode. The signal must be HIGH for at least 600 μ s prior to going LOW. The external triggering circuit must be capable of sinking 1 mA at $\leq +0.4$ V.

3-166. AC Trigger. The leading edge of a negative-going pulse at least 30 nanoseconds wide and 2 V to 200 V in amplitude initiates a Hold mode. The signal must be stable for at least 2 μ s before the negative-going transition.

3-167. Termination of Unused S/H Trigger Input Connections. When operating in a Sample/Hold mode, some precautions are necessary to prevent unwanted triggering of the Sample/Hold circuits, which can be caused by cross talk within an external cable attached to the trigger input connector. Only one of the two trigger inputs will be used at any one time in a given situation, and spurious triggering at the other input may be prevented in one of two ways:

1. The unused input may be left open; that is, with no wire in the cable connected to this pin on the connector.

2. The unused input may be terminated at the other end of the cable. The TTL Sample/Hold Trigger (dc coupled) input line should be connected to a HIGH logic level ($\geq +2.4$ V). The AC Trigger input line should be connected to a LOW logic level ($\leq +0.4$ V).

3-168. Initiating a Sample/Hold Measurement.

3-169. The Sample/Hold option is available in three different configurations which employ various methods of initiating a Sample/Hold measurement. Sample/Hold is available with the BCD/Remote Expand Option 020. (Either Data Output Option 021 or Remote Control Option 022 or both may also be installed with Option 020.) Sample/Hold is also available with the General Purpose Interface Bus I/O Option 030. In the third

configuration, Sample/Hold is available as Option 045, without any of the other options. No data output or remote control, except Sample/Hold Trigger, is available in Option 045. The following paragraphs discuss methods of initiating a measurement in instruments having the various options. Table 3-9 lists the methods of externally triggering a Sample/Hold measurement.

3-170. Internal Sample Control, Option 045 and Option 040 with Option 020. When the front panel Sample Rate control is set to any position except Hold and no Sample/Hold Trigger command is applied, the instrument will automatically hold and read the input signal at the sample rate selected. However, this method of operation provides only random sampling, since it is not possible to synchronize the measurement to any specific point in the input signal.

3-171. Internal Sample Control, Option 040 with Option 030. The 3490A with the HP-IB Option 030 may be programmed for internal sample control. If so, the instrument will automatically hold and read the input signal at the sample rate selected. Operating with internal sample control provides only random sampling, since the measurement is not synchronized to any specific point in the input signal.

3-172. External Triggering, Option 045. When Sample/Hold is present in an instrument with neither BCD Remote Expand Option 020 or HP-IB Option 030, it is designated as Option 045. In this case, either Sample/Hold Trigger command automatically initiates a measurement.

Table 3-9. Initiating S/H Measurements by External Triggering.

Sample/Hold Option	Other Options in the 3490A	Measurement Initiated By:
040	020	Separate External Encode command or Stretched Pulse Output connected to External Encode input.
040	030	Sample/Hold Trigger
045	neither 020 or 030	Sample/Hold Trigger

3-173. External Triggering, Option 040 with Option 020. With this combination of options, a Sample/Hold measurement may be initiated by external triggering in two ways. For either method, the 3490A measurement circuits must be in the "Hold" state. That is, the Sample Rate control must be in the Hold position, or if the instrument has Remote Control Option 022, the Interface Hold line may be held LOW. One method of initiating a Sample/Hold measurement requires two separate signal inputs, a Sample/Hold Trigger command to initiate a Hold mode, and an External Encode command to initiate a measurement. Both commands may be applied at the same time, or the External Encode command may be applied up to 1/2 second after the Sample/Hold Trigger. In the second method, the Stretched Pulse Output from the Sample/Hold trigger circuits (J7 pin 10) is connected externally to the External Encode input (J6 pin 46 or J7 pin 24 or 28). This connection provides an External Encode signal to initiate a measurement immediately upon receipt of a Sample/Hold Trigger command. Neither signal will have any effect if applied while a measurement is in progress. If a Sample/Hold Trigger command is given without an External Encode command, the Sample/Hold circuits will be locked in the Hold mode. This condition can be terminated by applying an External Encode command or by setting the Sample/Hold switch to Off.

3-174. External Triggering, Option 040 with Option 030. When the operating Sample/Hold with Hewlett-Packard Interface Bus control, the 3490A should be

programmed for Next External Trigger (T2). When Next External Trigger is programmed, upon completion of a measurement the HP-IB circuits wait for an External Trigger command. Either of the Sample/Hold Trigger inputs at J11 provides an External Trigger command to initiate a measurement at the same time a Hold mode is initiated.

3-175. Acquisition Time. The maximum time required by the DC Input and Sample/Hold Amplifiers to respond to an input voltage varies with the range selected, as shown in Table 3-10. The acquisition time must be taken into consideration in Track/Hold operation. The delay incorporated into Acquire/Hold operation includes the acquisition time. Figure 3-11 shows typical times required for the amplifiers to respond within a specified accuracy to a step input voltage.

Table 3-10. Maximum Acquisition (Settling) Time for Full-Range Step Input.

Range	Settling Time to Within 0.01 % of Final Value
1 V	512 μ s
10 V	128 μ s
100 V	512 μ s
1000 V	128 μ s

NOTE

.1 V range is not specified (see Paragraph 3-157).

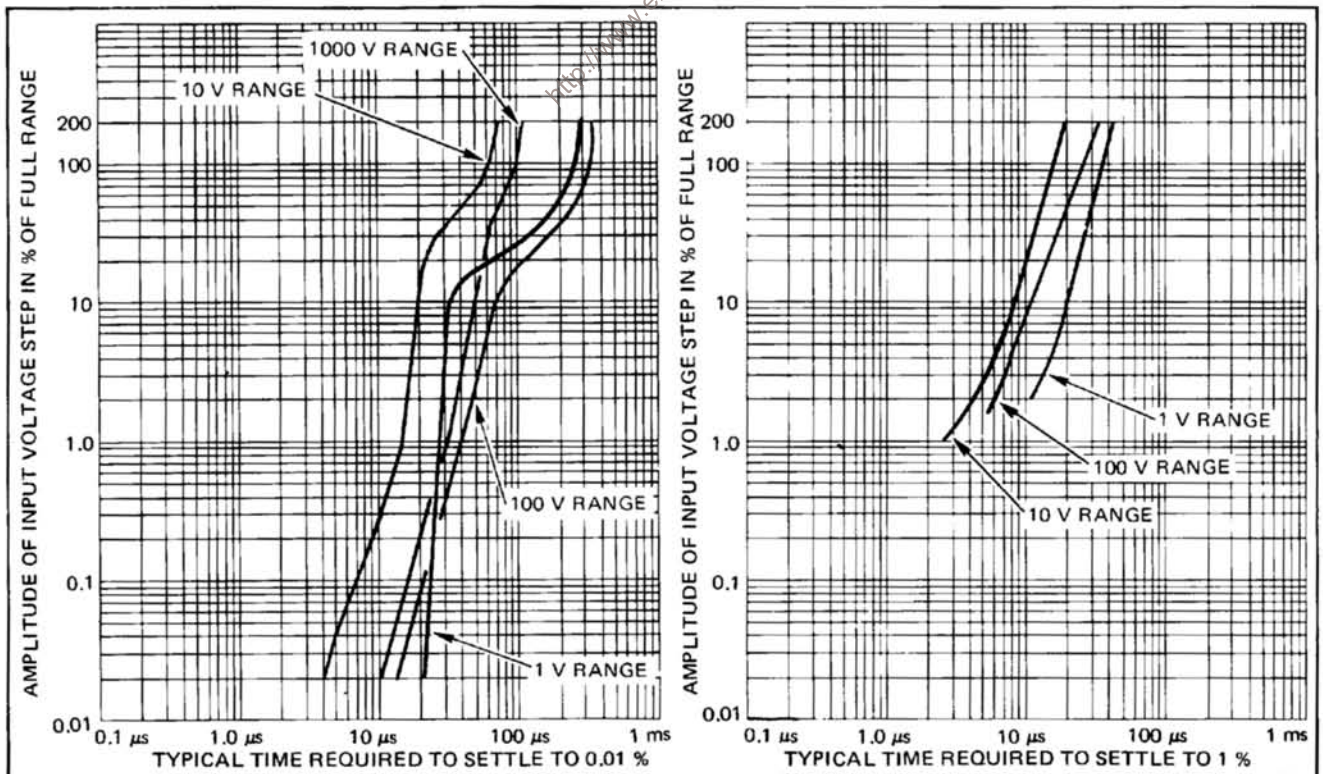

Figure 3-11. Typical Response to a Step Input Voltage.

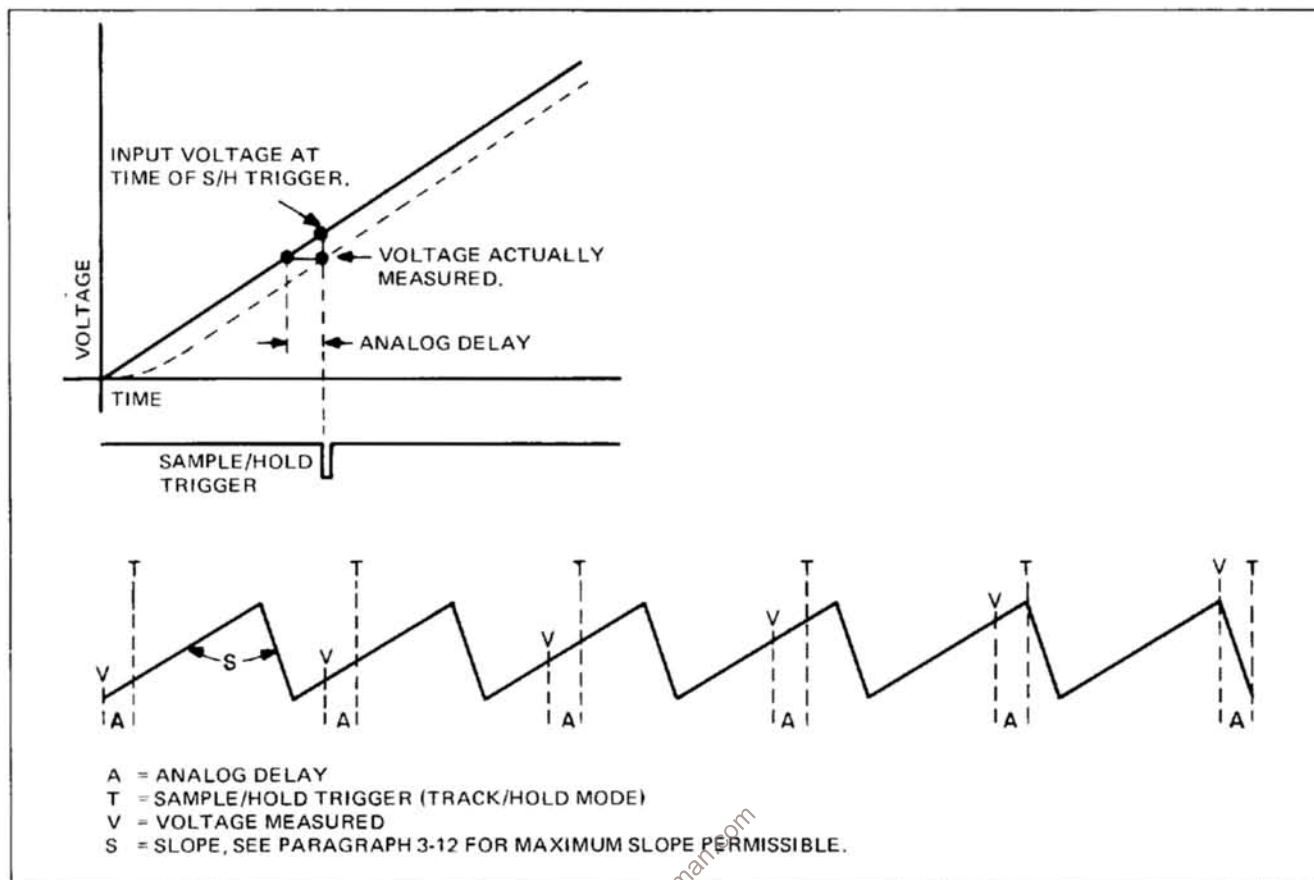

Figure 3-12. Digitizing a Ramp.

3-176. Using the Track/Hold Mode.

3-177. Digitizing a Ramp. The output of the Sample/Hold amplifier circuits lags the 3490A input voltage by a delay which is approximately equal to $\frac{1}{2 f_{3\text{ dB}}}$, where

$f_{3\text{ dB}}$ is the 3 dB bandwidth frequency shown in Table 1-2. When measuring a stable dc input voltage, this time lag presents no problem. However, if the input voltage is changing, as a ramp input for example, this delay must be considered in interpreting the 3490A reading. In Track/Hold measurements, the voltage reading is actually the input voltage at a point previous to the time the Sample/Hold Trigger command was received. The point of measurement, then, effectively precedes the trigger command by a length of time equal to the delay, shown in Figure 3-12 as the analog delay. Digitization of a repetitive stable ramp may be done as illustrated in Figure 3-12. The delay between the start of the ramp and the Sample/Hold Trigger must be accurately determined by some means, such as an interval timer. It is not necessary that measurements be made on successive cycles as might be inferred from Figure 3-12. Measurement may be made on every 2nd, 3rd or nth cycle as convenient, if the waveform is stable. The maximum dV/dt limitations shown in Paragraph 3-161 and Table 3-8 must be observed.

3-178. Reconstructing an Input Waveform. An input waveform may be reconstructed from a series of Track/Hold measurements by using the second equation shown in Table 1-2 under the "Time Response Characteristics" heading. The shorter the time between measurement points, the greater the accuracy of the reconstructed waveform will be.

3-179. Digitizing a Sine Wave. The rules that apply when digitizing a ramp (Paragraph 3-177) also apply to measurement of a sine wave. Keep in mind that the dV/dt and frequency limits given in Paragraph 3-161 and Table 3-8 must be observed. The waveform may be reconstructed from the Track/Hold measurement information as discussed in Paragraph 3-178.

3-180. Ramp Linearity Measurement Aided by an Oscilloscope. An oscilloscope with delayed sweep and a delayed gate output can be very helpful in making Sample/Hold measurements of a repetitive waveform. For example, linearity of a ramp can be measured accurately, as in the following procedure.

a. Choose an oscilloscope with delayed sweep, such as the -hp- Model 180C with the 1821A Time Base/Delay Generator plug-in unit. Be sure the Delayed Gate output from the oscilloscope meets the Sample/Hold Trigger input signal requirements given in Paragraph 3-163.

b. Connect the Delayed Gate output from the oscilloscope to the S/H AC Trigger input. If the 3490A has Option 020 installed, connect the S/H Stretched Pulse Output to the External Encode input (see Paragraph 3-173).

c. Connect both the Main Gate and Delayed Gate outputs from the oscilloscope to an interval timer (such as the -hp- Model 5300A/5302A) to determine the delay time accurately.

d. Connect the ramp signal to be measured to both the 3490A input and the oscilloscope vertical input. The slope of the ramp must be within the limits given in Paragraph 3-161 and Table 3-8. Trigger the oscilloscope main sweep at the beginning of the ramp.

e. Set the Sample/Hold control to Track/Hold. The measurement will then be triggered at the point where the delayed-sweep intensified trace appears along the ramp.

f. Position the delayed-sweep intensified trace at any number of sampling points (at least three) along the ramp, as shown in Figure 3-13.

g. The slope of the ramp between various measurement points can then be compared to determine linearity. In Figure 3-13, for example, slope AB should be compared to slope BC as follows:

$$\text{Slope AB} = \frac{V_B - V_A}{T_B - T_A}$$

$$\text{Slope BC} = \frac{V_C - V_B}{T_C - T_B}$$

$$\% \text{ Non-Linearity} = \frac{\text{Slope BC} - \text{Slope AB}}{\text{Slope AB}} \times 100$$

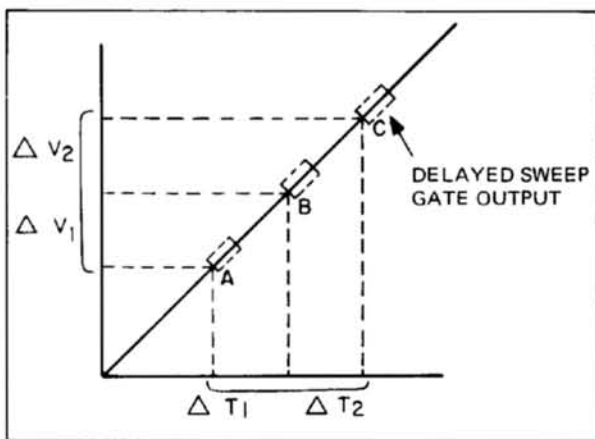

Figure 3-13. Using Delayed-Sweep Oscilloscope in Ramp Linearity Measurements.

3-181. Filter Response Measurement Aided by an Oscilloscope. Measurement of filter response may be accomplished by the use of Sample/Hold, a delayed-sweep oscilloscope, a square wave generator, and a time interval counter. The following procedure tests the response time of a filter.

a. Choose an oscilloscope with delayed sweep, such as the -hp- Model 180C with the 1821A Time Base/Delay Generator plug-in unit. The vertical plug-in may be either single- or dual-channel. However, the dual-channel feature permits display of both the filter input and output at the same time. Be sure the Delayed Gate output from the oscilloscope meets the Sample/Hold Trigger input signal requirements given in Paragraph 3-163.

b. Connect the Delayed Gate output from the oscilloscope to the S/H AC Trigger input. If the 3490A has Option 020 installed, connect the S/H Stretched Pulse Output to the External Encode input (see Paragraph 3-173).

c. Connect both the Main Gate and Delayed Gate outputs from the oscilloscope to an interval timer, such as the -hp- Model 5300A/5302A Counter, to determine the time delay accurately.

d. Connect a square wave generator, such as the -hp- Model 3311A Function Generator, to both the filter input and the oscilloscope input. Set the square wave output to 10 V at a frequency such that the duration of one half of the square wave is greater than the expected response time of the filter. For example, a frequency of 300 Hz is satisfactory for the filter shown in Figure 3-14.

e. Set the 3490A to the 10 V range, DC function and Track/Hold operation. Connect the output of the filter to the 3490A input terminals. If a dual-channel oscilloscope is used, also connect the filter output to the other oscilloscope input.

f. Position the delayed sweep intensified trace toward the right side of one half of the square wave and determine the final value of the filter output.

g. Shift the intensified trace toward the left until the 3490A reading is reduced to within X % or X mV of the final value noted in step f. The time interval counter displays the time required to settle to this value. The intensified trace may be positioned at the other points to observe any overshoot or ringing in the filter output.

3-182. Using the Acquire/Hold Mode.

3-183. Measuring a Step Input Voltage. The Acquire/ Hold mode of operation is useful for measuring a step input voltage because the Sample/Hold Trigger command may be applied simultaneously with the input voltage step. The aperture time, which is the delay

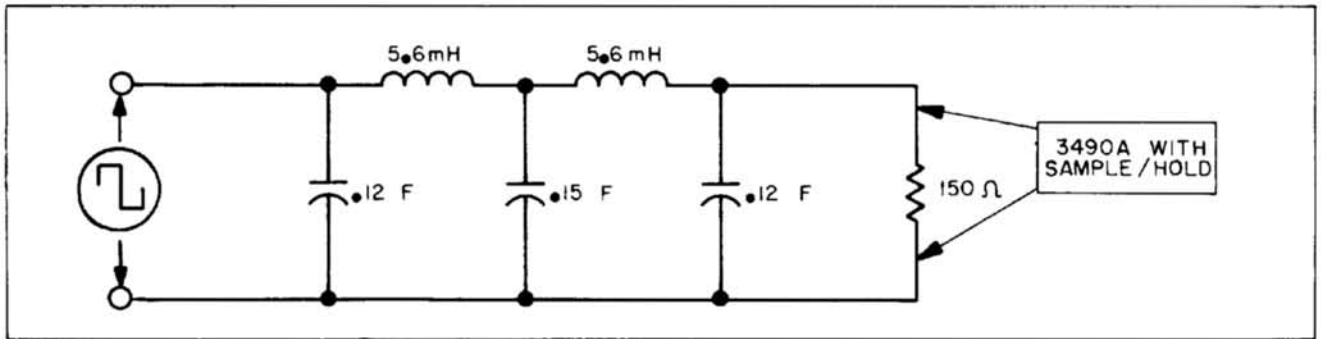

Figure 3-14. Filter Output Measurement.

between receipt of a Sample/Hold Trigger and the beginning of a Hold mode, is of sufficient length to include the acquisition time, as shown in Figure 3-15. The step input voltage must remain stable for at least the duration of the Acquire/Hold aperture time shown in Table 1-2.

3-184. Measuring Pulse Height. Acquire/Hold may be used to measure the height of a pulse or square wave. The width of the pulse (or one-half of the square wave) must be greater than the aperture time shown in Table 1-2. Triggering may be applied coincident with the leading edge of each input pulse.

3-185. Using 50 Hz or 60 Hz Power Source (Options 050 or 060).

3-186. The 3490A has the capability of operating from a 50 Hz or 60 Hz power source. Option 050 is available for 50 Hz operation and consists of using a 3.333 MHz crystal (Y2) in the clock and A1R207 = 100 kΩ. Option 060 provides for 60 Hz operation and uses a 4 MHz crystal (Y1) in the clock and A1R207 = 84.5 kΩ. See Table 2-1.

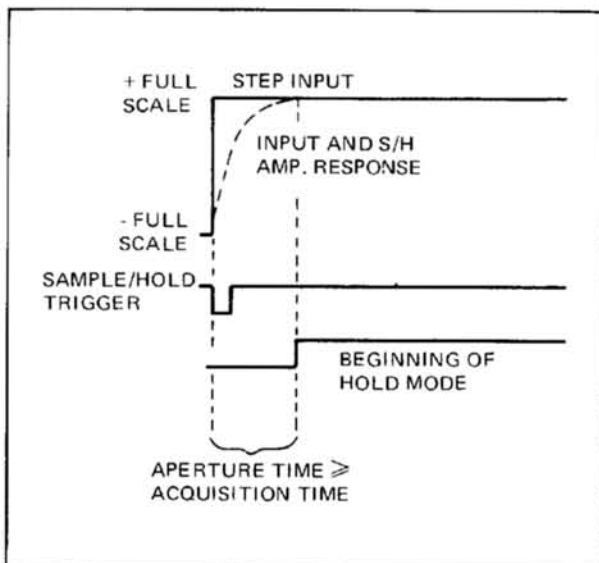

Figure 3-15. Measurement of a Step Input.

3-187. RATIO MEASUREMENTS (Option 080).

3-188. Instructions for making ratio measurements with the Model 3490A, Option 080, are contained in the following paragraphs. DC-to-dc and ac-to-dc "three-wire" ratio measurements can be made; that is, the EXT REF input Low terminal and the INPUT Low terminal are connected internally. Because the same terminals are used for Ohms measurements and for Ratio measurements, these two functions are mutually exclusive.

3-189. External Reference Voltages.

3-190. The front panel RATIO switch selects either the internal Reference or the 1 V or 10 V External Reference range. If the 1 V range is selected, the external reference voltage may be either a positive or negative voltage between 0.1 V and 1.2 V. On the 10 V range, the reference may be positive or negative, 1 V to 12 V.

3-191. Input Connections.

3-192. The dc external reference and unknown input voltage should be connected as shown in Figure 3-16.

CAUTION

External Reference Low and Input Low must be at the same potential; these terminals are connected internally. Connect Guard to Input Low.

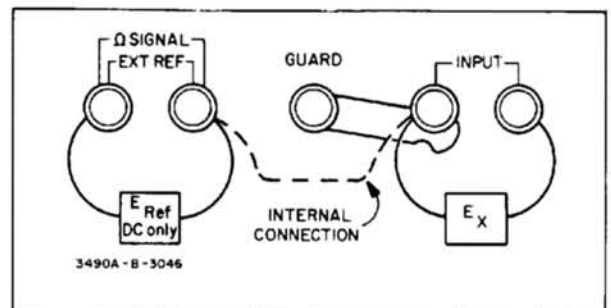

Figure 3-16. Ratio Input Connections.

3-193. Ratio Display.

3-194. If the 1 V External Reference range is selected, the display reads the ratio directly, but if the 10 V reference range is used, multiply the display by 0.1. In dc/dc ratio measurements, the polarity symbol is + when the external reference and input voltages are the same polarity, and - if they are opposite in polarity (see Table 3-11). In ac/dc measurements, no polarity symbol is displayed. Any ratio measurement is limited to 120 % of the input range selected. If autoranging is selected, upranging occurs at 120 % of range and downranging at 10 % of range. Overload indication is the same as in voltage measurements.

3-195. Ratio Measurement Procedure.

- a. Set RATIO switch to 1 V or 10 V EXT REF range. If the external reference voltage is between 1.0 V and 1.2 V, the 1 V range should be used for greater accuracy.
- b. Connect External Reference (dc only) to EXT REF terminals.
- c. Select DC or AC FUNCTION to correspond to input signal to be measured.
- d. Set RANGE switch to desired range or to AUTO.

Table 3-11. Ratio Polarity Display.

External Reference Input	Input Signal	Displayed Polarity
+	+	+
+	-	-
-	+	-
-	-	+
+	ac	none
-	ac	none

e. Connect input signal (dc or ac). Input signal Low and External Reference Low must be at same potential, since these terminals are connected internally.

f. Read ratio display directly if 1 V EXT REF range is selected. If 10 V EXT REF range is selected, multiply display by 0.1.

NOTE

When operating in Autorange mode with less than full-scale External Reference input (<1 V or <10 V), the first reading following an uprange will be incorrect.

<http://www.ebaman.com>

SECTION IV THEORY OF OPERATION

4.1. INTRODUCTION.

4-2. This section describes the methods and circuits used in the Model 3490A Multimeter to make dc voltage, ac voltage, and resistance measurements. The circuits needed for ratio measurement, sample-and-hold measurements, remote control, and data output are also described. A general theory of operation is followed by a more detailed explanation of the circuits used.

4.3. GENERAL THEORY OF OPERATION.

4-4. The Model 3490A Multimeter uses the dual-slope integration technique for measurement (see Figure 4-1), in which an integrator charges for a fixed length of time to a voltage proportional to the input signal, and then is discharged at a fixed rate determined by a known reference voltage. The measurement display is determined by the discharge time, which is proportional to the input signal. The integrator is part of the Analog-to-Digital Converter shown in the Basic Block Diagram in Figure 4-2. A description of the basic operation of the 3490A is contained in Figure 4-2 and Paragraphs 4-5 through 4-18.

4-5. Signal Conditioning Circuits.

4-6. The signal conditioning circuits include the DC Input Attenuator, the AC Converter, and the Ohms Converter circuits. The output of one of these circuits is applied to the DC Amplifier for the run-up portion of the measurement sequence.

4-7. Reference Voltages.

4-8. One of three reference voltages is applied to the DC Amplifier input for the run-down portion of the

measurement sequence. The proper reference is selected by the Logic circuits according to the function selected and/or the polarity of the input signal.

4-9. DC Amplifier.

4-10. The DC Amplifier output is 10 Vdc for a full-range input on any range in any function. For any measurement except Sample/Hold, this output goes to the Analog-to-Digital Converter circuits. In Sample/Hold measurements, the DC Amplifier output is applied to the Sample/Hold circuits (see Figure 4-21), and the Sample/Hold output is applied to the A-to-D Converter.

4-11. Analog-to-Digital Converter.

4-12. The Analog-to-Digital (A-to-D) conversion circuits consist of an Integrator, followed by a $\times 20$ Amplifier and a Zero Detect Amplifier. If the Integrator input is positive during run-up, the A-to-D output goes HIGH (near +5 V) during run-up and returns to LOW (near 0V) when the Integrator is discharged to zero. If the input is negative, the A-to-D output goes LOW during run-up and HIGH at the zero detect point. Input signal polarity, as well as "end of measurement" information, is derived from this output signal. The length of time between the start of run-down and the zero detect point determines the numerical value of the display.

4-13. Logic.

4-14. The timing of the measurement sequence is controlled by the logic circuits. This timing may be influenced by the range and function selected. The basic clock is a crystal-controlled oscillator, from which a number of timing signals are derived through dividing counters. The sample rate is controlled by the logic

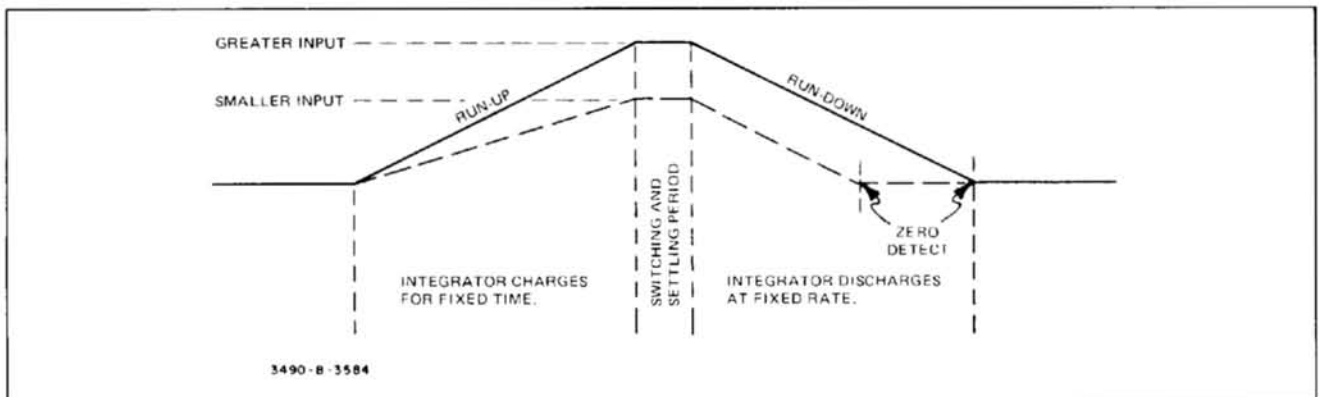

Figure 4-1. Dual-Slope Integration.

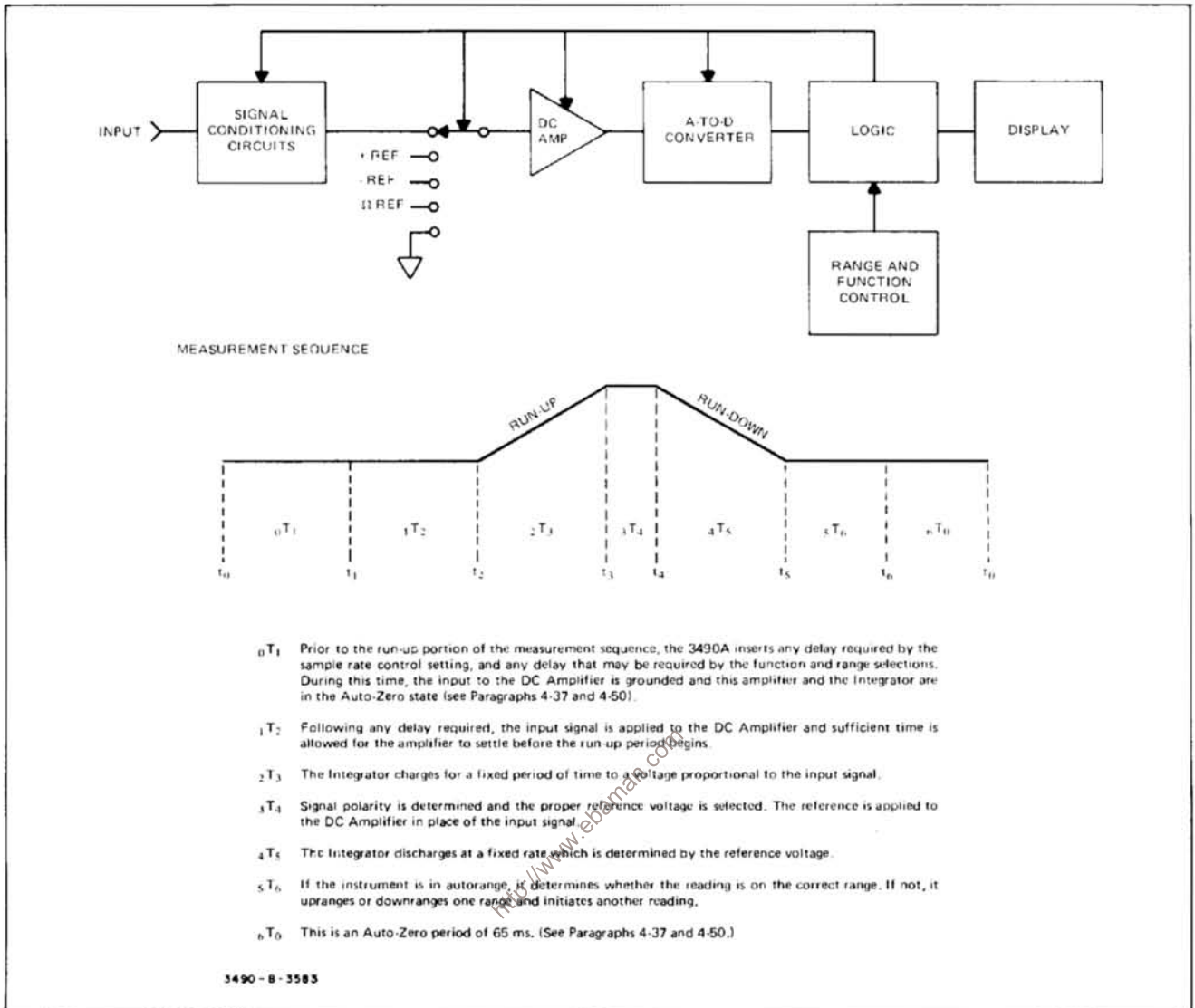

Figure 4-2. Basic Diagram and Operation.

circuits, and is dependent upon the sample rate switch setting, as well as the function and range selected. In auto-range operation, the logic circuits select the correct range. The input polarity information is utilized by the logic circuits to select the correct reference polarity for run-down.

4-15. Display.

4-16. The display consists of six digits; however, the most significant digit is either zero or an overrange "1" during normal measurements. During the logic test operation (Test No. 1), other numbers are displayed in this digit. The display also contains a polarity symbol and an "overload" annunciator light. If the instrument has a Remote Control option, a "REM" annunciator also lights when remote operation is selected.

4-17. Range and Function Control.

4-18. Range and function may be selected by the front panel switches or remotely, if the instrument is equipped with one of the remote control options. Remote control is provided by Option 022 (Paragraph 4-174), or by the General Purpose Interface Bus I/O Option 030 (Paragraph 4-196).

4-19. DC ANALOG CIRCUITS.

4-20. In general, the following explanations of both the analog and digital circuits describe the circuits outlined in the block diagram shown in Figure 7-18.

4-21. Input Attenuator.

4-22. A simplified diagram of the Input Attenuator and DC Amplifier circuits is shown in Figure 4-3. The Input

Attenuator is switched by reed relays which are controlled by signals from the DC Switching Logic circuits. No attenuation is used on the .1 V, 1 V and 10 Vdc Ranges. Attenuation of 100 is used on the 100 V and 1000 V ranges. No attenuation is required for resistance measurements, because the full-range voltage across the resistance being measured is not greater than 10 V. In ac voltage measurements, the AC Converter output is applied to the DC Amplifier through a FET (Field Effect Transistor) switch, and the dc attenuator is not used.

4-23. DC Amplifier.

4-24. The DC Amplifier is a differential amplifier circuit using a FET input stage to provide an input resistance greater than 10^{10} ohms on the .1 V, 1 V and 10 V ranges. Input resistance on the 100 V and 1000 V ranges is $10\text{ M}\Omega$, as determined by the attenuator. The push-pull output stage is protected by diodes which prevent excessive output current. The amplifier output is + or - 10 V full range for all ranges and functions. In normal operation, this output is applied to the Integrator circuit. If optional Sample/Hold operation is selected, the DC Amplifier output is applied to the Sample/Hold Analog circuits.

4-25. DC Amplifier Gain.

4-26. The gain of the DC Amplifier may be 1, 10 or 100, and is determined by the feedback path selected. FET switching circuits are used to select the feedback resistance ratios, and the gain is equal to $\frac{FR1 + FR2}{FR2}$, as shown in Figure 4-3.

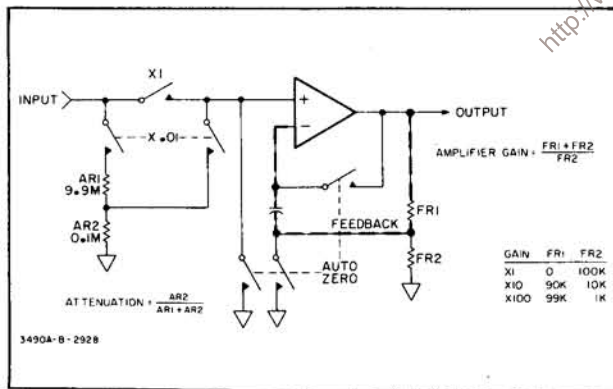

Figure 4-3. Simplified Diagram, DC Amplifier.

4-27. Switching Circuits.

4-28. Figure 4-4 shows the 3490A measurement sequence. During the charging, or run-up period, the input signal is applied to the DC Amplifier input. During the discharge, or run-down period, the proper reference is applied. Switching of these signals and others such as a Feedback Attenuator and Auto Zero circuits, is accomplished by FET switching circuits. These FETs are all contained in one microcircuit package, A2U2, and are driven by signals from the DC Switching Logic circuits.

4-29. Bootstrap Circuit.

4-30. The gate-to-source bias for the switching FETs is provided by a voltage which is bootstrapped to the DC Amplifier input voltage to provide the proper turn-on and turn-off bias. The input of the unity-gain Bootstrap Amplifier, shown in Figure 7-20, is connected to the DC Amplifier feedback line.

4-31. Reference Voltages.

4-32. Internal reference voltages are provided for the run-down portion of the measurement sequence. In dc measurements, if the input voltage is positive, the - 10 V reference is used; and if the input is negative, the + 10 V reference is used. In ac measurements, the AC Converter output is positive requiring the negative reference for run-down. The Ω reference, used in resistance measurements, is generated by the Ohms Converter and is approximately - 1 V.

4-33. Overload Protection.

4-34. Protection against excessive input voltage is provided at the DC Amplifier input. On the 10 V, 100 V and 1000 V ranges, the input is limited by breakdown diodes to approximately ± 13 V. On the .1 V and 1 V ranges, the protection circuits are switched to limit the input to the amplifier to approximately ± 2 V. Overload protection is also provided at the amplifier output by a diode circuit in parallel with the feedback attenuator. If, for example, the amplifier is operating with a gain of 10 or 100 and the output voltage exceeds approximately + 16 V, the diode circuit begins to conduct, reducing the amplifier gain, with a corresponding reduction in output voltage. If the amplifier is operating with a gain of 10 or 100, the gate of the x1 gain FET (K in Figure 4-4) is at - 17 V. If the amplifier output goes excessively negative, as it approaches - 17 V, the x1 gain FET begins to turn on, reducing the amplifier gain and its output voltage. Consequently, the amplifier output is limited to approximately ± 16 V.

4-35. Leakage Control.

4-36. A FET switch (B in Figure 4-4) is also provided which disconnects the three reference FETs (F, G, H), the AC Converter output FET (E), and the .01 Attenuator FET (D) from the amplifier input during run-up when the x1 Attenuator line is being used. This reduces the possibility of leakage from these circuits into the high impedance DC Amplifier input circuit.

4-37. DC Amplifier Auto Zero.

4-38. During certain portions of the measurement sequence, as shown in Figure 4-4, the DC Amplifier circuit is automatically zeroed. At the completion of a measurement, the amplifier input is grounded through the Input Short FET switch C. The Auto Zero signal then turns on FET switch J, placing the amplifier in a x1 gain

SEE NOTES ON FOLLOWING PAGE.

MEASUREMENT SEQUENCE FOR FULL RANGE NEGATIVE INPUT. NOT DRAWN TO TIME OR VOLTAGE SCALE. ALL TIMES SHOWN ARE FOR 60 Hz OPTION. FOR 50 Hz OPTION, INCREASE TIMES BY 20%.

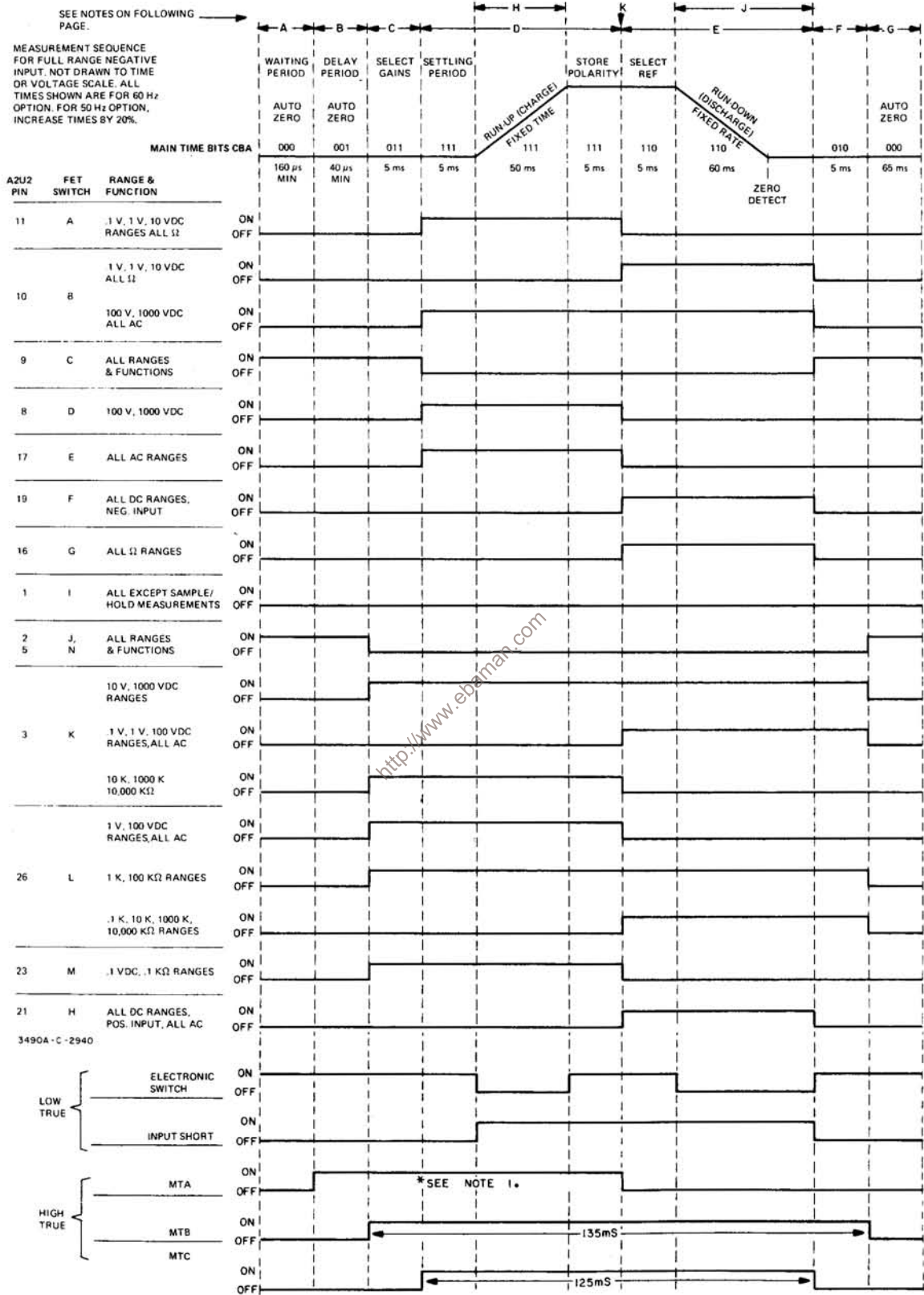

Figure 4-4(a). Measurement Sequence.

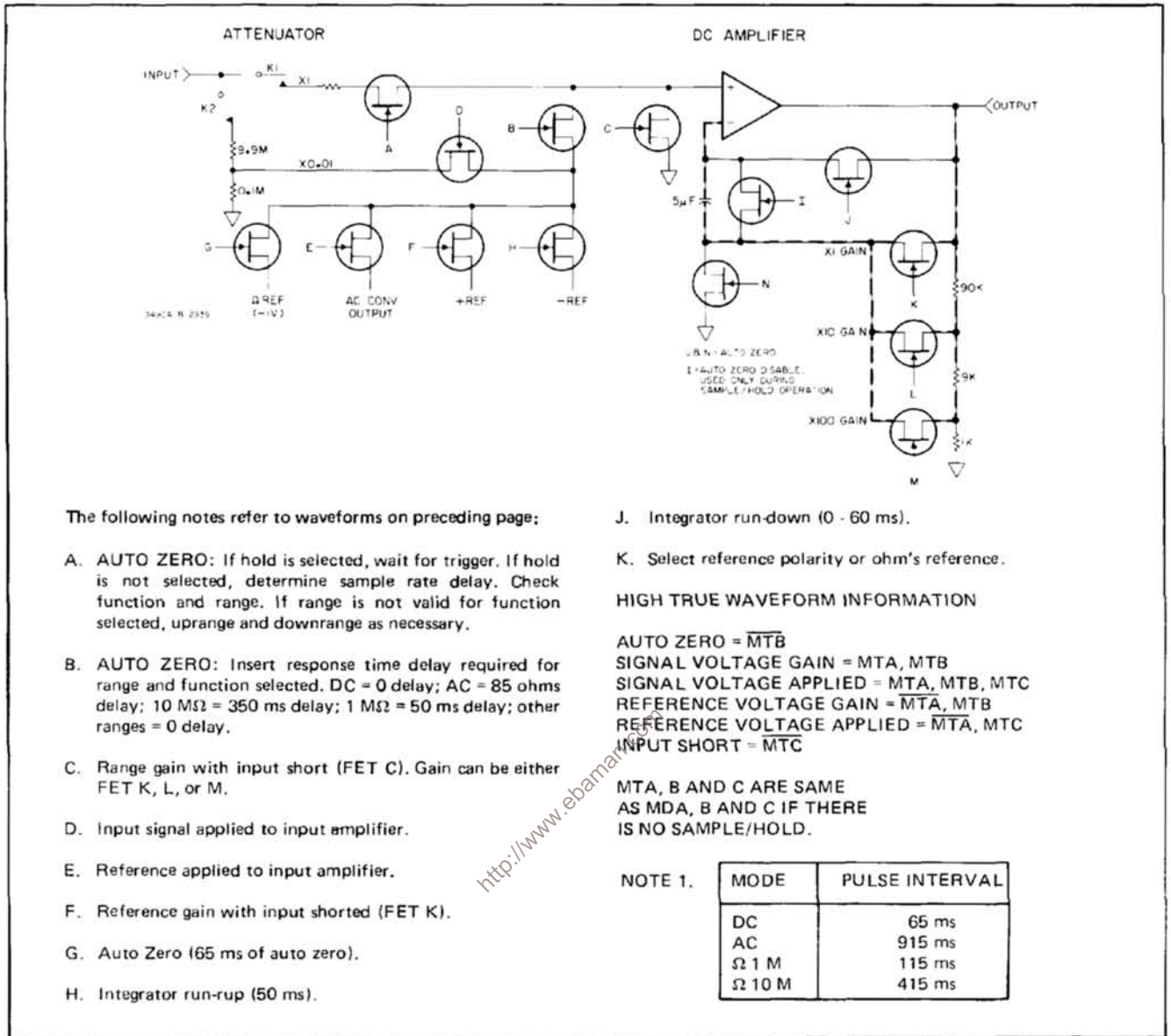

Figure 4-4(b). Measurement Sequence Notes.

configuration. At the same time, FET switch N grounds the feedback capacitor. As a result, the capacitor is referenced to ground and the amplifier input is held at zero during the Auto Zero period. Any residual offset in the amplifier is stored in the feedback capacitor. During the following measurement, the voltage stored in the capacitor appears at the inverting input of the amplifier and cancels the amplifier offset.

4-39. INTEGRATOR CIRCUITS.

4-40. Dual-Slope Integration.

4-41. The 3490A uses the dual-slope method of analog-to-digital conversion. The integrator charges for a fixed period of time, as indicated in Figure 4-4. The charging rate and resulting amplitude of the charge are proportional to the input signal. The integrator is then

discharged at a fixed rate determined by a known reference voltage. Since the discharge rate is constant, the discharge time is proportional to the amplitude of the charge (and the input signal). The Data Counter accumulates the number of clock pulses received during the discharge time, and this number is then displayed as the measurement amplitude. Figure 4-5 is a simplified diagram of the Integrator circuits.

4-42. Integrating Amplifier.

4-43. The output of the DC Amplifier is applied to the Integrator through the FET switch at its input only during run-up and run-down. The Integrating Amplifier is inverting, so if, for example, the input voltage is positive during run-up, the integrator output ramp is negative.

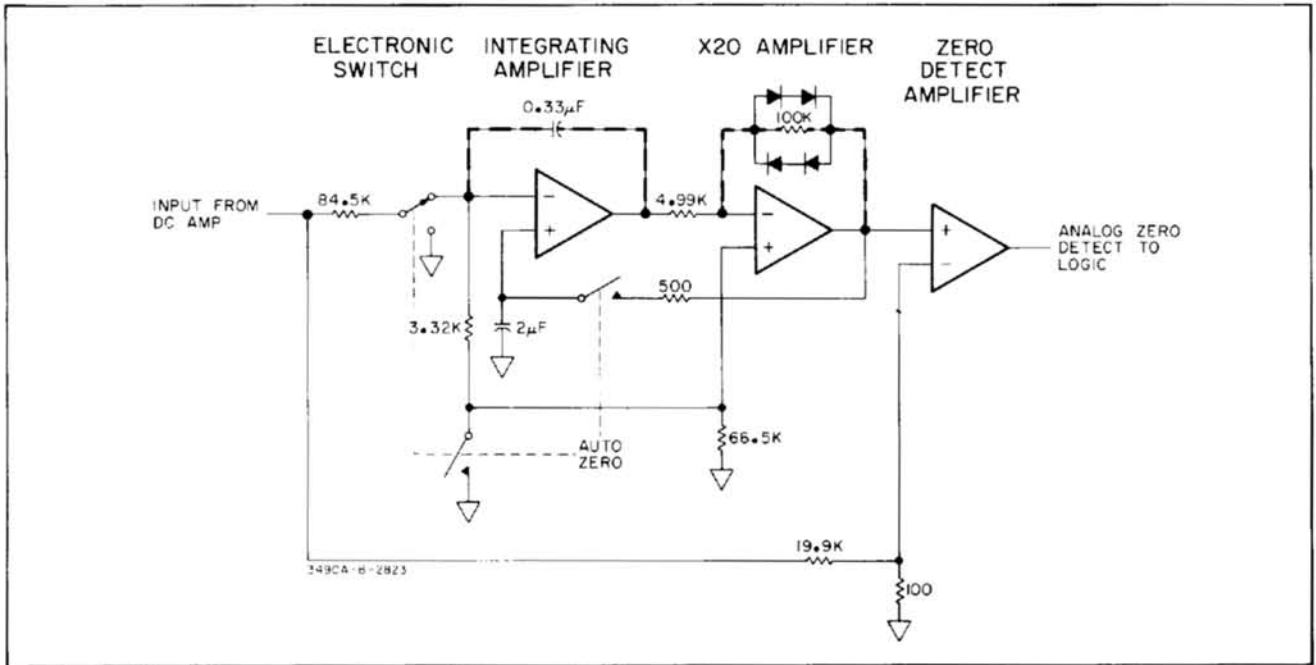

Figure 4-5. Simplified Diagram, Integrator Circuits.

4-44. x 20 Amplifier.

4-45. The output of the Integrating Amplifier is applied to an inverting amplifier having a gain of 20, whose output is limited to approximately ± 0.6 V by a parallel complementary diode connection between its input and output. This output is then applied to the Zero Detect Amplifier. A feed-forward connection is made from the Integrator input to the non-inverting input of the x 20 Amplifier. This reduces noise and switching transients generated at the integrator, since any noise is applied to both inputs of the x 20 Amplifier simultaneously.

4-46. Zero Detect Amplifier.

4-47. The Zero Detect Amplifier is a high-gain operational amplifier. If the Integrator input is positive during run-up, the Analog Zero Detect Output goes HIGH during run-up and returns to LOW at the Zero Detect point. If the input is negative, the Analog Zero Detect Output goes LOW during run-up and HIGH at the Zero Detect point. A fixed percentage of the reference voltage is applied to the inverting input of the Zero Detect Amplifier to determine the level at which Zero Detect will occur. The Analog Zero Detect output goes to the Zero Detect logic circuits.

4-48. Electronic Switch.

4-49. Two FET switches at the input to the Integrator act as a single-pole double-throw switch. During run-up and run-down, the Integrator input is connected to the DC Amplifier output, and at all other times it is connected to ground.

4-50. Integrator Auto Zero.

4-51. Any charge remaining on the integrating capacitor at the end of run-down must be removed before the beginning of the next measurement. The Auto Zero Circuit accomplishes this by connecting one input of the Integrating Amplifier to ground and the other to the x 20 Amplifier output. Using its own inverted output as a reference, the Integrator then discharges through an RC circuit. Since the Integrating Amplifier is grounded during Auto Zero, any residual offset in the Integrating and x 20 Amplifiers will be stored in the Auto Zero $2\mu\text{F}$ capacitor (see Figure 4-5). During the following measurement, this voltage stored in the capacitor cancels the amplifier offset.

4-52. AC CONVERTER.

4-53. The AC Converter used in the 3490A is an average responding circuit, calibrated to the rms value of a sinusoidal input. A simplified diagram is shown in Figure 4-6.

4-54. AC Attenuators.

4-55. Ranging in the AC function is accomplished by attenuating the input signal and adjusting the amplifier gain, which is inversely proportional to the feedback voltage. Table 4-1 shows the attenuator and amplifier gains for each range. The converter output is +1 Vdc for full-range input on all ranges.

4-56. Converter Amplifier.

4-57. A dual FET is used in the input stage of the AC-to-DC Converter Amplifier to maintain a high input impedance. Two ac feedback paths are provided, so that

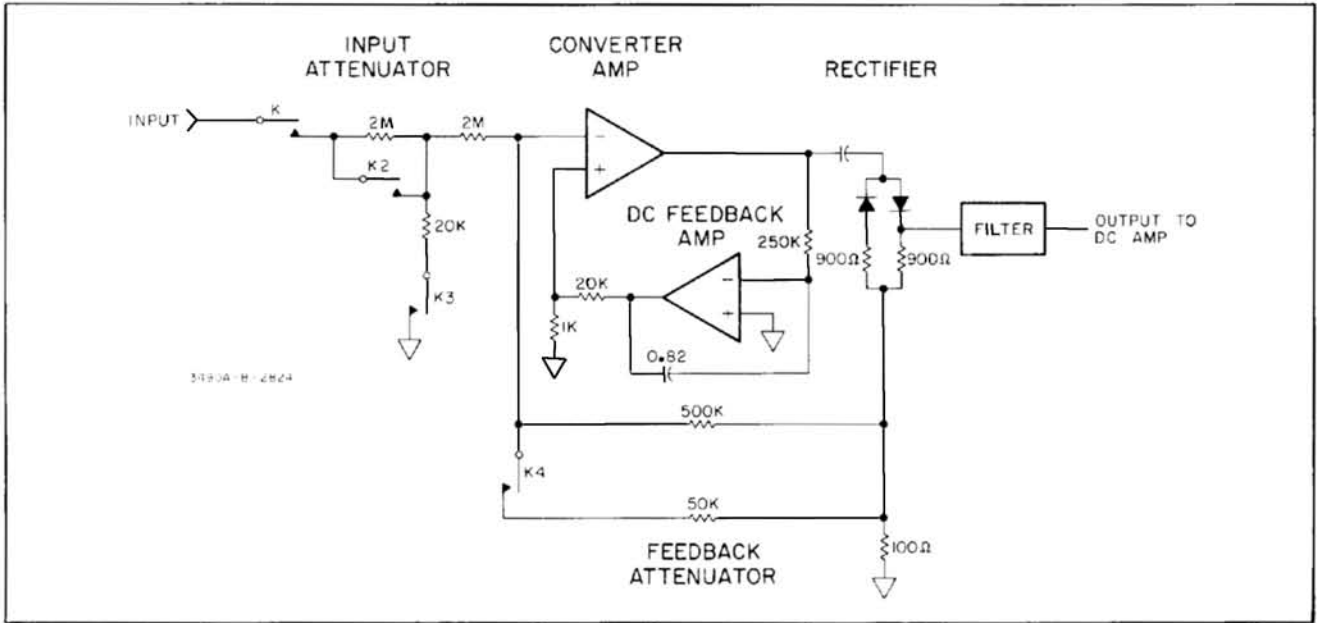

Figure 4-6. Simplified Diagram, AC Converter.

Table 4-1. AC Amplifier Ranging.

Range	Input Attenuator	Amplifier Gain	Total Gain
1 V	1	1	1
10 V	1	0.1	0.1
100 V	0.01	1	0.01
1000 V	0.01	0.1	0.001

a gain of 1 or gain of 0.1 may be selected. DC feedback stabilization is provided through an integrating amplifier. Saturation of the Converter Amplifier is prevented by a diode protection circuit which limits the output to approximately ± 7 V peak.

4-58. Rectifier and Filter.

4-59. The output of the Converter Amplifier is rectified by a half-wave rectifier, resulting in a positive output. A complementary diode in parallel with the output rectifier diode is used to provide a full-wave ac feedback to the amplifier input. Active filtering is used so that the necessary filtering can be obtained with capacitors of a practical size. In ac measurements, the output of the converter is applied through a FET switch (E in Figure 4-4) to the DC Amplifier during run-up.

4-60. OHMS CONVERTER.

4-61. The Ohms Converter supplies a reference current through the resistance being measured. The resulting voltage drop, which is proportional to the resistance, is measured in the same manner as a dc voltage input, except that the Ω Reference is used for run-down. A resistance measurement, then, is the ratio of the voltage developed across the unknown resistance, to the Ω

Reference voltage. A simplified diagram of the Ohms Converter is shown in Figure 4-7.

4-62. Current Source.

4-63. One input of the operational amplifier in the current source is referenced to ground. The Ω Reference voltage (approximately -1 V) is applied to the other input through a reference resistance, R_{ref} , whose value is selected according to the ohmmeter range. The nature of an operational amplifier is such that it tends to maintain both inputs at the same potential. This requirement cannot be satisfied by current drawn from the FET input; consequently, it must be met by the feedback current, which passes through the resistance being measured, R_x . As the amplifier output goes negative because of the negative input, the transistor at its output is forward biased. The resulting feedback current is automatically adjusted by the amplifier to cause a 1 V drop across R_{ref} . The value of the current, then, is inversely proportional to the value of R_{ref} .

4-64. Ohmmeter Power Supply.

4-65. An output from the State Clock (see Logic Circuits) is applied to a divide by six counter. The counter output is then applied to both ends of a center-tapped transformer primary. (The signal at one end is inverted and the other is not.) The output of the transformer secondary is rectified by a full-wave rectifier, and this floating voltage is used as a supply for the Ohms Converter circuits. This permits 4-terminal resistance measurements, since the Ω Signal Low is not internally connected to circuit common during run-up. The Ohmmeter Power Supply is disabled during all measurements except resistance measurements.

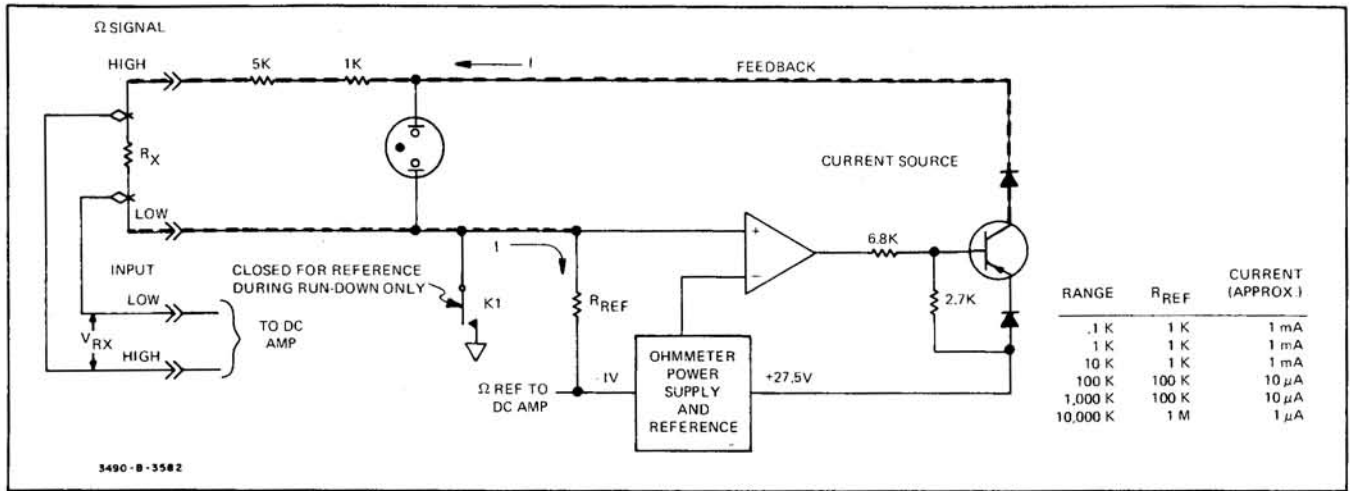

Figure 4-7. Simplified Diagram, Ohms Converter.

4-66. Ohmmeter Reference.

4-67. An emitter follower, whose base is referenced through a voltage divider to a 5.6 V zener diode, provides a stable reference of approximately -1 V across the reference resistor R_{ref} (Figure 4-7). This reference voltage, applied to R_{ref}, determines the amount of current supplied to R_x by the current source, as explained in Paragraph 4-62. A resistance measurement, then, is the ratio of the voltage across R_x to the voltage across R_{ref}, both voltages being determined by the current resulting from the reference voltage.

4-68. Input Protection.

4-69. Protection against excessive voltage which may be accidentally applied to the front panel Ω Signal terminals is provided by a gas discharge device across the terminals and a resistance in series with the high terminal. Voltages in excess of 250 Vrms may destroy the 1 kΩ series resistor.

4-70. DISPLAY ASSEMBLY (Figure 7-27).

4-71. Display Units.

4-72. The display consists of six seven-segment numerical display units, each containing a decimal point to the left of the segments. The display also contains a polarity and sample rate unit. Individual LED annunciators are located to the right of the seven-segment display units.

4-73. Scan Generator.

4-74. The Scan Generator develops the three scan signals SCAN A, SCAN B and SCAN C. The Scan Generator contains an oscillator (A3U1) and a divide-by-three counter (A3U2). The oscillator develops a 2 kHz SCAN A signal which is applied to the divide-by-three counter. The divide-by-three counter develops the SCAN B and SCAN C signals each at a frequency of 667 Hz. The scan signals A, B and C are applied to the Scan Decoder, A3U4, which activates one digit of the

display at a time scanning from the least significant digit to the most significant digit. The scan signals A, B and C are also used in the Data Output and Remote circuits.

4-75. BCD-to-Seven-Segment Decoder.

4-76. BCD count information is transmitted from the Data Counter to the BCD-to-Seven-Segment Decoder, A3U5, by data lines A, B, C and D. The BCD data is converted to a seven-segment code and applied to all displays simultaneously. The Scan Decoder activates one digit at a time to display the seven-segment code present at that time. The RBI input of the decoder (A3U5 pin 4) is driven by the Sample/Hold line and the DSM1 scan line applied thru inverters and a NAND gate. This blanks DSM1 in the Sample/Hold function.

4-77. Polarity Display.

4-78. The function signals, from either the front panel switch or remote control, are gated so that the symbol is disabled during ac and ohms measurements. When the symbol is enabled, the minus sign is on continuously, and the vertical bar is turned on when the reading is positive. The sample rate indicator, contained in the polarity unit, is on when Main Timing Bit A is HIGH.

4-79. Decimals and Annunciators.

4-80. Range information from the Range Counter is gated to turn on the correct decimal for each range. The Overload annunciator is turned on by the Overload signal stored in the Logic. The Remote annunciator is driven by a circuit on the Remote Assembly. The other annunciators (optional) are turned on by gating the Function signals. Each annunciator is a single LED.

4-81. LOGIC CIRCUITS.

4-82. Clock.

4-83. Figure 4-8 is a block diagram of the Clock and Counter circuits. The basic timing for the 3490A Logic

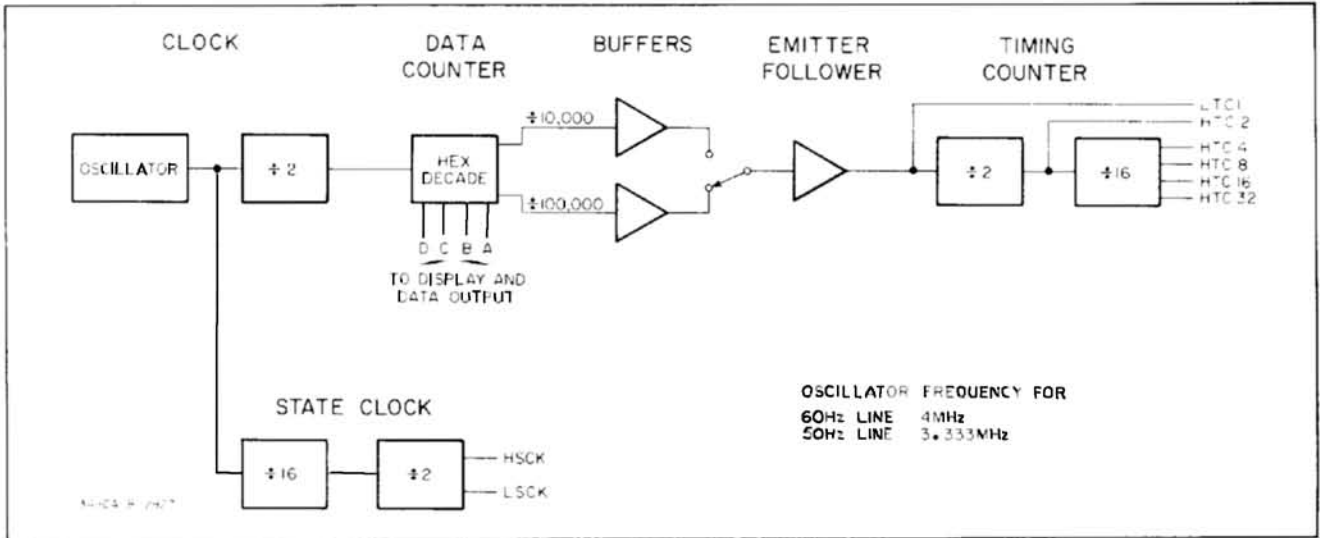

Figure 4-8. Block Diagram, Clock and Counters.

is derived from a Clock Oscillator which drives the Data Counter, a Timing Counter, and the State Clock. The Clock Oscillator is a crystal-controlled multivibrator. The oscillator frequency is 4 MHz in instruments designed for 60 Hz line operation, and 3.333 MHz in units for 50 Hz operation. The oscillator output is divided by two before being applied to the Data Counter.

4-84. Data Counter.

4-85. The Data Counter is a hexadecade counter containing six decade counters, six 4-line latches, and output multiplexing. At the end of run-down, a Transfer pulse from the Transfer and Zero Detect logic transfers the count information in BCD form into the 4-line latches. Scan signals from the Display assembly cause the BCD count information to be transferred to the Display digit by digit, beginning with the least significant digit. The Data Counter accumulates clock pulses continuously until a Clear Data Counter signal is received from the Logic Output Decoder.

4-86. Buffers.

4-87. Inputs to the buffer amplifiers are two intermediate outputs from the Data Counter, Divide by 10,000 and Divide by 100,000. The outputs of these amplifiers are gated by the Select Hundred Thousand Counts signals, HSHC and LSHC, from Logic Storage. If HSHC is HIGH and LSHC is LOW, the Divide by 100,000 output is selected, and if HSHC is LOW and LSHC is HIGH, the Divide by 10,000 output is selected. The Buffer output is applied through an emitter follower to the Timing Counter.

4-88. Timing Counter.

4-89. The Timing Counter consists of a single D flip-flop and a 4-bit binary counter. Five binary square wave signals are produced in addition to the Timing Counter input signal. This input signal is not a symmetrical square wave, but is HIGH for 9,000 (or 90,000) counts and LOW for 1,000 (or 10,000) counts. These six timing signals go to the Qualifier Multiplexer, and are used to control run-up time, overload point, sample rate delay, and function delay.

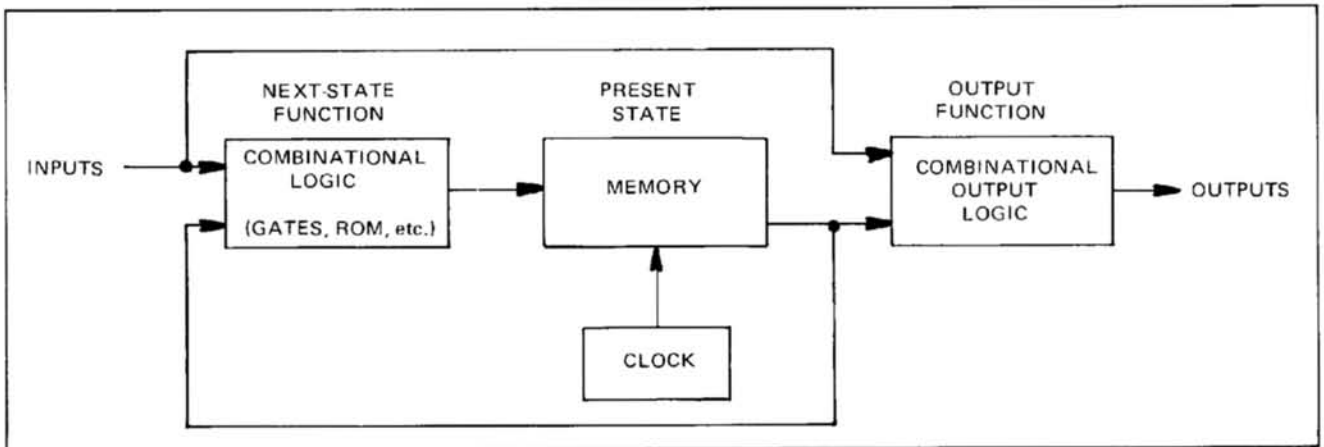

Figure 4-9. Typical State Machine Block Diagram.

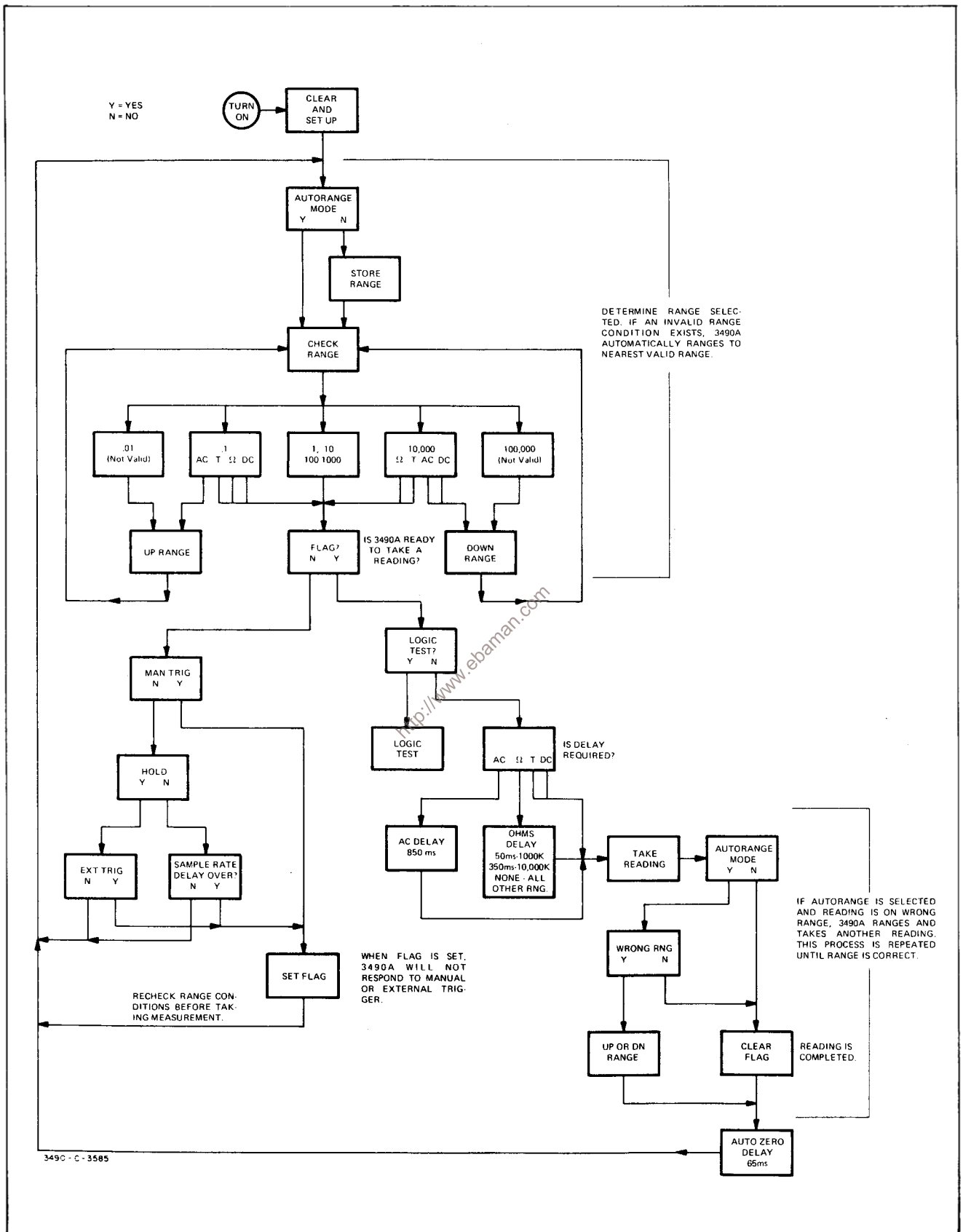

Figure 4-10. Block Diagram, Main Logic ASM Flow Chart.

4-90. Algorithmic State Machine.

4-91. The 3490A main logic circuits employ a logic system called an Algorithmic State Machine (ASM). Figure 4-9 shows a typical State Machine block diagram. The ASM outputs are determined by the "state" of the machine at a given instant, called the "present state." Certain outputs in the present state, along with one or more "qualifier" inputs, determine the "next state" of the ASM. For example, if the qualifier input is a certain timing signal, the Next State Function logic may wait until this qualifier reaches a predetermined level to change the state of the ASM. Each new state provides a different combination of outputs.

4-92. Figure 4-10 is a block diagram of the main logic ASM flow chart. This chart illustrates the process followed by the ASM in taking a normal measurement. Note that at many points, the path taken depends on the condition of a certain signal. This signal is the qualifier input to the ASM at that particular time.

4-93. State Clock. The input to the State Clock is the 4 MHz (or 3.333 MHz) output from the Clock Oscillator (Figure 4-8). This signal is divided by a 4-bit binary counter and a D flip-flop, so that the State Clock output has a period of 8 μ s (or 9.6 μ s). The two State Clock outputs, labeled HSCK and LSCK, are 180° out of phase, and are used for alternate synchronous clocking of input signals to the ASM storage. The State Clock output is also used in the Data Output and Remote Control circuits.

4-94. Read Only Memory. Figure 4-11 is a block diagram of the Main Logic Circuits. The 3490A logic uses a Read Only Memory. Seven of the memory inputs

in the "present" state are used, along with a "Qualifier" input, to determine the next state. Five other memory outputs are used to select the qualifier, as well as to initiate the other logic action. In addition, the Read Only Memory (ROM) also supplies an Output Enable signal to the Logic Output Decoder, a Memory Output signal to the Logic Storage flip-flops. Transfer Enable to the Transfer and Zero Detect gates, and a Close Electronic Switch signal to the Integrator.

4-95. Present State Storage. The Present State Storage consists of seven D flip-flops. The next state outputs from the ROM are clocked into the flip-flops by the State Clock L signal. The D flip-flop outputs are the present state. Together with the qualifier input, they determine the next state outputs of the ROM. The qualifier input is clocked into memory storage at the ROM input by the State Clock H signal 4 μ s later to prevent uncertainty in the ROM next state decision.

4-96. State Identification. Each state may be identified by a three-digit octal coded number determined by the levels of D flip-flop outputs YMA through YMG, shown in Figure 7-24. For example, in state 000, all seven outputs are LOW ("0"). If only YMA goes HIGH ("1"), the state is then 001. In the state where YMG = 1; YMF = 0; YME = 1; YMD = 1; YMC = 1; YMB = 1; YMA = 1 (1 011 111), the state identification number is 137. A total decimal number of 128 states are possible, with the highest state identification number being 177.

4-97. Qualifier Multiplexer. A block diagram of the Qualifier Multiplexer is shown in Figure 4-12. Qualifier Enable signals LMQA, LMQB, and LMQC from the ROM are inverted and used to select one output out of eight

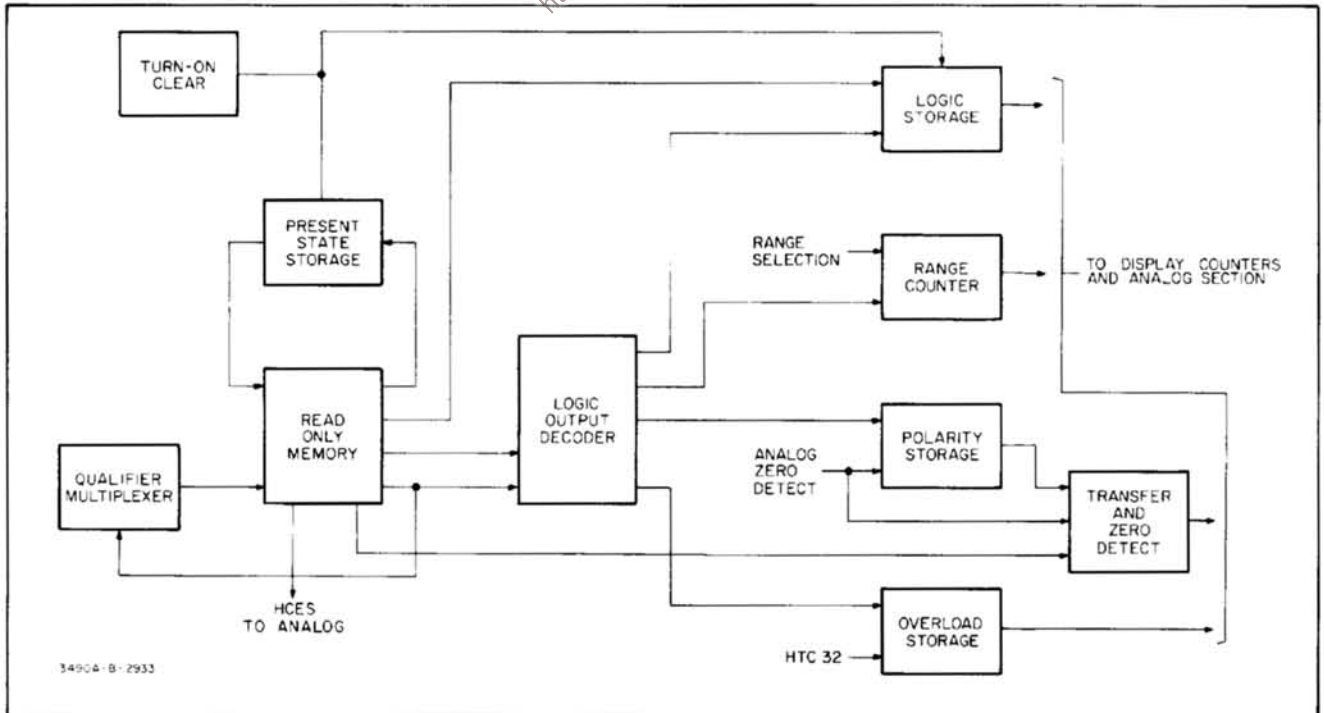

Figure 4-11. Block Diagram, Main Logic Circuits.

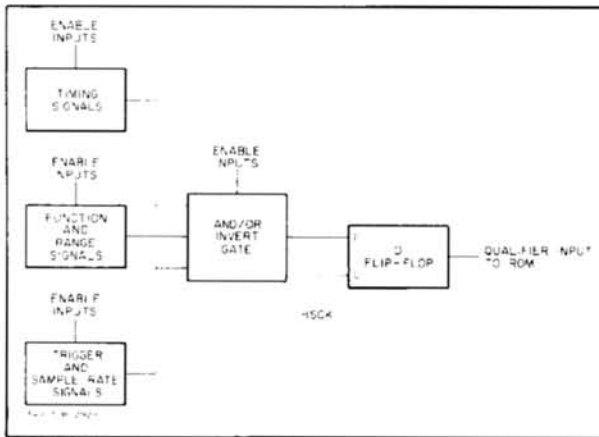

Figure 4-12. Block Diagram, Qualifier Multiplexer.

input signals to each of three 3-to-8 line decoders. These three outputs are applied simultaneously to the AND/OR Invert Gate. The other two Qualifier Enable signals, LMQD and LMQE, are inverted and both HIGH and LOW true signals are used at the AND/OR Invert Gate to select one of the three decoder outputs. The output from the Invert Gate is applied to a D flip-flop, which is clocked by State Clock signal HSCK, and whose output is the Qualifier Input to the ROM. This clock signal is 180° out of phase with State Clock LSCK which clocks the Present State Storage flip-flops. This prevents uncertainty in the ROM next state decision.

4-98. Logic Output Decoder. This 4-to-16 line decoder uses four inverted enable signals from ROM, HMQA-D, to select the proper output. In addition, the Output Enable signal from the ROM, and the State Clock signal LSCK must both be LOW to obtain an output from the decoder. All outputs from this decoder are LOW true, and are used to clock the Logic Storage flip-flops, to clear certain storage flip-flops, to clear the Data and Timing Counters, to operate the Range Counter, and to clock the Polarity and Overload storage flip-flops.

4-99. Logic Storage. The input level to the D inputs of the six Logic Storage flip-flops is determined by the inverted Memory Output signal from the ROM. Each flip-flop is clocked to change its output at a different time (or times) during the measurement sequence.

4-100. Main Timing Flip-Flops. Three Main Timing Bits are produced by Logic Storage flip-flops. All of these are used in controlling the DC Switching Logic, which determines inputs to and gain of the DC Amplifier. Main Timing Bit A is also used to drive the sample rate indicator. When Main Timing Bit B is LOW, it activates the Auto Zero circuits in the DC Amplifier and Integrator.

4-101. End of Reading Flip-Flop. The output of this flip-flop is normally HIGH, and goes LOW shortly after the Zero Detect of a measurement. If the instrument is in the autorange mode, the End of Reading signal

remains HIGH until after Zero Detect on the correct range. After going LOW, End of Reading goes HIGH at the end of the measurement sequence. The HIGH to LOW transition signals to the Data Output circuits that the information stored in the Data Counter is valid and allows the data to be transferred across guard before the Data Flag goes from "busy" to "ready."

4-102. Data Flag Flip-Flop. The Data Flag output from this flip-flop goes LOW at the beginning of a measurement and remains LOW until the reading cycle is completed. If autorange is selected, Data Flag remains LOW until a reading has been made on the correct range. This signal is inverted in both the Data Output and Remote circuits.

4-103. Select Divide by 100,000 Flip-Flop. The two outputs from this flip-flop are used to select either the divide by 100,000 or divide by 10,000 counts output from the Data Counter to the Timing Counter.

4-104. Turn-On Clear. The output of the Turn-On Clear circuit is LOW for approximately 100 ms after the instrument is turned on. This LOW signal clears the Main Timing B and C flip-flops and the Present State Storage flip-flops, to force the logic into the preferred state when the instrument is first turned on.

4-105. Input Polarity Storage.

4-106. The input to this D flip-flop is the inverted output of the Analog Zero Detect Amplifier in the Integrator circuits. The flip-flop is clocked at the end of run-up. If the 3490A input is positive, the flip-flop D input will be LOW at the end of run-up, and HIGH if the input is negative. Both outputs are used in the logic Zero Detect circuits. The output which goes to the Display and the DC Switching Logic is HIGH for + input and LOW for - input.

4-107. Transfer and Zero Detect.

4-108. The Transfer and Zero Detect circuits are shown in the upper right hand corner of Figure 7-30. Two outputs are derived from these circuits; a LOW true Transfer signal, and a HIGH true Zero Detect signal. These signals may be issued at end of run-down (when Integrator output reaches zero), at overload if reading is greater than 120% of range, or when a False Transfer signal is given during Logic Test. Transfer goes to the Data Counter to transfer the count into the six quad latch circuits in the counter. Zero Detect is one input to the Qualifier Multiplexer, indicating to the ROM that a measurement has been completed.

4-109. Overload. A Transfer Enable signal from the ROM goes HIGH at the start of run-down, and remains HIGH until after the Transfer signal goes LOW. This enable signal is applied to one input of each of three AND gates in the AND/OR Invert Gate. The other input to the two-input AND gate is connected to the Time

Count 32 line from the Timing Counter. This line goes HIGH at the overload point, 120 % of range. The output from this AND gate then goes HIGH to produce Transfer and Zero Detect commands.

4-110. Negative Input. If the 3490A input is negative, the Polarity Storage Q output to the next AND gate will be HIGH. Since Transfer Enable is already HIGH, when Analog Zero Detect goes HIGH at the end of run-down, Transfer and Zero Detect commands are given.

4-111. Positive Input. When the 3490A input is positive, the Polarity Storage \bar{Q} output to the other three-input AND gate is positive. Again, Transfer Enable is HIGH, so when Analog Zero Detect goes LOW at end of run-down, this signal is inverted and applied to the third input of the AND gate, resulting in Transfer and Zero Detect commands.

4-112. False Transfer. One input of a two-input AND gate is connected to +5 V, enabling the other input to control the output. When False Transfer goes LOW during Logic Test operation, Transfer and Zero Detect commands are issued.

4-113. Overload Storage.

4-114. When a Zero Detect command is issued, the Overload Storage D flip-flop is LOW, indicating the measurement is less than 120 % of range, the flip-flop

output will be LOW. If Time Count 32 is HIGH, indicating a measurement of greater than 120 % of range, the flip-flop output will be HIGH. This output goes to the Data Output circuits (Option 021), and to the Display. A HIGH Overload signal is inverted in the Display circuits to turn on the Overload annunciator.

4-115. DC SWITCHING LOGIC.

4-116. The DC Switching Logic uses range, function, and polarity information, together with the three main Time Bits to control all inputs to the DC Amplifier during both run-up and run-down. This includes input protection on the two lower dc Ranges, input attenuation on the two higher dc ranges, and the output of the AC Converter in ac measurements. The DC Amplifier gain is also selected by the DC Switching Logic. In addition, this circuit also enables the Ohms Converter during resistance measurements, and controls the reed relay at the input to the AC Converter for ac measurements. A Read Only Memory and three dual-input NAND gates make up the DC Switching Logic.

4-117. REFERENCE SUPPLIES.

4-118. Voltage Measurements.

4-119. Figure 4-13 is a simplified diagram of the Reference and Ratio circuits. An accurate and stable +10 V Reference from a voltage regulated power supply

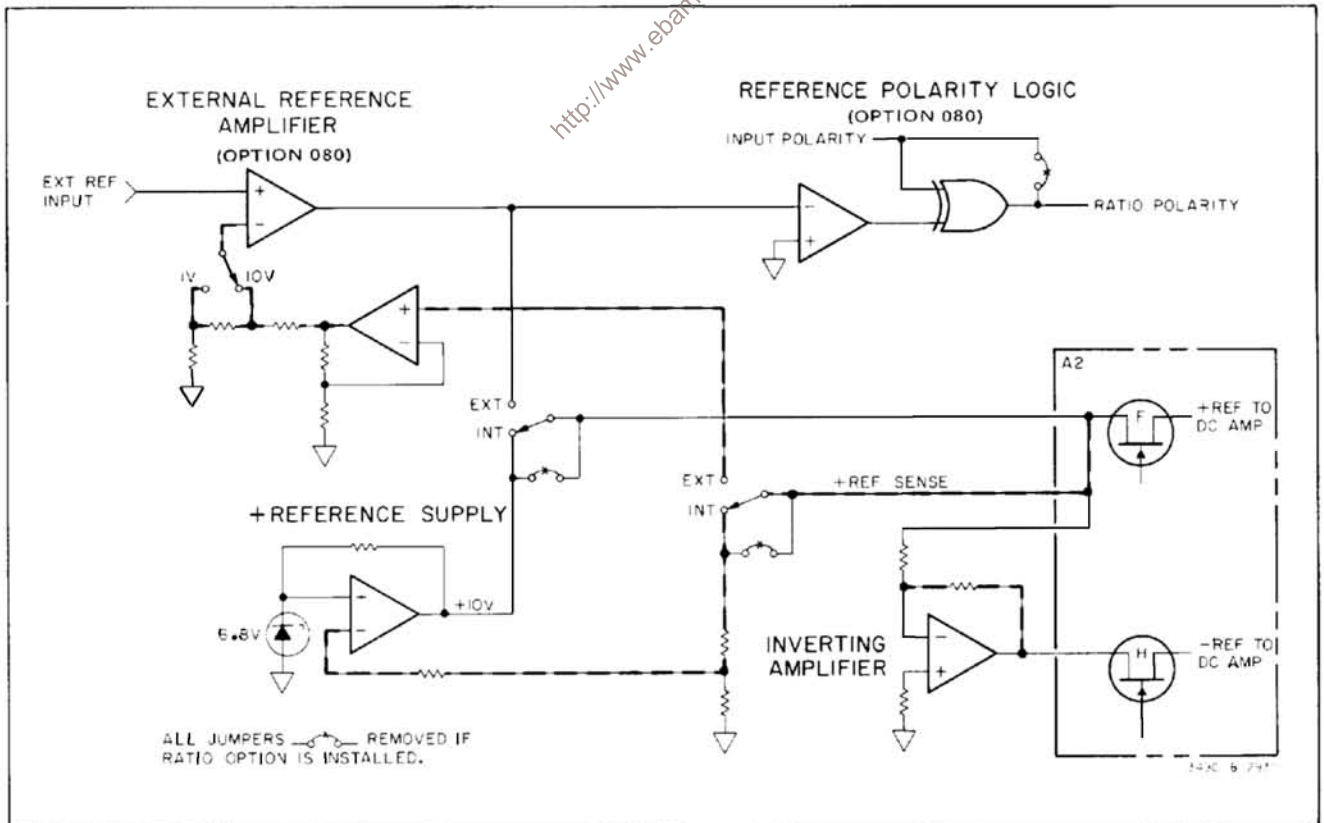

Figure 4-13. Simplified Diagram, Reference and Ratio Circuits.

circuit furnishes the positive reference which is used in negative dc voltage measurements. A feedback circuit which senses the reference voltage at the FET switch input to the DC Amplifier ensures the correct voltage at that point, even though there may be switch and connector contact resistance in the circuit. The input to the Inverting Amplifier, which supplies the - Reference, is also connected to the sense point.

4-120. Plus Reference. The differential amplifier of this supply is referenced to a zener diode which is in the emitter circuit of a feedback amplifier transistor. The diode and transistor are in the same package, for improved temperature stability. The amplifier gain is adjusted to provide an accurate + 10 V output.

4-121. Minus Reference. The - reference, used in ac and positive dc measurements, is supplied by an inverting amplifier whose input is the + 10 V reference. The gain of this amplifier is adjusted to provide an accurate - 10 V output.

4-122. Ratio Measurements (Option 080).

4-123. A 3490A equipped with Option 080 is capable of making dc-to-dc and ac-to-dc ratio measurements. The External Reference Amplifier has a gain of 10 when the Ratio switch is set to the 1 V range. This is necessary to make the external reference compatible with the reference switching logic, since in voltage measurements + and - 10 V references are used. Figure 4-14 is a simplified diagram of the external reference amplifier circuits.

4-124. External Reference Amplifier. A microcircuit operational amplifier, connected in the non-inverting

mode, is used as a buffer amplifier for the external reference input. The gain of this amplifier is selected by adjusting the output of the Feedback Amplifier. A third microcircuit amplifier provides current to compensate for bias current drawn by the input amplifier. The External Reference Amplifier input is clamped to approximately ± 14 V to protect against excessive input voltage up to ± 250 V. Greater input voltages may damage either the protection circuit or the Reference Amplifier. The amplifier output is limited to approximately ± 14 V for the protection of subsequent circuits.

4-125. Feedback Amplifier. An amplifier is used in the feedback circuit so that the External Reference Amplifier gain on the 10 V Ext. Ref. range can be adjusted slightly above or below unity as required. On the 1 V Ext. Ref. range, the feedback is attenuated to give the Reference Amplifier a gain of 10, because in ratio measurements, this reference is substituted for the 10 V internal reference.

4-126. Input Compensation Amplifier. Bias current at the input of the External Reference Amplifier could cause an offset voltage drop across the input protection resistor if this current were not compensated for by the Input Compensation Amplifier. Figure 4-15 shows how this is accomplished. The External Reference Amplifier maintains both its inputs at approximately the same voltage, so that the voltage at the inverting (feedback) input is essentially equal to the External Reference input. This voltage is connected to the non-inverting input of the input Compensation Amplifier, U2, which has a gain of 1. The output of U2, then, is essentially equal to the External Reference input voltage, and may be ± 0.1 V to ± 12 V. The amplifier offset is adjusted

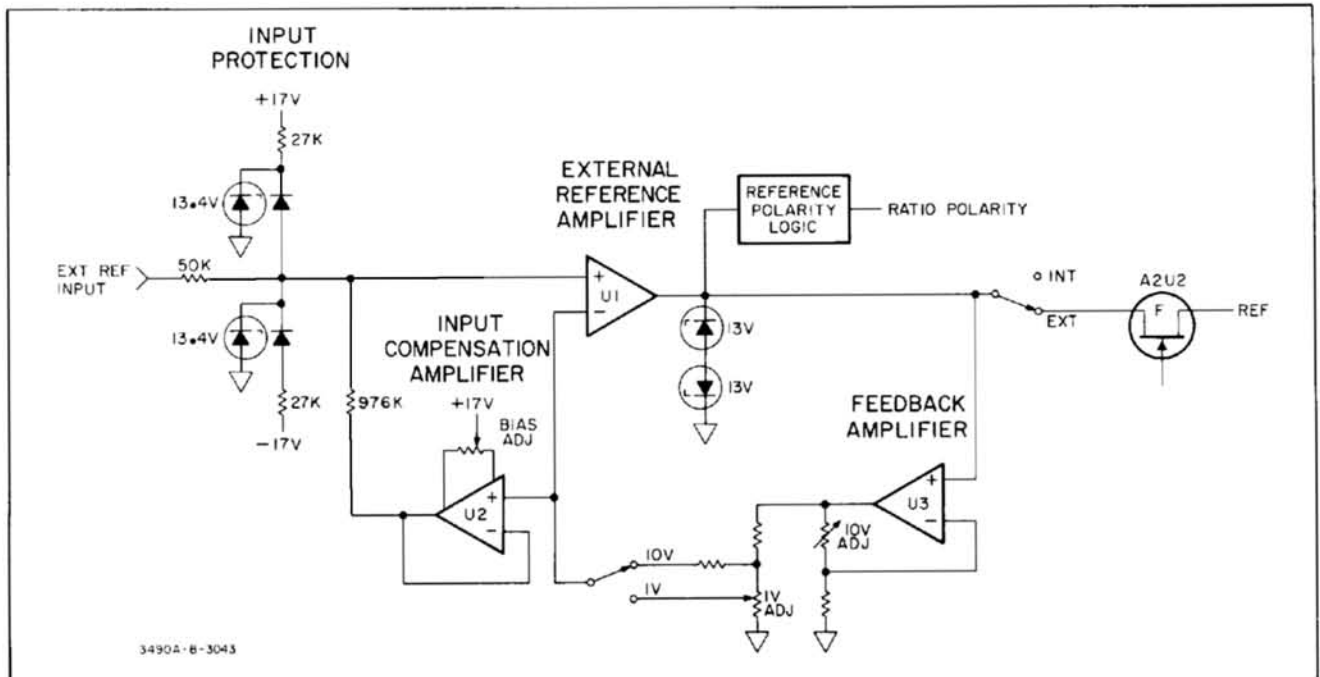

Figure 4-14. Simplified Diagram, External Reference Circuits.

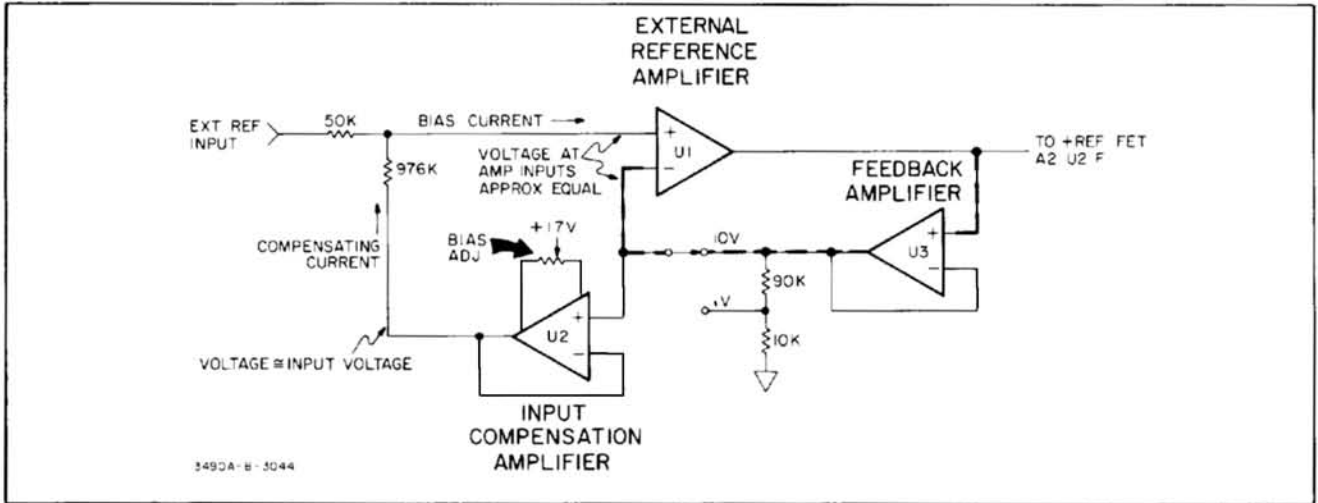

Figure 4-15. Input Bias Compensation.

with the Bias Adjustment so that the compensating current is equal to the bias current at the External Reference Amplifier input.

4-127. Reference Polarity Logic. In the dual-slope integration method of measurement, the polarity of the reference voltage used for run-down (integrator discharge) must be opposite the polarity of the input voltage. The 3490A automatically selects the correct reference polarity whether the External Reference input is positive or negative. Since the external reference voltage in ratio measurements replaces the positive internal reference, the logic signal which selects the run-down reference polarity must be inverted when the external reference is negative. Figure 4-16 shows how this is accomplished. The External Reference Amplifier output is inverted and applied to one input of an Exclusive OR Gate. The other input of this gate is connected to the stored Input Polarity signal from the Logic circuits. The Exclusive OR Gate output is HIGH if one and only one input is HIGH. If both inputs are either HIGH or LOW, the output is LOW. Because the output of the AC Converter is positive, a negative reference is selected in all ac measurements. The front panel display polarity symbol is + if the input signal and external reference are of the same polarity, and - if they are of opposite polarity. No polarity symbol is displayed

for ac/dc ratio measurements. Table 4-2 shows the reference polarity required for the various combinations of input and reference voltages.

4-128. FRONT PANEL SWITCHING.

4-129. Range, Function, and Sample Rate delay are controlled by HIGH true BCD logic signals from the front panel switches. HOLD and MAN Trigger signals are LOW true. If the 3490A has a Remote Control option, Range and Function information are routed through the Remote Control circuits so that, if desired, these operations may be controlled remotely. Unless Auto-range is selected, the Range information is stored by the Range Counter in the Logic circuits.

4-130. POWER SUPPLIES.

4-131. Figure 4-17 is a block diagram of the inguard power supplies. Regulated supplies of ± 30 V, ± 17 V, and ± 5 V provide power to the inguard circuits of the 3490A. An outguard +5 V supply is a part of Options 020, 021 and 022. The +17 V supply is regulated by a microcircuit regulator, and its output is accurately adjusted. All the other inguard regulator circuits depend directly or indirectly upon the +17 V supply, as indicated in the block diagram of Figure 4-17, since +17

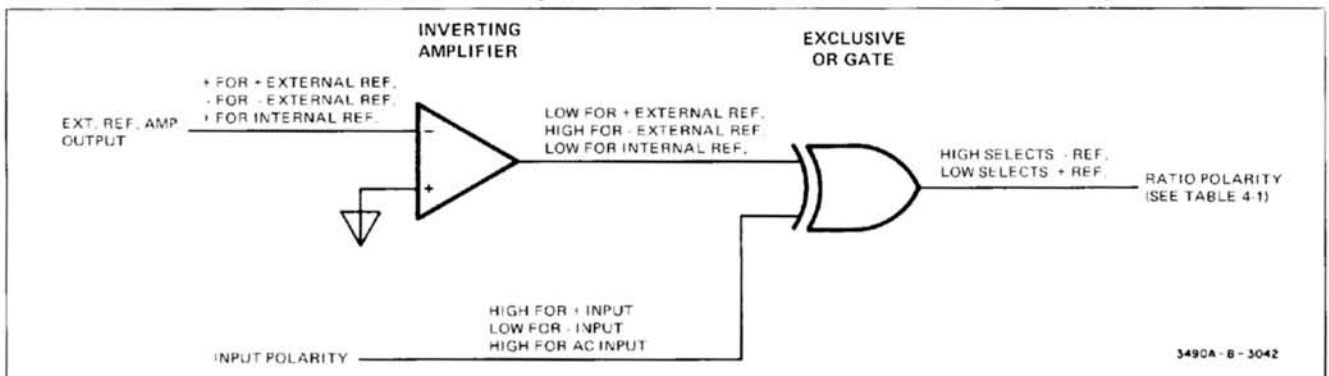

Figure 4-16. Reference Polarity Logic.

Table 4-2. Polarity in Ratio Measurements.

External Reference Input	Input Signal	Ratio Polarity Signal	Displayed Polarity	Measurement Run-down	
				Reference Required	Amplifier Output Used
+	+	HIGH	+	-	Invert. Amp.
+	-	LOW	-	+	Ext. Ref. Amp.
-	+	LOW	-	-	Ext. Ref. Amp.
-	-	HIGH	+	+	Invert. Amp.
+	ac	HIGH	none	-	Invert. Amp.
-	ac	LOW	none	-	Ext. Ref. Amp.

volts is used as a reference for the +30 V, +5 V and -17 V regulators. The -30 V regulator uses -17 V as a reference. U102 in the -17 V supply is operated off raw supply thru CR123 until the -30 V supply comes up after turn-on. It is then operated off -30 V thru CR122. The -5 V supply is zener regulated from the -17 V supply. All supplies except the -5 V supply are voltage regulated and current limited for protection. The output of each supply is limited by a zener diode to protect the circuits it supplies.

Table 4-3. Analog Tests.

Test No.	Run-Up		Run-Down	
	DC Amp. Input	DC Amp. Gain	DC Amp. Input	DC Amp. Gain
2	Ground	x 1	+ Ref/- Ref	x 1
3	+ Ref/- Ref	x 1	- Ref/+ Ref	x 1
4	+ Ref	x 1	Input x 1	x 1
5	Ground	x 100	+ Ref/- Ref	x 1
6	Input x 0.01	x 100	+ Ref	x 1
7	Ω Ref	x 10	+ Ref	x 1

4-132. SELF-TEST FUNCTION.

4-133. Seven tests, which may be selected by front panel switch settings or by optional remote control, provide internal checks on the operation of many of the 3490A circuits. Test No. 1 checks approximately 70 % of the logic circuits, and the other six check analog circuits as explained in the following paragraphs and in Table 4-3.

4-134. Logic Test, No. 1.

4-135. A series of ten readings, shown below, provide visible indication as to whether the display and certain logic circuits are operating correctly. Note that the instrument autoranges one step for each reading, upranging through all ranges, then downranging through all ranges. Note also that the numerical display changes for each range. In logic test, two factors determine the

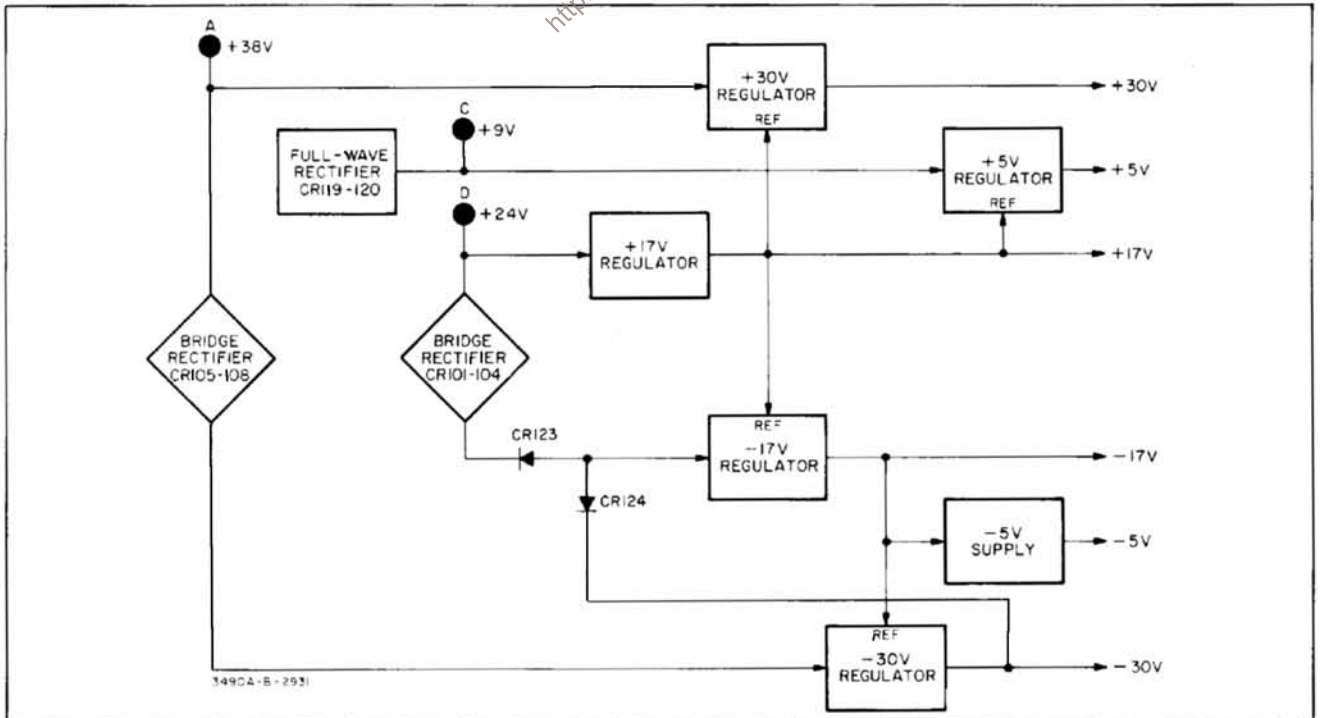

Figure 4-17. Power Supply Block Diagram.

numerical display; the length of time that the Data Counter is allowed to count, and the Data Counter output to the Timing Counter (divide by 10,000 or divide by 100,000 counts). In each range, one of six Timing Counter outputs determines the length of the count, and consequently, the most significant digit. The position of the most significant digit is the result of the Data Counter output selected. If Main Timing Bit B is HIGH, the divide by 100,000 output is selected, and if B is LOW, the divide by 10,000 output is used. If Main Timing Bit C is HIGH, the instrument upranges, and if C is LOW, it downranges. Both timing bits are set HIGH when the instrument reaches the lowest range, and set LOW when the highest range is reached.

+ 080.024
 + 04.0024
 + 0.20024
 + .010024
 + 0.09032
 + 10.0024
 + 200.024
 + 4000.24
 + 80002.4
 + 6000.xx OL

4-136. During the last measurement listed above, the Transfer signal is switched on for 8 counts and off for 8 counts during the entire counting period, which lasts for 1,600,000 + counts. Because of the counting frequency, nearly all dots in the display appear to be on during this period. The 1 (in 1,600,000) is lost because the display does not provide a seventh digit. In all except the last reading, the two least significant digits are predictable because of known transition times during the reading.

4-137. 10 V Range Zero, Test No. 2.

4-138. Test No. 2 selects a DC Amplifier gain of 1 for both run-up and run-down, which is the 10 V range configuration. During run-up, the amplifier input is grounded through the Input Short FET switch (C in Figure 4-4). Either the + or - Reference is used for run-down just as in a normal dc measurement with zero input. If the amplifier and its auto zero circuits are operating correctly, the display should be zero.

4-139. Turnover Error, Test No. 3.

4-140. Test No. 3 checks for turnover errors, such as differences in value between the + and - Reference voltages, or amplifier offsets which result in differences between positive and negative readings with inputs of the same absolute value. For this test, the instrument uses the + Ref for run-up and the - Ref for run-down in one measurement, and - Ref for run-up and + Ref for run-down in the following measurement. The stored polarity of the run-up voltage in one measurement is used to select the run-up voltage of the opposite polarity for the next measurement. In the Adjustment Procedures, after the + Reference has been adjusted, Test No. 3 is used to adjust the - Reference.

4-141. + Reference Check, Test No. 4.

4-142. This test compares the voltage at the + Ref FET switch (F in Figure 4-4) to a precise input voltage. The voltage through the + Ref FET is used for run-up, and the input voltage is used for run-down. If the instrument does not have the ratio option, or if the RATIO switch is set to INT REF, this checks the internal + Reference voltage. With the RATIO switch set to EXT and the EXT REF input terminals shorted, Test No. 4 can be used in adjusting the External Reference Amplifier zero for both the 1 V and 10 V reference ranges.

4-143. 0.1 V Range Zero, Test No. 5.

4-144. The 0.1 V Range is simulated for this test by setting the DC Amplifier gain at x 100 for run-up, and using the normal reference voltages for run-down. The amplifier input is grounded through the Input Short FET during run-up, and either the + or - Reference is used for run-down as in a normal voltage measurement. Test No. 5 checks operation of the auto zero circuits in the DC Amplifier.

4-145. x .01 Atten., x 100 Gain, Test No. 6.

4-146. In Test No. 6, a precise -10 V input voltage is first divided by 100 in the attenuator, then amplified by 100 in the DC Amplifier. The + Reference is used for run-down as in a normal measurement. An incorrect reading in this test could indicate error in the attenuation, the DC Amplifier gain adjustment, or a thermal offset. Test No. 6 is used in the Adjustment Procedures for adjusting the x 100 gain.

4-147. Ohms Reference, Test No. 7.

4-148. In Test No. 7, the signal at the Ω Ref FET switch (G in Figure 4-4) is amplified by 10 and compared to the +10 V Ref. The Ω Signal input terminals must be shorted to close the feedback loop of the Ω current source amplifier, thus generating the Reference voltage across the reference resistor (see Figure 4-7). Because a precise voltage is not required for the Ω Reference, the tolerance for this test reading is ± 7000 counts. A correct reading verifies proper operation of most of the Ohms Converter circuits.

4-149. BCD REMOTE EXPAND OPTION 020 (Figure 7-31).

4-150. Outguard Power Supply.

4-151. A microcircuit regulator supplies a voltage of approximately +5.3 V to the outguard Data Output, Remote, Trigger and Sample/Hold Trigger circuits. This voltage is shown on the schematic diagrams as +5 VI, and is isolated from all inguard circuits. The outguard ground is also isolated from the inguard common circuits and from chassis (earth) ground, and may be floated a maximum of 40 V above chassis ground.

4-152. Isolated Trigger and Hold.

4-153. External Encode and Hold are both LOW true signals. They are inverted and applied through emitter followers to photo-isolators, consisting of a light-emitting diode which drives a photosensitive transistor. Consequently, there is no electrical connection between outguard and inguard circuits.

4-154. Sample/Hold Trigger Circuits.

4-155. **Sample/Hold Trigger.** When this input goes from HIGH to LOW for a pulse width of at least 30 nanoseconds, it signals the Sample/Hold circuits (Option 040) to "hold". This pulse is inverted twice and applied to an isolation transformer, which couples the trigger signal to the inguard Sample/Hold circuits. The Sample/Hold Trigger input connection is direct coupled, and if the connection (rear panel J7 pin 9) is left open, +5 V is present at that pin. This trigger will not initiate a reading unless the Stretched Pulse Output is connected externally to External Encode.

4-156. **AC Trigger.** This input may be any pulse having a negative-going leading edge of 2 to 15 volts and a width of at least 30 nanoseconds. This pulse is capacitively coupled to the isolation transformer to trigger the Sample/Hold circuits.

4-157. **Stretched Pulse Out.** This output changes from HIGH to LOW for at least 240 microseconds for each Sample/Hold or AC Trigger input. Stretched Pulse Out may be connected to External Encode to initiate a measurement simultaneously with the Sample/Hold trigger.

4-158. DATA OUTPUT OPTION 021.

4-159. The Data Output connections at the rear panel are isolated from the internal circuits of the 3490A. Power for the outguard circuits is supplied by the outguard +5 V power supply. Outguard ground is isolated from inguard circuit common and chassis (earth) ground, and may be floated up to 40 V above chassis. Figure 7-32 is a diagram of the Data Output circuits.

4-160. Data Multiplexers.

4-161. Three multiplexers, each having 8 input lines and 4 output lines, are used to transfer the Data Output information across the guard to four eight-bit shift registers. An "output select" (S_0) connection to each multiplexer selects one set of four inputs if the S_0 input is HIGH, and the other set of four inputs if S_0 is LOW. The outputs from two multiplexers are applied to the inputs of the third, or "master" multiplexer. The outputs of the master multiplexer are enabled for only the eight periods of time necessary to transfer all the Data Output information, as shown in Figure 4-18. The Sequential Logic determines the time and sequence of information transfer.

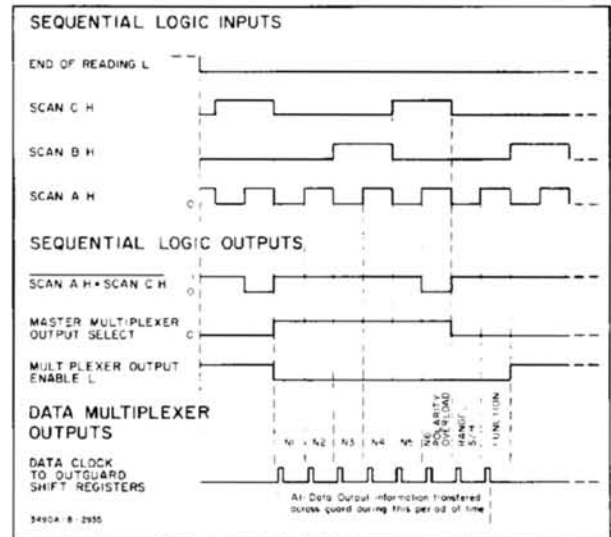

Figure 4-18. Data Output Timing Diagram (Option 021).

4-162. Data Output Sequential Logic.

4-163. Figure 4-18 shows the timing sequence of the sequential Logic inputs and outputs. The Logic is enabled when the End of Reading signal goes LOW at the completion of a measurement. The three scan signals which control the outputs from the Data Counter operate the Logic to correlate the multiplexer outputs with the outputs from the Data Counter. The Sequential Logic consists basically of three JK flip-flops. The scan signal inputs to the flip-flops are gated to obtain the desired output pattern.

4-164. Data Clock.

4-165. A Frequency Doubler is used so that a clock pulse is issued for each transition of the Scan A signal. These pulses are delayed slightly before being applied to the outguard Shift Registers, to allow time for the multiplexer outputs to reach the proper state.

4-166. Isolation Assembly.

4-167. Each signal is transferred across guard through a photoisolator, which consists of a light-emitting diode driving a photosensitive transistor. Consequently, no electrical connection is made between the inguard and outguard circuits.

4-168. Shift Registers.

4-169. Four 8-bit Shift Registers are used, providing the capability of 32 parallel output lines. Each time a Data Clock pulse is received, the information in the shift register shifts one position and a new input is accepted. A dual-input Exclusive OR gate in each of the shift register input lines determines whether the coded Data Output information is HIGH true or LOW true. The operation of these gates is such that if one and only one input is HIGH the output is HIGH. If both inputs are

either HIGH or LOW, the output is LOW. The HIGH/LOW switch on the Outguard Data Output Assembly controls one input to each gate. When the HIGH/LOW switch is set to HIGH, one input to each gate is always LOW; consequently, the output will be the same logic level as the other input. When the switch is set to LOW, one gate input is always HIGH. Consequently, if the other input is also HIGH, the output will be LOW, and if the input is LOW, the output will be HIGH.

4-170. Data Flag.

4-171. The Data Flag output signal goes HIGH at the beginning of a measurement and LOW after a reading sequence is completed. The HIGH to LOW transition indicates that the Data Output information is ready. This transition constitutes a Print Command to a digital recorder. If the instrument is operating in the autorange mode, Data Flag remains HIGH until a reading on the correct range has been completed.

4-172. Printer Hold.

4-173. A HIGH signal from a digital recorder, indicating that the recorder is not ready for an input, is inverted and connected to the 3490A Hold line. This prevents automatic sampling until the Printer Hold signal returns to LOW. A slide switch on the Outguard Data Output printed circuit board permits disabling of the Printer Hold line. If the switch is in the IN position and the Printer Hold line is left open, the inverting transistor output may go LOW, resulting in a "Hold" condition.

4-174. REMOTE CONTROL OPTION 022.

4-175. The Remote Control Option permits remote control of range, function, autorange selection, and Sample/Hold operation. All connections at the rear panel Remote Input connector are isolated from the 3490A internal circuits. Power to the outguard circuits is supplied by the +5 V outguard power supply. Outguard ground is isolated from inguard circuit common and from chassis (earth) ground, and may be floated up to 40 V above chassis. Figure 7-33 is a diagram of the Remote Control circuits.

4-176. Circuit Isolation.

4-177. A photo-isolator, consisting of a light-emitting diode which drives a photosensitive transistor, is used to carry each signal across guard. Consequently, there is no electrical connection between inguard and outguard circuits.

4-178. Remote Enable.

4-179. When the Remote Enable input is held LOW continuously, this information is carried across the guard to the Local/Remote Flip-Flop. Control of the flip-flop is provided by two NAND gates. A LOW Remote Enable signal results in a LOW signal to one input of one of the

gates, and a HIGH signal at one input of the other gate. The Remote Enable signal is gated so that the Local/Remote Flip-Flop cannot be changed while remote program information is being transferred across guard.

4-180. Outguard Multiplexer.

4-181. This dual 4-to-1 line multiplexer accepts 8 bits of range and function information. Then, when a Program Execute command is given, this information is transferred serially, two bits at a time, to the two inguard Shift Registers. The Scan A signal is used to select the multiplexer outputs. Scan A is applied to one output selection line, and Scan A divided by 2 is applied to the other line. Figure 4-19 shows the multiplexer output sequence.

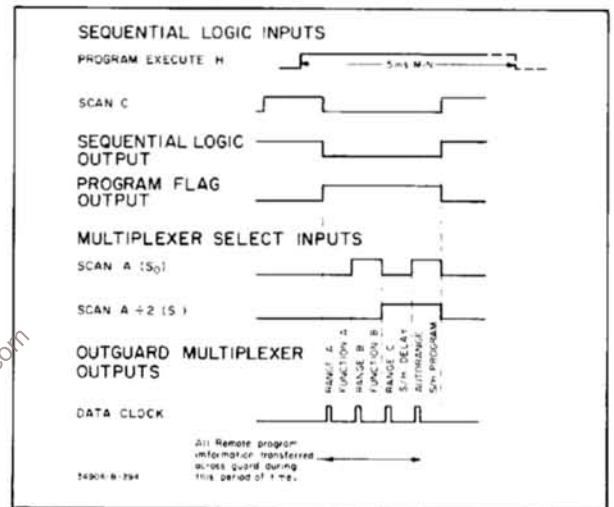

Figure 4-19. Remote Control Timing Diagram (Option 022).

4-182. Remote Sequential Logic.

4-183. The Sequential Logic is enabled by application of a Program Execute command, which must go from HIGH to LOW for a minimum of 5 milliseconds. This signal is inverted and applied to the Logic. The next time the Scan C signal goes LOW after receipt of a Program Execute command, the Logic output also goes LOW and remains LOW until Scan C goes HIGH. Inputs to the JK flip-flops of the Logic are gated so that only one LOW output is present for each Program Execute command, regardless of its pulse width above 5 ms. While the Logic output is LOW, it enables the Data Clock signal and the Scan A signal, so program information may be transferred into the shift registers. Also, when another Logic output signal is LOW, it disables a gate in the Remote Enable signal line so that the Local/Remote selection cannot be changed during the Program Execute procedure.

4-184. Program Flag.

4-185. The Program Flag signal goes HIGH to indicate that remote program information is being accepted, and

returns to LOW to indicate programming is complete. While the signal is HIGH, it enables gates in both inguard and outguard circuits to allow transfer of information. At the same time, an output from the Sequential Logic disables the State Clock signal to the Local/Remote Flip-Flop, to prevent the clock from changing the flip-flop during a remote programming period. When the Program Flag signal is LOW, it disables the Scan A divide-by-two flip-flop.

4-186. Data Clock.

4-187. A Frequency Doubler is used so that a clock pulse is issued for each transition of the Scan A signal. These clock pulses are delayed slightly before being applied to the Shift Registers, to allow time for the program information to reach the proper state.

4-188. Shift Registers.

4-189. One-half of the dual 4-bit shift register micro-circuit carries the range information, and the other contains function information. Each Data Clock pulse shifts the information bits in the registers one position and inserts a new bit. The shift register outputs are applied to two multiplexers.

4-190. Local/Remote Multiplexers.

4-191. The four outputs from each of these multiplexers may be either of two sets of four inputs. One set of four inputs is the remote program information bits, and the other set is the corresponding information from the front panel switches. The logic level of the "output select" connection to the multiplexer selects either the local or remote program information. The "output select" signal is the output of the Local/Remote Flip-Flop. The multiplexer outputs are the range and function information used in the logic circuits.

4-192. Local/Remote Flip-Flop.

4-193. The Local/Remote Flip-Flop provides the "output select" signal to the Local/Remote Multiplexers. A NOR gate is used to gate the State Clock input to the flip-flop. When the 3490A is turned on, the Turn-on L signal from the logic circuits sets the Local/Remote Flip-Flop to the Local state. When the Remote Enable line at the rear panel connector is held LOW, a LOW signal is applied to the D input of the flip-flop. A HIGH State Clock pulse then sets the Q output LOW. This LOW signal to the multiplexers selects the remote program information. An inverter connected to the other flip-flop output drives the Remote annunciator in the display.

4-194. Data Flag.

4-195. The Data Flag output signal goes HIGH at the beginning of a measurement and LOW to indicate the reading sequence has been completed. If the instrument

is operating in the autorange mode, Data Flag remains HIGH until a reading on the correct range has been completed.

4-196. HEWLETT-PACKARD INTERFACE BUS I/O (OPTION 030).

4-197. The Hewlett-Packard Interface Bus I/O option permits the Model 3490A to operate on a single data/control bus with several other instruments. The ASCII code, used in this system, is an eight-bit 4-2-1 octal code, parallel bit, serial character. The 3490A I/O has a talk address and a listen address, which allows the controlling instrument to instruct the 3490A to output measurement data or to receive programming information. Since each instrument on the bus may have its own distinct address codes, a single controller is able to instruct or receive data from each one individually. The 3490A HP-IB option is compatible with the -hp-9800 series calculators.

4-198. HP-IB System.

4-199. A typical bus system is shown in Figure 4-20. A total of 15 instruments may be connected in parallel to the bus. Each instrument on the bus is assigned an address (or addresses) so that it can be selected individually by the controller. This enables the controller to determine which instruments will be communicating on the bus at any given time. An instrument will have a listen address if it can receive data, a talk address if it can output data, or both a listen and a talk address if it can both receive and transmit data. For example, the listen address for the 3490A is normally the ASCII code character 6, and the normal talk address is V, assigned as shown in Paragraph 3-104. and Table 3-6.

4-200. A principal advantage of the bus system is that both remote programming and data output are done on

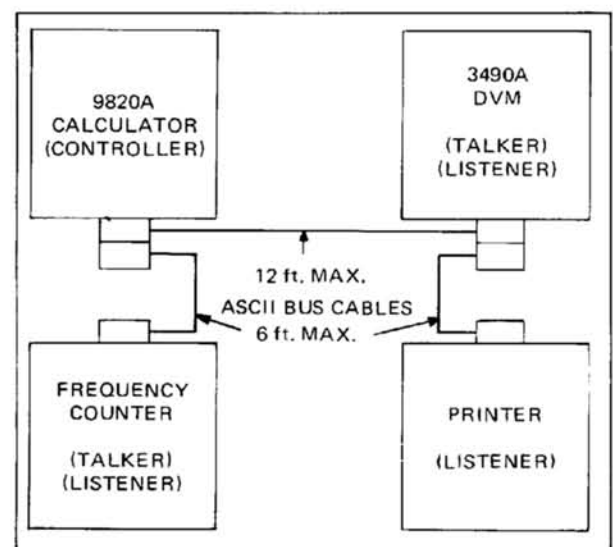

Figure 4-20. Typical Bus System.

the same data lines. For this reason a standard cable (which may be various lengths) is used to connect each instrument to the bus. The cable contains eight data lines and seven control lines.

4-201. Basic Theory of HP-IB I/O Circuits.

4-202. The 3490A HP-IB circuits employ two separate logic systems called Algorithmic State Machines (ASM). A brief explanation of Algorithmic State Machine is given in Paragraph 4-90. One ASM is inside the instrument guard (Inguard State Machine) and the other is outside the guard (Outguard State Machine). Each system must accept, store, and output information, providing a two-way communication link between the 3490A internal logic circuits and the other bus system instruments. The two State Machines are timed by separate free-running clocks; consequently, communication between the two machines is asynchronous. Figure 7-36 is a block diagram of the HP-IB I/O circuits. Table 3-5 lists the bus signal mnemonics.

4-203. Information is transferred across guard from one ASM to the other by means of photo-transistors, so that there is no electrical contact between inguard and outguard circuits. This allows the inguard and outguard circuits to operate on different ground systems at different potentials. The outguard ASM receives and interprets information from the controller. It then responds to the controller, and transfers the necessary information across guard to the inguard ASM, which programs the 3490A logic circuits. When the instrument is addressed to talk, the measurement output data is transferred across guard one digit or character at a time. Data is then placed on the bus data lines DIO1 through DIO7 one character at a time in the sequence shown in Paragraph 3-126. The timing of the data output is controlled by the three "handshake" signals described in Paragraphs 3-94 through 3-97.

4-204. HP-IB System Operation.

4-205. **Reset.** When power is first applied to the 3490A, the Reset circuit output is LOW for approximately 100 ms. This sets the inguard ASM to the "zero" state, and sets the range and function circuits to the front panel settings. It also clears the Sample/Hold and Remote storage flip-flops and the trigger mode, causing all programming to conform to the front panel settings. The outguard ASM circuits then check to see if the 3490A logic circuits indicate that the instrument is in remote control. If not, the instrument continues to be controlled from the front panel.

4-206. **Local Control.** In local control, the I/O circuits accept and store range and function information from the front panel. Sample Rate and Sample/Hold (optional) are controlled from the front panel. This information may be updated at any time by changing the control settings. If the Sample Rate control is set to HOLD, the

3490A may be triggered through the rear panel Trigger connector. If addressed to talk, the 3490A will output measurement data in accordance with normal bus operation.

4-207. **Address to Listen.** When the Outguard State Machine senses that the ATN line is LOW, it waits for DAV to go LOW indicating that the data information is valid. When DAV is LOW, data lines DIO5 through DIO1 are compared to the 3490A address bits. If they match, DIO7 is checked to determine if the address is to talk or to listen. If DIO7 is HIGH, the 3490A is addressed to listen. It then checks REN to see if it is LOW. If so, the internal RMT line is set LOW and this information is transferred across guard and the Inguard State Machine sets the 3490A to remote control, disabling the front panel range, function, and Sample/Hold controls. As soon as the address data and the REN line have been checked, the NDAC output is allowed to go HIGH, indicating that the data has been accepted.

4-208. **Remote Programming.** After the 3490A has been instructed to listen and placed in remote control, the controller sets ATN HIGH so that the 3490A can receive remote program data. This data is placed on the seven data lines DIO1-7 by the controller, one character at a time. After each character is placed on the data lines, the controller sets DAV to LOW, indicating to the 3490A Outguard State Machine that this data is ready. The Outguard State Machine checks to see if the data is valid for the 3490A and then transfers the data across guard to the Inguard State Machine. It also sets the NDAC line HIGH and NRFD LOW to indicate that the data has been accepted and is being processed. The Inguard State Machine then interprets the data and takes appropriate action. For example, if the character received is the alpha identifier R, the inguard circuits are set so that the next character (if it is a digit) is routed to the range storage circuit. (See Paragraph 3-106 for the remote programming sequence.) After a data character has been processed, NRFD is allowed to go HIGH, indicating to the controller that the 3490A is ready for new data.

4-209. When programming is completed, the controller must send the ASCII code character E, after which it may address the 3490A to talk or it may address any other unit on the bus to listen or talk. The character E indicates to the 3490A that the programming is ended. The 3490A then will not accept any more data until after ATN has again been set LOW and the 3490A listen address sent.

4-210. **Address to Talk.** When the 3490A is addressed to talk, it outputs the measurement data in the format shown in Paragraph 3-126. The output sequence is controlled by the Inguard State Machine through a multiplexer and a storage unit. As each output data character is transferred across guard, the outguard circuits place this character on the data lines and set DAV to LOW, indicating to the listener that valid data is available. When the listener sets NDAC HIGH, indicating

that the data has been accepted, the Outguard ASM signals to the Inguard ASM that new data may be transferred across guard. The output of the six digits of measurement magnitude is timed by the same scan signals (HSA, HSB, HSC) that control the 3490A display.

4-211. Talk Only. When the rear panel slide switch is set to the TALK ONLY position, the 3490A may be operated with a printer without the use of a controller. This switch sets the internal Talk Only line LOW, enabling the I/O circuits to output data after each measurement. Operation of the 3490A is programmed by the front panel controls.

4-212. SAMPLE/HOLD OPTION 040 or 045.

4-213. When the Sample/Hold option is installed in the 3490A, it occupies a position between the DC Input Amplifier and the Analog-to-Digital conversion circuits as illustrated in Figure 4-21. Because Sample/Hold follows the Input Amplifier, it is limited by that amplifier's characteristics. Either of two modes of operation may be used; Acquire/Hold (delayed trigger), or Track/Hold (non-delayed).

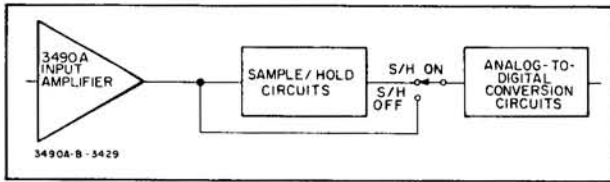

Figure 4-21. Sample/Hold Circuit Position.

4-214. Track/Hold Mode.

4-215. The Track/Hold Mode is useful in determining the value of a varying input voltage at a specific time.

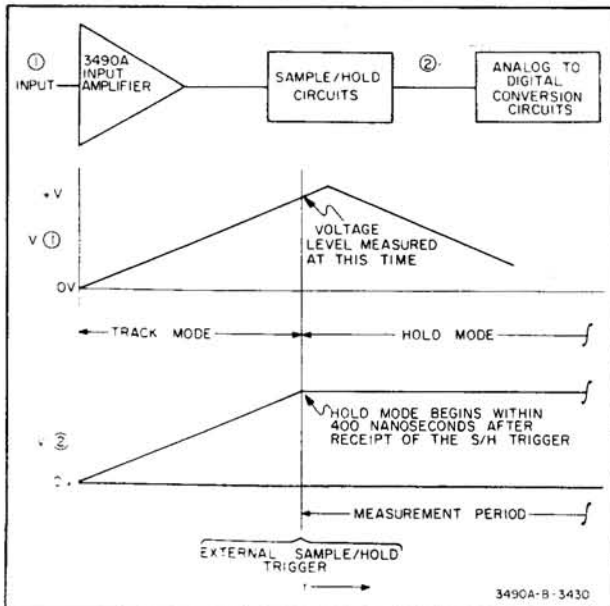

Figure 4-22. Waveforms Illustrating Track/Hold Mode.

measurement, the Sample/Hold amplifiers are again allowed to track the input signal.

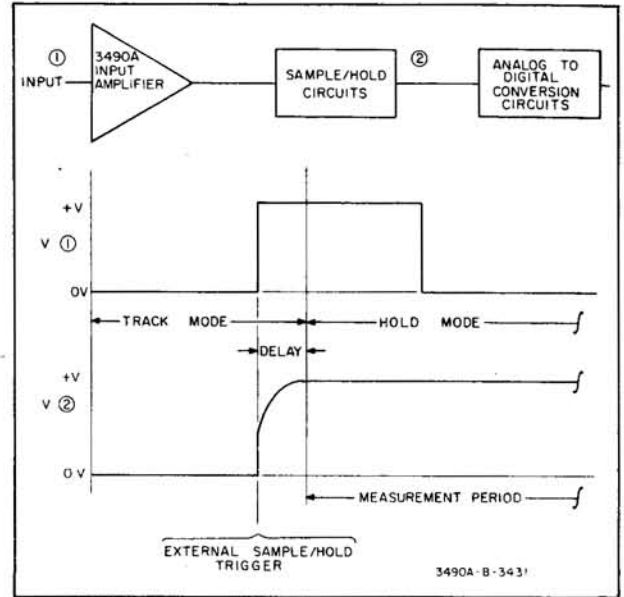

Figure 4-23. Waveforms Illustrating Acquire/Hold Mode.

4-216. Acquire/Hold Mode.

4-217. Acquire/Hold operation is essentially the same as Track/Hold operation, except that a delay is added between receipt of an external Sample/Hold Trigger command and the time the Hold Mode begins, as shown in Figure 4-23. This delay permits the DC Input and Sample/Hold amplifiers to respond fully to a step input voltage before holding and taking a measurement, making it possible to apply a Sample/Hold Trigger command simultaneously with a step input voltage. The length of the delay is dependent upon the range selected, as shown in Table 4-4.

Table 4-4. Acquire/Hold Delay.

Range	Delay	
	Option 050	Option 060
1 V	615.0 μ s \pm 400 ns	512.6 μ s \pm 400 ns
10 V	154.0 μ s \pm 400 ns	128.4 μ s \pm 400 ns
100 V	615.0 μ s \pm 400 ns	512.6 μ s \pm 400 ns
1000 V	154.0 μ s \pm 400 ns	128.4 μ s \pm 400 ns

4-218. Sample/Hold Measurement Sequence.

4-219. Figure 4-31 shows a simplified diagram of the Sample/Hold circuits and describes the measurement sequence. Sample/Hold Circuit A can respond quickly to a change in voltage at point 2. However, this circuit cannot hold a fixed level long enough for a complete measurement. Sample/Hold Circuit B cannot respond as quickly as A, but can hold a fixed level long enough for a complete measurement. In a Sample/Hold measurement, the voltage is sampled by Circuit A, then held by A until Circuit B has time to respond. Then the voltage is held by B while the measurement is completed.

4-220. Waveforms shown in Figure 4-31 illustrate the measurement sequence for a single measurement on a sine wave, and the accompanying notations indicate the events occurring during the measurement sequence. In Sample/Hold measurements, the circuits must be in the Track Mode from the completion of one measurement until the receipt of the next Sample/Hold Trigger command. For this reason, the DC Input Amplifier is connected to the input terminals during this entire period, and the normal auto-zero cycle of this amplifier cannot be used. Consequently, there is a slight offset voltage present in its output. This offset is removed from the Sample/Hold measurement voltage as follows:

a. The voltage at point 6 (refer to the diagram and waveforms in Figure 4-31) during the run-up period, V_4 , is the algebraic sum of the voltages at points 4 and 5. The voltage at point 4 is the sum of the input signal

held by the Sample/Hold circuits and the offset of the Input Amplifier. The voltage at point 5 during the same period is the inverse of the offset voltage. Ideally, then, the voltage at point 6 is equal to the input signal held by the Sample/Hold circuits ($V_4 + V_5 = \text{input signal}$).

b. During run-down, when the reference voltage is held by the Sample/Hold circuits, the same condition exists. The voltages at points 4 and 5 add, removing the Input Amplifier's offset from the voltage at point 6.

4-221. Sample/Hold Analog Circuits.

4-222. Circuit A. Figure 4-24 contains a simplified diagram of Sample/Hold Circuit A and a discussion of its operation.

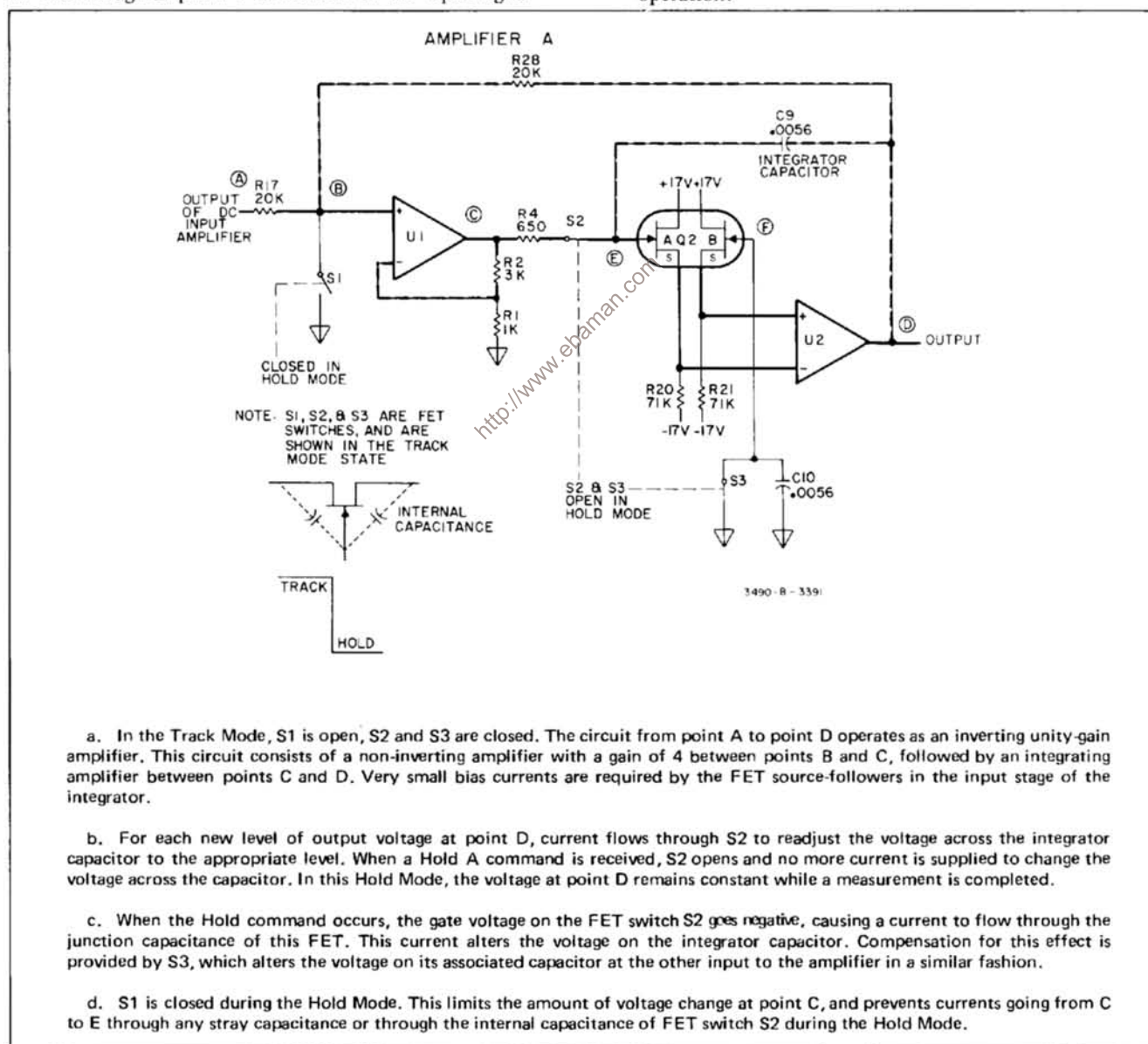

Figure 4-24. Simplified Diagram and Operation of S/H Circuit A.

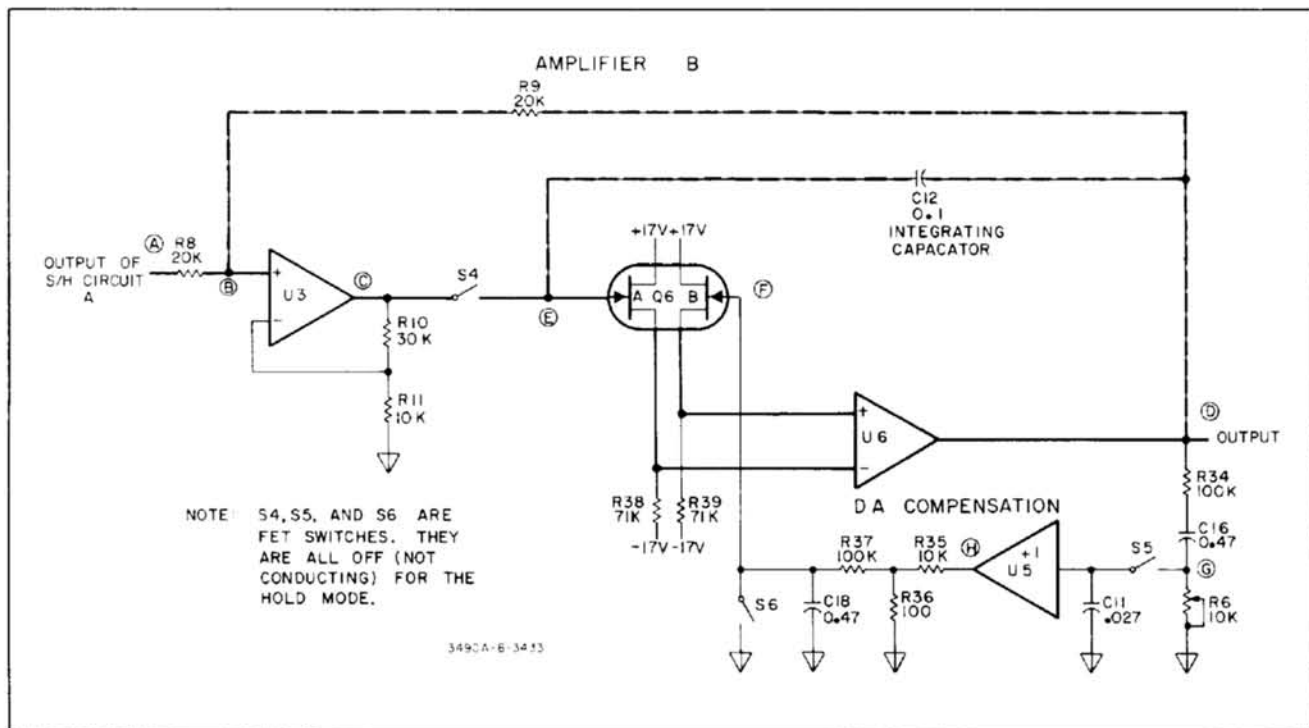

Figure 4-25. Simplified Diagram of S/H Circuit B.

4-223. Circuit B. A simplified diagram of Sample/Hold Circuit B is shown in Figure 4-25. The operation of Sample/Hold Circuit B is similar to the operation of Circuit A. Circuit B responds more slowly than A and is able to hold a constant output level long enough for an accurate measurement to be completed. To allow time for Circuit B to respond to the output of A, the B Hold command occurs about 2 milliseconds after the A Hold command. The purpose of the amplifier circuit shown in Figure 4-25 between points D and F is to compensate for dielectric absorption in the integration capacitor, C12.

4-224. Dielectric Absorption. Dielectric absorption is the memory effect of a dielectric when the voltage across the capacitor is changed suddenly. This may be illustrated by the following example:

1. Charge a capacitor to a given voltage.
2. Quickly discharge the capacitor to zero with a small load resistance.
3. Disconnect the load resistor.
4. The voltage across the capacitor will increase slowly from zero in the direction of the voltage applied in step 1. This voltage will develop quite slowly, but could contribute several counts of error in the Sample/Hold measurement.

This phenomenon becomes significant in the Sample/ Hold integrator circuit when the voltage applied to this

circuit changes from the input signal to the reference voltage, which is opposite in polarity.

4-225. Compensation for Dielectric Absorption. To prevent deterioration of the Sample/Hold output signal due to dielectric absorption, an amplifier circuit is used between the output of Circuit B and the non-inverting input to the integrator portion of this circuit (points D and F in Figure 4-25). The waveforms in Figure 4-26 help to illustrate the action of the Dielectric Absorption (DA) Compensation circuit. During the Track Mode, S5 and S6 (Figure 4-25) are closed. Any change in the output voltage at point D causes current to flow through the rc circuit R34, C16 and R6. This current decreases as C16 assumes the new voltage. The resulting voltage across R6 is applied to C11 and the DA Compensation amplifier input. When a Hold B command occurs, S5 opens and the voltage across C11 remains at the level present at that moment. S6 also opens at this time, allowing C18 to begin charging slowly toward a voltage proportional to the charge on C11. The compensating voltage at point F is the voltage developed across C18. As the time increases between a voltage change at the integrating capacitor and the Hold B command, the need for compensation decreases, and the compensation provided also decreases.

4-226. Offset Amplifier. During Sample/Hold operation, the Auto Zero circuit for the DC Input Amplifier is disabled; consequently, some offset voltage may be present in the amplifier output. This offset will be included in the voltage held by Sample/Hold Amplifiers A and B. During both the run-up and run-down portions of the measurement period, the input to the DC Input

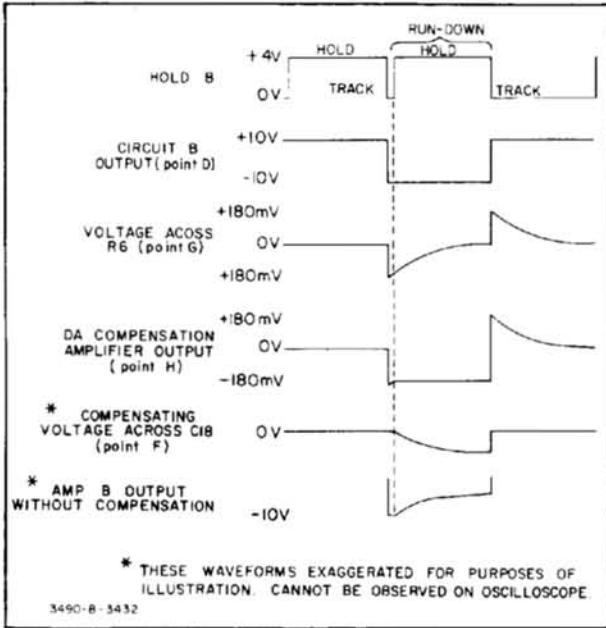

Figure 4-26. Dielectric Absorption Compensation.

Amplifier is shorted, and its output is only the offset present. This offset voltage is inverted by the Offset Amplifier and subtracted from the Sample/Hold signal voltage at the input to the S/H Output Amplifier. The purpose and action of the Offset Amplifier are also mentioned in Paragraph 4-220.

4-227. Output Amplifier. This unity-gain inverting amplifier inverts the output from Circuit B (less the

Offset Amplifier output) and applies this voltage to the Integrator (A - to - D Conversion) circuit through K1, as shown in Figure 4-31. If Sample/Hold operation is not selected, the DC Input Amplifier output signal by-passes the Sample/Hold circuits through K2.

4-228. Sample/Hold Logic Circuits.

4-229. Figure 4-27 is a block diagram of the Sample/Hold logic circuits. The function of each block is discussed in the following paragraphs. The sequence of the main timing signals must be modified for Sample/Hold measurements to allow the Sample/Hold circuits to track the input and reference signals at the proper times. The modified timing also grounds the input to the DC Input Amplifier during the run-up and run-down periods. The Sample/Hold logic circuits also determine the proper delay for Acquire/Hold measurements in accordance with the range selected. The logic circuits are controlled by an Algorithmic State Machine (ASM). A brief explanation of an ASM will be found in Paragraph 4-90.

4-230. Timing and Trigger Circuits. The block diagram in Figure 4-28 details the circuits and signals used in the timing and trigger circuits.

4-231. Sample/Hold State Clock. The input to the Sample/Hold State Clock comes from the 3490A crystal-controlled Clock Oscillator, A1U3. This signal is divided by 16, so that the Sample/Hold State Clock signal has a frequency of 250 kHz in instruments designed for 60 Hz line operation, and 208.3 kHz in

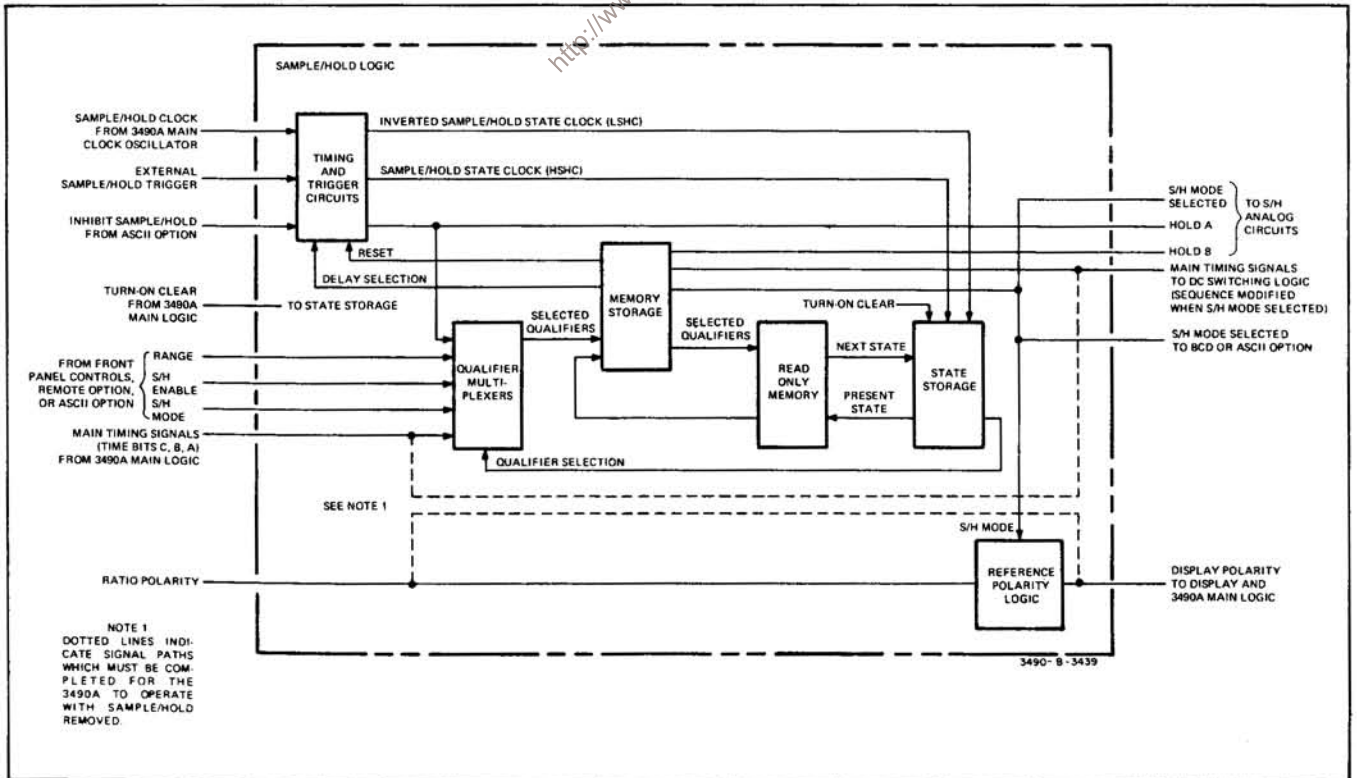

Figure 4-27. Sample/Hold Logic Block Diagram.

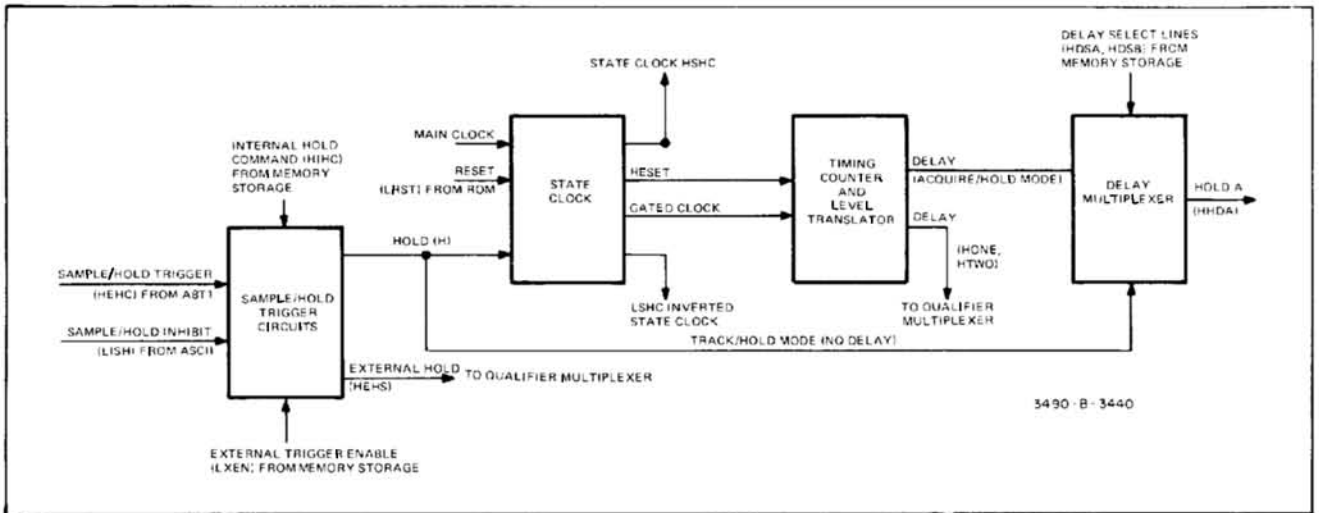

Figure 4-28. Block Diagram of S/H Timing and Trigger Circuits.

50 Hz instruments. Two Sample/Hold State Clock signals which are opposite in phase, HSHC and LSHC, are used to clock the State Storage and Memory Storage flip-flops. All six "next-state" signals are clocked into storage at the same time. One-half clock cycle later, the Memory Storage flip-flops are clocked simultaneously. The clock signal to the Timing Counter is gated by the Hold signal from the Sample/Hold Trigger circuit.

4-232. Timing Counter and Level Translator. The Timing Counter is a 14-stage binary counter/divider. Four outputs from this counter are applied to the Level Translator, which converts the counter output logic levels to the 0 V to +5 V levels used by subsequent circuits. Three outputs from the Level Translator are applied to the Delay Multiplexer and used in selecting the Acquire/Hold delay. The other two Level Translator outputs go to the Qualifier Multiplexer.

4-233. Delay Multiplexer. Two Delay Select lines from Memory Storage select the Delay Multiplexer output from its four input lines. If Track/Hold (no delay) operation is selected, the multiplexer selects the Sample/Hold Trigger Circuit output and issues a Hold A command immediately. When operating in the Acquire/Hold mode, the multiplexer output (Hold A) determines the length of delay between the receipt of a Hold command and the actual beginning of a Hold condition. The delay required is determined by the range selected, and is related to the DC Amplifier gain, as shown in Table 4-5.

4-234. Sample/Hold Trigger Circuits. Figure 4-29 shows the Sample/Hold Trigger timing sequence. An external Sample/Hold Trigger pulse is applied to a pulse-stretching one-shot circuit whose output is a positive pulse approximately 40 microseconds in width, called External Hold H. This output may be inhibited by a LOW true inhibit signal, LISH, from the ASCII option. Also, the External Hold H output must be enabled by a LOW External Trigger Enable signal from the Memory Storage.

Table 4-5. Gain Delay Relationship.

Range	DC Amp. Gain	Delay Select		Nominal Delay (μ s)	
		HDSB	HDSA	Option 060	Option 050
.1 V*	x100	L	L	2048.8	2458.5
1 V	x10	H	L	512.6	615.0
10 V	x1	L	H	128.4	154.0
100 V	x10	H	L	512.6	615.0
1000 V	x1	L	H	128.4	154.0

* Measurement accuracy is not specified for the .1 V range. Operation on this range is not recommended due to the amount of Gaussian (thermal) noise present.

age. If these conditions are correct, this begins a Sample/Hold measurement. The External Hold H pulse also enables the Clock Gate, allowing the Clock signal to start the Timing Counter. After the measurement sequence is begun, the Read Only Memory issues an Internal Hold Command (through Memory Storage) which continues to enable the Clock Gate for the remainder of the measurement. At the same time, a signal from the Memory Storage sets the External

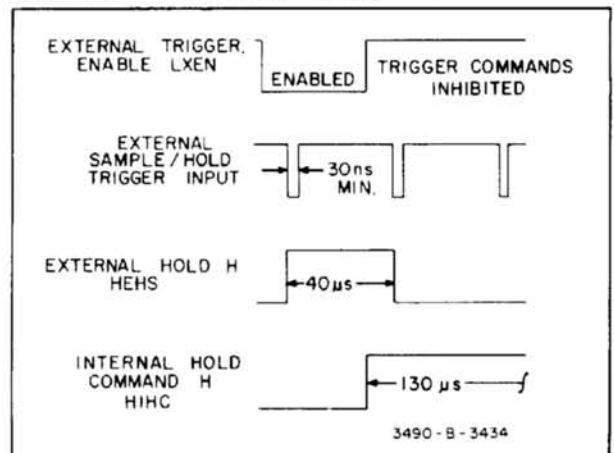

Figure 4-29. Sample/Hold Trigger Timing.

Trigger Enable signal HIGH, inhibiting any further Sample/Hold Trigger pulses for the duration of the measurement sequence. A measurement may also be initiated internally by the Internal Hold Command signal if the 3490A is operating in the automatic sampling mode, or if triggered by the front panel pushbutton.

4-235. Read Only Memory. A microcircuit Read Only Memory (ROM) is the central component of the Sample/Hold Logic control circuits. Six memory inputs in the "present" state, along with two "qualifier" inputs, determine the next state of the ROM. In each state, the ROM provides the proper outputs to determine the next step to be taken in the Sample/Hold measurement sequence.

4-236. State and Memory Storage. The State Storage circuits are cleared when the 3490A is first turned on, so that all six of the State Storage outputs are LOW. Two of the next state outputs are stored in D Flip-Flops which are clocked by the positive-going edge of the clock signal, HSHC. The other four next state outputs are stored in a selectable input storage unit, which is clocked by the negative-going edge of the inverted clock signal, LSHC. Consequently, all six ROM next state outputs are clocked into storage at the same time, because HSHC and LSHC are opposite in phase. The two qualifier inputs, as well as the control signal outputs from the ROM, are clocked into memory storage by the negative-going edge of the clock signal, HSHC. By this method, all state storage circuits are clocked at one time, and all memory storage circuits are clocked at another time.

4-237. Qualifier Multiplexers. The two qualifier inputs to the ROM, along with the six present-state inputs, determine the next-state outputs from the ROM. These qualifier inputs are selected by two 8-line to 1-line multiplexers. Selection is determined by three of the

present-state outputs from State Storage IIPA, IIPB and HPC.

4-238. Sample/Hold Measurement Sequence. The timing sequence for a Sample/Hold measurement is shown in Figure 4-30. The states of Main Time Bits C, B and A must be modified for Sample/Hold measurements in order for the circuits to track the input voltage between measurements. The states of these signals for the various portions of the measurement cycle are shown in the upper part of Figure 4-30. The states shown for a normal measurement (not Sample/Hold) are the states of these signals as received by the Sample/Hold logic circuits. The state sequence for a Sample/Hold measurement is then modified as shown. During a normal measurement (with Sample/Hold in the 3490A), the timing bit sequence is not modified; however, there is a delay in the Storage circuit equal to the duration of one cycle of the Sample/Hold State Clock.

4-239. Reference Polarity Logic. In Sample/Hold measurements, the 3490A input signal is inverted in the Sample/Hold amplifiers. Consequently, the polarity information derived from the Integrator is incorrect. The logic level of the polarity signal must be inverted to supply the correct display polarity and to select the proper reference voltage for run-down. This is accomplished by an Exclusive OR gate and an inverter. The gate output is HIGH if one and only one of its inputs is HIGH. If both inputs are either HIGH or LOW, the output is LOW. In Sample/Hold measurements, one input to the gate is always LOW, so its output follows the polarity signal at the other input. The gate output is then inverted and becomes the Display Polarity signal. When Sample/Hold operation is not selected, one input to the Exclusive OR gate is not always HIGH. The polarity signal at the other input is then inverted by both the gate and the inverter; consequently, the logic level of the Display Polarity signal is the same as the Ratio Polarity signal at the gate input.

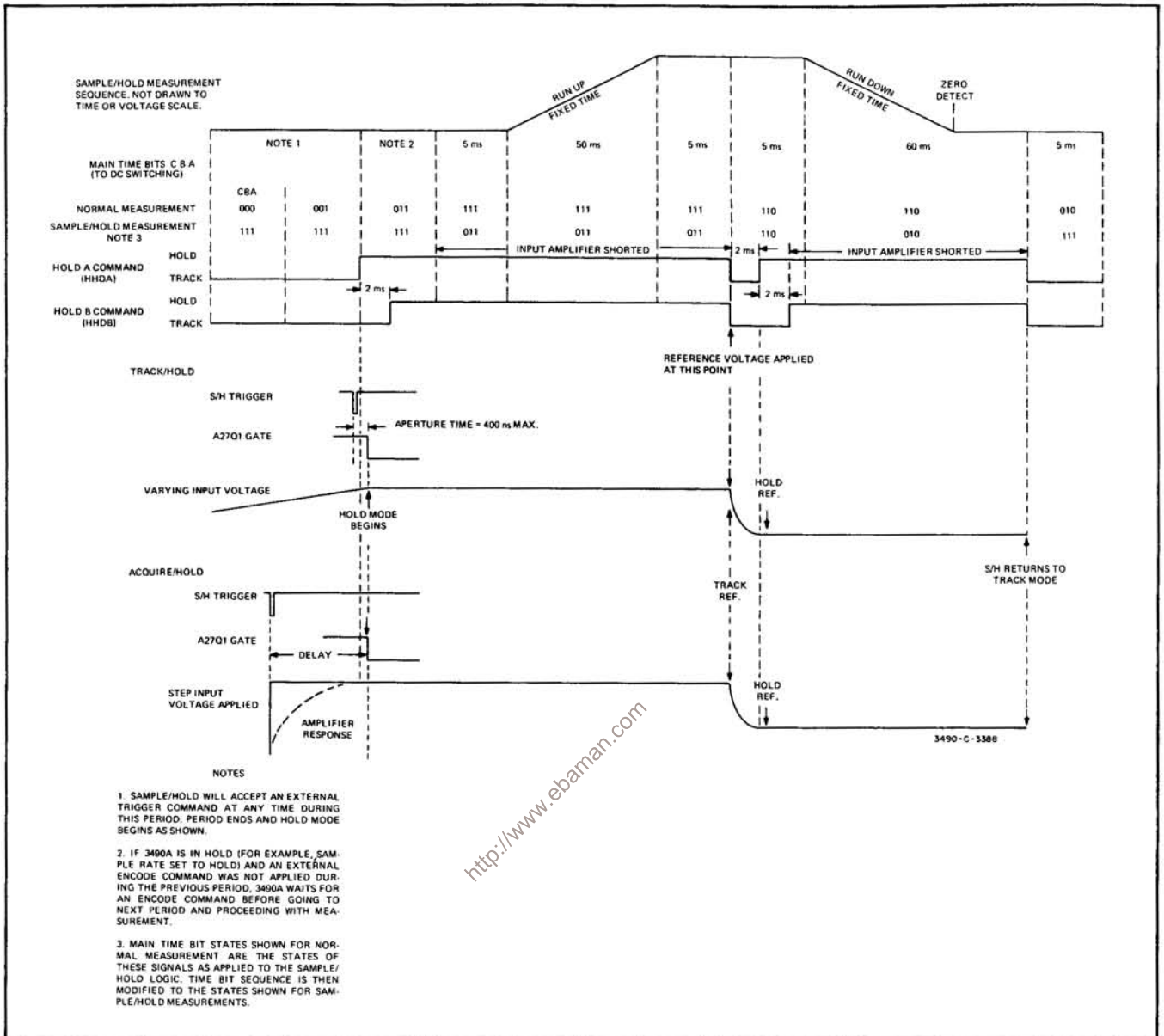
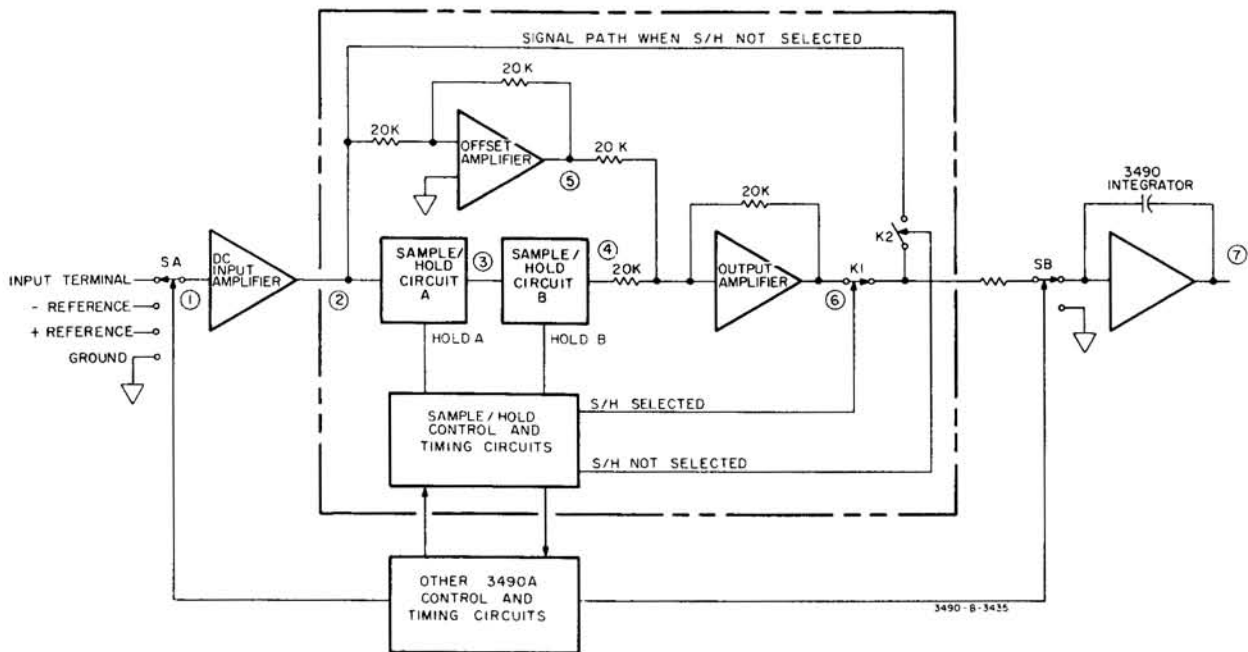

Figure 4-30. Sample/Hold Measurement Sequence.



EXAMPLE OF TRACK/HOLD MEASUREMENT SEQUENCE

- a. During the period $0T_1$, circuits are in the Track Mode and input switch S_A is connected to the Input terminal.
- b. At t_1 a S/H Trigger command is received. Circuit A holds within 400 nanoseconds, and Circuit B holds about 2 milliseconds later.
- c. At t_2 , S_A is switched to ground. $2T_3$ is settling time for the amplifiers.
- d. $3T_4$ is the run-up time for the integrator. S_B is connected to the Integrator input.
- e. From t_4 to t_7 , S_B is closed to ground and no current is supplied to the Integrator.
- f. At t_5 , S_A is switched to the - Reference. $5T_6$ is about 4 ms long. Hold A occurs 2 ms after t_5 and Hold B occurs at t_6 .
- g. S_A is switched to ground at t_6 , and $6T_7$ is used for amplifier settling time.
- h. S_B is switched to the Integrator input during $7T_8$. t_8 is the zero detect point.
- i. At t_0 , all circuits are returned to the Track Mode and S_A is again connected to the Input terminal.

NOTES

1. Waveforms are not drawn to time or voltage scale.
2. Decay of Circuit A output signal, V3, is exaggerated for the purpose of this illustration.

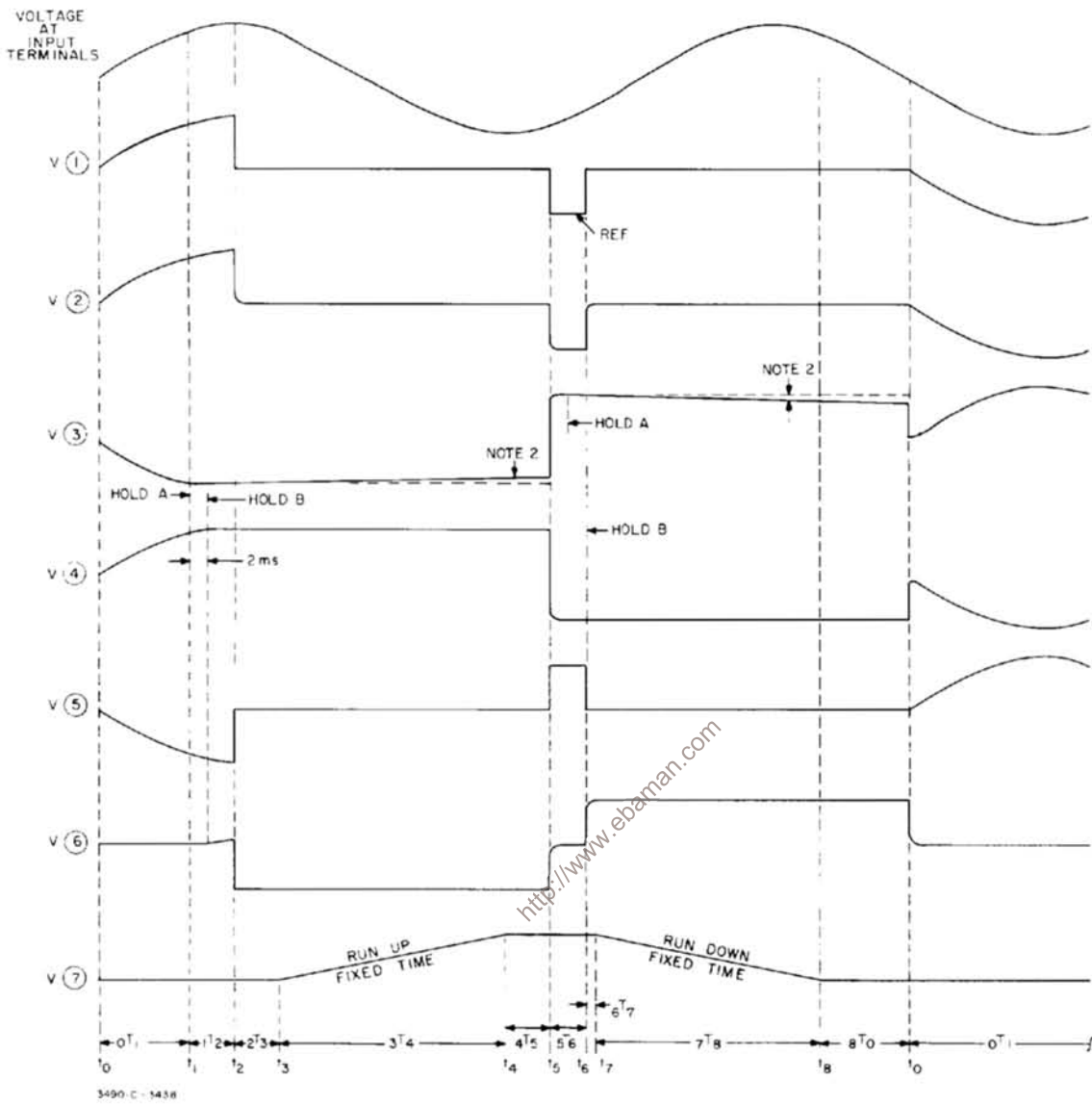

Figure 4-31. Sample/hold Simplified Diagram And Measurement Sequence.

Table 5-1. Recommended Test Equipment.

Instrument Type	Required Characteristics	Use	Recommended Model
DC Voltage Standard	Voltage: 1 mV to 1000 V Accuracy: $\pm 0.005\%$	Performance Checks Adjustments Troubleshooting	-hp- Model 740B DC Standard/ Differential Voltmeter
AC Calibrator	Frequency: 20 Hz to 100 kHz Output Level: 1 mV to 1000 V Accuracy (mid-band): $\pm 0.1\%$ Voltage Stability: $\pm 0.02\%$ for six months	Performance Checks Adjustments Troubleshooting	-hp- Model 745A AC Calibrator -hp- Model 746A High Voltage Amplifier
Resistance Decade	Resistance: 100 Ω to 10 M Ω Accuracy: $\pm 0.004\%$	Performance Checks Adjustments Troubleshooting	General Radio Model GR 1433-Z Decade Resistor
Electronic Counter	Frequency: 50 Hz to 60 Hz	Performance Checks	-hp- Model 5300A/5302A Measuring System
Test Oscillator	Frequency: to 250 kHz Output: 3 Vrms into 50 Ω	Performance Checks	-hp- Model 652A Test Oscillator
DC Differential Voltmeter	Voltage Range: 1 V Resolution: 1 μ V	Performance Checks	-hp- Model 3420B DC Differential Voltmeter
DC Digital Voltmeter	Voltage Range: 10 mV to 1000 V Resolution: 10 μ V	Adjustments Troubleshooting	-hp- Model 3480B/3484A Digital Voltmeter
Oscilloscope	Bandwidth: DC to 10 MHz Sweep: 0.1 μ s to 1 sec/div Sensitivity: 1 V/div Delayed Sweep Delayed Gate Output: negative-going pulse ≥ 2 V amplitude and ≥ 30 ns wide	Performance Checks Adjustments Troubleshooting	-hp- Model 180C/D Oscilloscope with 1801A and 1821A plug-in units
DC Null Voltmeter	Voltage Range: 100 mV to 100 V	Adjustments Troubleshooting	-hp- Model 419A DC Null Voltmeter
Capacitor	Capacitance: 1.0 μ F Voltage: 20 vdcw	Performance Checks	-hp- Part No. 0160-2611
Resistors	Resistances: 1 k Ω $\pm 10\%$ 10 k Ω $\pm 0.1\%$ 1 M Ω $\pm 0.1\%$	Performance Checks	-hp- Part No: 0684-1021 0698-4157 0698-6369
Thermal Converters	Voltages: 1 V 3 V	Performance Checks	-hp- Model 11051A -hp- Model 11050A
Square Wave Generator	Frequency: 100 Hz to 1 kHz Output Level: 20 V p-p Rise Time: ≤ 50	Performance Checks Adjustments Troubleshooting	-hp- Model 3310A Function Generator
Silicon Diode	≤ 20 V piv	Performance Checks Adjustments	-hp- Part No. 1901-0040
Resistor	10 k Ω	Performance Checks Adjustments	-hp- Part No. 0684-1031
Calculator	HP-IB Control Capability Must serve as printer for 3490A output data	HP-IB Operational Check HP-IB Troubleshooting	-hp- 9820A Calc. with 11144A or 59405A HP-IB Calc. Inter- face and Peripheral Control II ROM Block
Logic Comparator	Capable of in-circuit check of dual in line TTL IC packages	Troubleshooting	-hp- 10529T Logic Probe

SECTION V MAINTENANCE

5-1. INTRODUCTION.

5-2. This section contains performance tests and adjustment procedures for the Model 3490A Multimeter. The performance tests determine whether your instrument is operating within its published specifications. The adjustment procedures are provided to help you maintain your instrument within specification limits.

5-3. RECOMMENDED TEST EQUIPMENT.

5-4. Test equipment required for the performance tests and adjustment procedures is listed in Table 5-1. Any equipment that satisfies the critical specifications given

in the table may be substituted for the recommended model.

5-5. TEST RECORD.

5-6. A Performance Test Record is provided at the end of this section for the purpose of recording the results of the Performance Tests. This record lists all of the tested specifications and their acceptable limits. This record can be removed from the manual and retained as a permanent record of the incoming inspection or routine maintenance performed on the instrument. This record may be reproduced for your use without special permission.

PERFORMANCE CHECKS

5-7. PERFORMANCE TESTS.

5-8. Use the following test procedures to determine whether your instrument is operating within its published specifications. The test limits given in the accuracy tests and on the performance test record compare the instrument to the 90-day specifications given in Table 1-1. However, if your accuracy requirements are met by other specifications, such as the 30-day or 6-month specifications, the test limits should be adjusted accordingly. The performance of the instrument should be tested upon receipt and at regular intervals determined by your accuracy requirements. Refer also to Mil. Spec. MIL-C-45662A. If the 3490A fails to meet one or more of its specifications, refer to the Adjustment Procedures, Paragraph 5-51. The 3490A and test equipment should be operated at normal line voltage with the 3490A rear panel line selector switches set as instructed in Figure 2-1. Allow at least one hour warm-up time for the 3490A before beginning the following tests.

5-9. DC VOLTMETER ACCURACY TEST.

5-10. A dc voltage standard (-hp- 740B) is required for this test.



Connect Guard to Input Low or damage to the instrument may result.

- a. Set 3490A FUNCTION to DC, RANGE to .1 V.
- b. Connect dc standard between INPUT HIGH and LOW terminals.

- c. Select 3490A ranges and dc standard positive and negative outputs listed in Table 5-2. Display should be within limits shown in each case.

5-11. AC VOLTMETER ACCURACY TESTS.

5-12. Because of the voltage range and bandwidth of the 3490A ac voltmeter circuits, more than one test setup is required to verify the accuracy specifications. The -hp- Model 745A/746A AC Calibrator may be used to check the accuracy of all ranges at frequencies up to 110 kHz; however, the accuracy of this signal source alone in some cases may not be great enough to ensure a valid test of

Table 5-2. DC Voltmeter Accuracy.

3490A Range	DC Standard Output	Display Limits
.1 V	± 0.01000 V	± .009994 to .010006 V
	± 0.05000 V	± .049990 to .050010 V
	± 0.10000 V	± .099985 to .100015 V
1 V	± 0.10000 V	± 0.09997 to 0.10003 V
	± 0.50000 V	± 0.49993 to 0.50007 V
	± 1.00000 V	± 0.99988 to 1.00012 V
10 V	± 1.00000 V	± 00.9997 to 01.0003 V
	± 10.0000 V	± 09.9988 to 10.0012 V
100 V	± 10.0000 V	± 009.997 to 010.003 V
	± 100.000 V	± 099.988 to 100.012 V
1000 V	± 100.000 V	± 0099.97 to 0100.03 V
	± 500.000 V	± 0499.93 to 0500.07 V
	* ± 1000.00 V	± 0999.88 to 1000.12 V

*If -hp- 740B DC Standard is used, do not apply negative voltage greater than - 500 V.

the 3490A accuracy. In this case, a correction factor chart should be used to adjust the calibrator output. Such a chart for the -hp- 745A/746A may be derived during routine periodic calibration of the instrument, and can be used to set the 745A controls for a precise output. For example, if the 745A output is known to be 0.04 % high at 1 V, 20 Hz, the 745A can be set for a precise 1 V output by setting the 745A voltage set controls to 1.000000 V and adjusting the error measurement control to +0.04 %. The corrected voltage will then be sufficiently accurate to test the 3490A at 1 V, 20 Hz. To determine the length of time that the correction factor chart will be valid, refer to the latest 745A/746A Operating and Service Manuals.

5-13. To verify the ac voltage accuracy of the 3490A at frequencies above 110 kHz, the ac to dc transfer measurement technique may be employed. Using the test setup shown in Figure 5-1, apply an accurate dc voltage to the thermal converter and adjust the dc differential voltmeter for a null indication. Remove the dc input from the thermal converter and apply the ac signal to both the thermal converter and the 3490A input simultaneously. Adjust the test oscillator output level to return the differential voltmeter to a null indication. This results in an rms value of the ac signal equal to the rms value of the dc standard output.

5-14. Table 5-3 lists the voltage and frequency points which should be checked to verify the ac voltage accuracy of the 3490A, together with the test equipment needed for each check. If the equipment required for some checks is not available, a good indication of performance can still be obtained by checking the points for which suitable equipment is available.



Connect Guard to Input Low or damage to the instrument may result.

5-15. OHMMETER ACCURACY TESTS.

5-16. Preferred Method.

5-17. A resistance decade with settings from 100 Ω to 10 M Ω is required for this test. A correction factor chart for the decade is necessary to achieve the accuracy required to check the performance of the 3490A Ohmmeter function. Select the 3490A ranges and resistance decade settings shown in Table 5-4. The algebraic sum of the 3490A reading and the resistance decade error indicated by the correction factor chart should be within the limits given for each setting listed.

5-18. Alternate Method.

5-19. If a suitable resistance decade with an appropriate correction factor chart is not available, resistors within the values shown in Table 5-5, whose value is known to within the tolerances given, may be used to check performance of the 3490A ohmmeter function. The 3490A display should be within the number of counts shown from the value of the resistor used.

5-20. DC COMMON-MODE REJECTION TEST.

5-21. Effective common-mode rejection is the ratio of the peak common-mode voltage to the resultant error in reading, with a 1 k Ω imbalance between High and Low

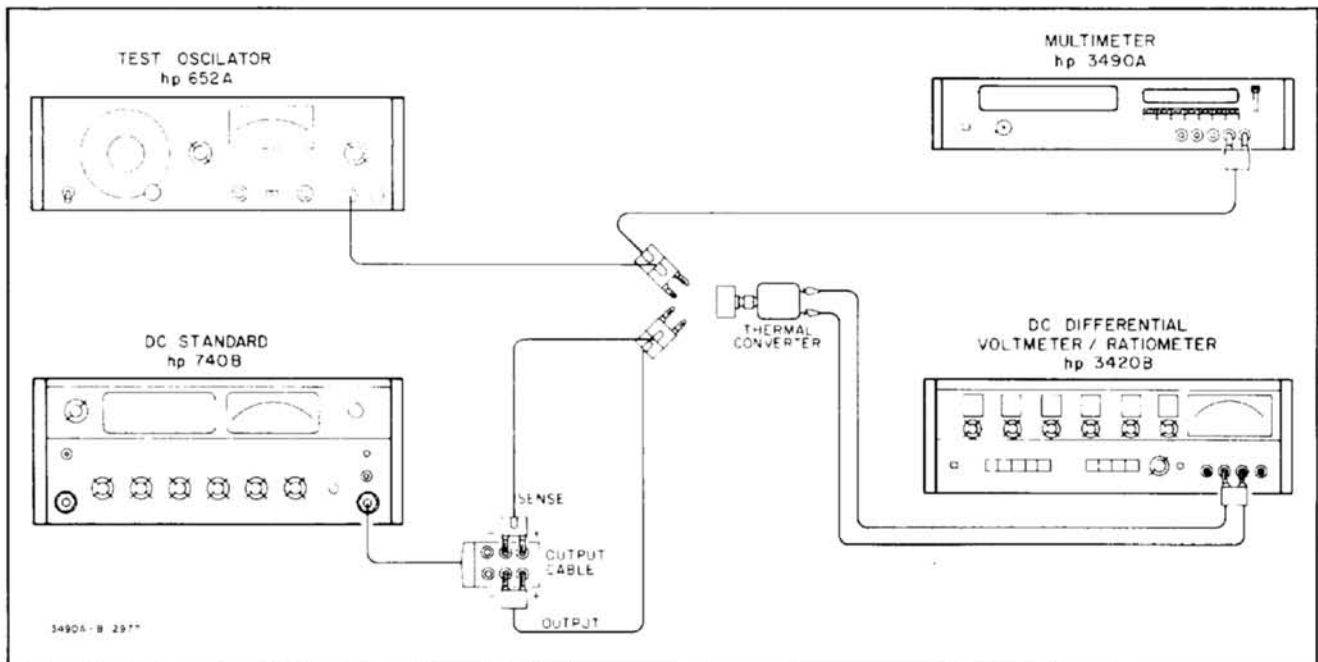

Figure 5-1. AC Voltmeter High Frequency Accuracy Test.

Table 5-3. AC Voltmeter Accuracy.

3490A Range	Test Signal		3490A Max Display Error	Test Signal Source	Other Equipment Required
	Voltage	Frequency			
1 V	1 V	20 Hz	± 400 counts	AC Calibrator	
1 V	1 V	10 kHz	± 125 counts		
1 V	1 V	100 kHz	± 125 counts		
10 V	1 V	100 kHz	± 35 counts		
10 V	5 V	20 kHz	± 75 counts		
10 V	10 V	20 Hz	± 400 counts		
100 V	10 V	100 Hz	± 35 counts		
100 V	100 V	50 kHz	± 125 counts		
1000 V	1000 V	10 kHz	± 135 counts		
1000 V	1000 V	100 Hz	± 125 counts		
1 V	1 V	250 kHz	± 810 counts	Test Oscillator	1 V Thermal Converter DC Differential Voltmeter
10 V	3 V	250 kHz	± 285 counts	Test Oscillator	3 V Thermal Converter DC Differential Voltmeter

Table 5-4. Ohmmeter Accuracy.

3490A Range	Decade Setting	Display Limits
.1 kΩ	100 Ω	.099983 to .100017
1 kΩ	1 kΩ	0.99988 to 1.00012
10 kΩ	10 kΩ	9.9988 to 10.0012
100 kΩ	100 kΩ	99.988 to 100.012
1,000 kΩ	1 MΩ	999.86 to 1000.14
10,000 kΩ	10 MΩ	9996.3 to 10003.7

with Guard connected to High. A dc standard (hp 740B) is required for this test.

a. Connect a 1 kΩ resistor between input High and Low terminals, and connect High to Guard as shown in Figure 5-2.

b. Set 3490A FUNCTION to DC, RANGE to 1 V. Note 3490A display.

c. Connect dc standard between High terminal and the 3490A chassis.

d. Set dc standard output to + 500.00 V. 3490A reading should not change more than 0.00005 V, verifying dc common-mode rejection > 140 dB, where:

$$ECMR = 20 \log \frac{\text{Peak common-mode voltage}}{\text{Effect on reading (volts)}}$$

Table 5-5. Alternate Ohmmeter Accuracy Test.

3490A Range	Resistor		Display Tolerance
	Value	Tolerance	
.1 kΩ	90 to 110 Ω	± 0.0025%	± 17 counts
1 kΩ	900 to 1.1 kΩ	± 0.0025%	± 12 counts
10 kΩ	9 kΩ to 11 kΩ	± 0.0025%	± 12 counts
100 kΩ	90 kΩ to 110 kΩ	± 0.0025%	± 12 counts
1,000 kΩ	900 kΩ to 1.1 MΩ	± 0.005%	± 14 counts
10,000 kΩ	9MΩ to 11 MΩ	± 0.01%	± 37 counts

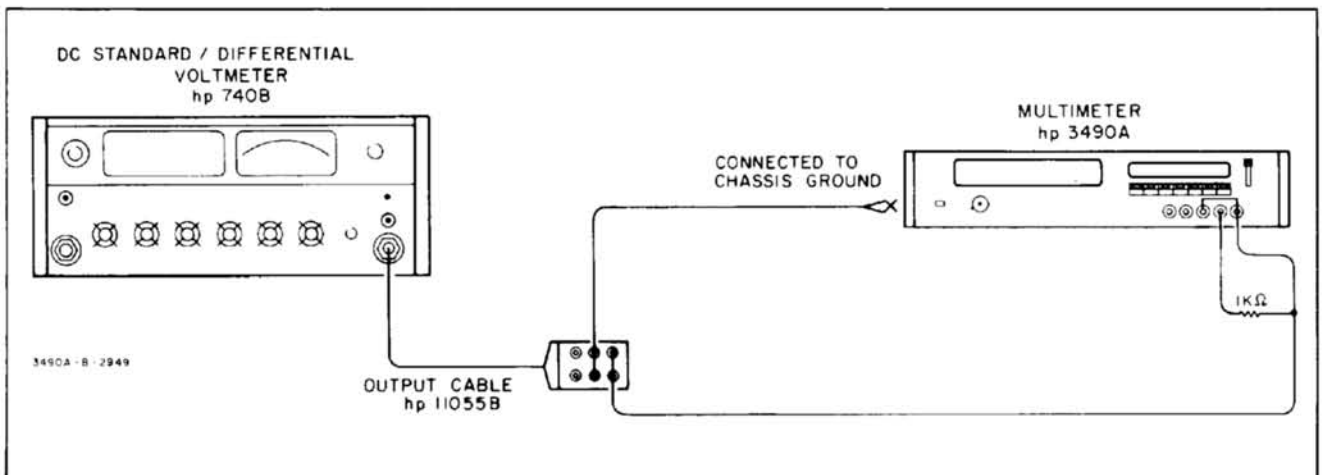

Figure 5-2. DC Common-Mode Rejection Test.

5-22. AC COMMON-MODE REJECTION TEST.

5-23. An ac calibrator (-hp- 745A) and an electronic counter (-hp- 5300A) are required for this test.

a. Connect a 1 k Ω resistor between input High and Low terminals, and connect High to Guard as shown in Figure 5-3.

b. Connect electronic counter to ac calibrator output and adjust calibrator frequency to 60 Hz \pm 0.1 % if the 3490A is designed for 60 Hz line operation, 50 Hz \pm 0.1 % if it is a 50 Hz model.

c. Before connecting ac calibrator output to 3490A, set 3490A FUNCTION to DC, RANGE to 1 V. Note 3490A reading.

d. Connect ac calibrator to 3490A as indicated in Figure 5-3 and set output voltage to 70.7 Vrms (100 V peak).

e. 3490A reading should not change more than 0.00001 V from the reading noted in step c, verifying ac common-mode rejection of \geq 140 dB at the frequency specified (50 Hz or 60 Hz), using the formula given in Paragraph 5-21.

5-24. AC NORMAL-MODE REJECTION TEST.

5-25. AC normal-mode rejection is the ratio of the peak normal-mode voltage to the resultant error in reading. An ac calibrator (-hp- 745A) and an electronic Counter (-hp- 5300A) are required for this test.

a. Connect test equipment as shown in Figure 5-4. Do not connect to 3490A input.

b. Using an electronic counter as a monitor, adjust ac calibrator frequency for 60 Hz \pm 0.1 % if 3490A is designed for 60 Hz line operation, or 50 Hz \pm 0.1 % if it is a 50 Hz model.

c. Set 3490A FUNCTION to DC, RANGE to 10 V, short Input. Note 3490A reading.

d. Disconnect input short and connect calibrator to 3490A input. Adjust calibrator amplifier to 7.07 Vrms (10 V peak).

e. 3490A reading should not vary more than \pm 00.0316 V from reading noted in Step c. This verifies normal-mode rejection of \geq 50 dB at 60 Hz (or 50 Hz), where:

$$\text{NMR} = 20 \log \frac{\text{Peak ac superimposed voltage}}{\text{Effect on reading (volts)}}$$

5-26. DC VOLTMETER INPUT RESISTANCE TEST.

5-27. A dc standard (-hp- 740B) and a 1 M Ω \pm 0.1 % resistor (-hp- 0698-6369) are required for this test.



Connect Guard to Input Low or damage to the instrument may result.

a. Connect 3490A, dc standard and resistor as shown in Figure 5-5.

b. Set 3490A FUNCTION to DC, RANGE to 10 V.

c. Connect jumper across 1 M Ω resistor as indicated. Adjust dc standard output to 10.0000 V. Note 3490A reading.

d. Remove jumper from 1 M Ω resistor. 3490A reading should not change more than 00.0010 V, verifying input resistance $>$ 10¹⁰ Ω .

e. Set 3490A RANGE to 100 V. Reduce input to 1.00000 V.

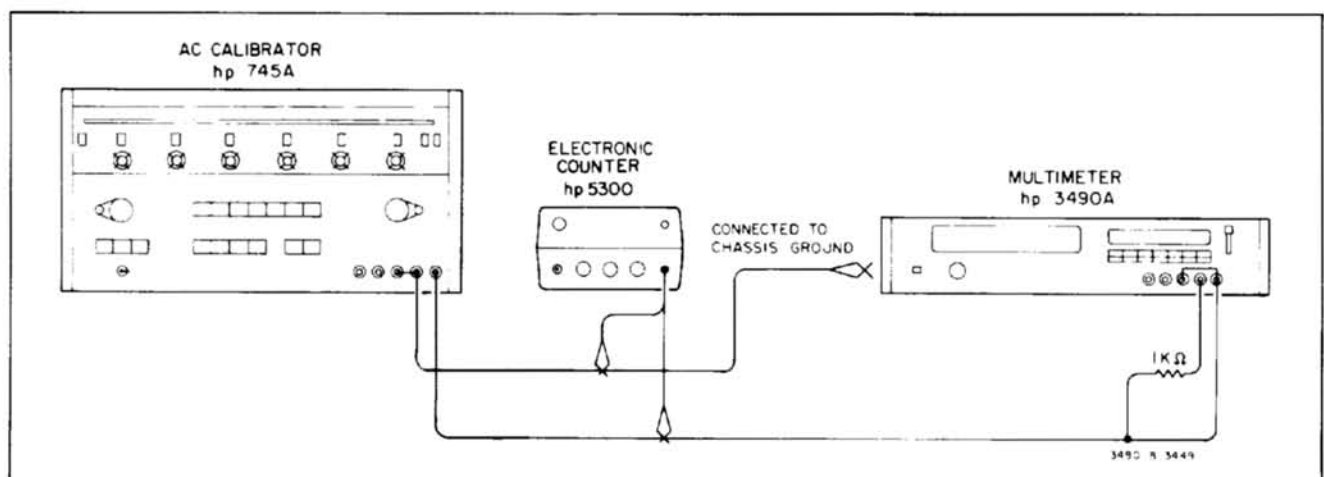

Figure 5-3. AC Common-Mode Rejection Test.

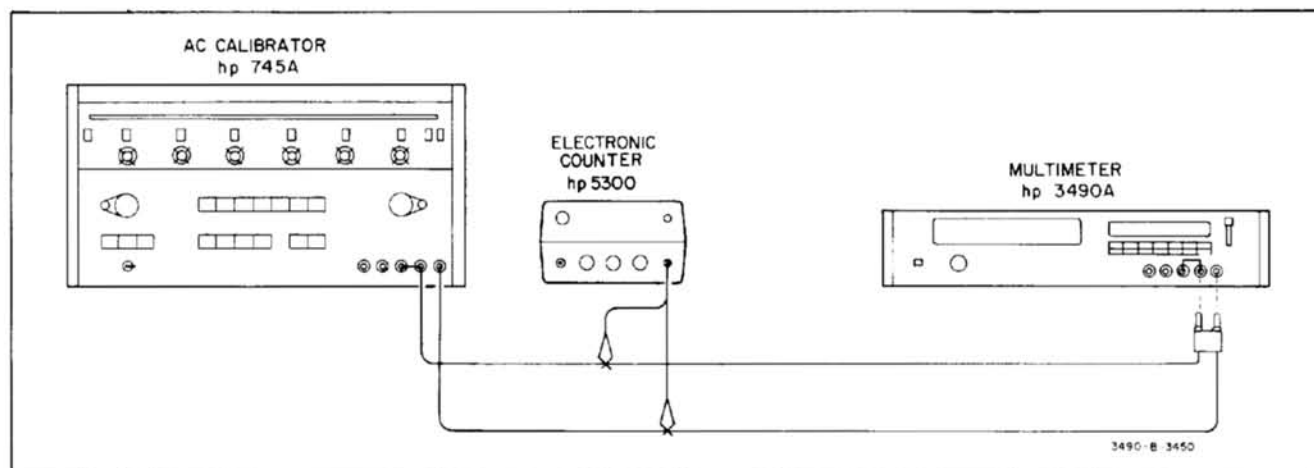

Figure 5-4. AC Normal-Mode Rejection Test.

f. Connect jumper across $1\text{ M}\Omega$ resistor and note 3490A reading.

g. Remove jumper. 3490A reading should change between 000.908 V and 000.910 V . This verifies an input resistance of $10\text{ M}\Omega \pm 0.15\%$.

5-28. AC VOLTMETER INPUT IMPEDANCE TEST.

5-29. A test oscillator (-hp- 652A) and two precision resistors, $1\text{ M}\Omega \pm 0.1\%$ (-hp- 0698-6369) and $10\text{ k}\Omega \pm 0.1\%$ (-hp- 0698-4157), are required for this test.

a. Connect 3490A, test oscillator, and $1\text{ M}\Omega$ resistor (R_S) as shown in Figure 5-6. Connect jumper across resistor as indicated.

b. Set 3490A FUNCTION to AC, RANGE to 1 V .

c. Adjust test oscillator frequency to 25 Hz . Adjust output amplitude to obtain a 3490A reading of 1.00000 V .

d. Remove jumper from resistor R_S . 3490A display should be not less than 0.65975 V if the instrument does not have the rear input connector, or not less than 0.65804 if it does have a rear input connector in parallel with the front input terminals.

e. Replace the $1\text{ M}\Omega$ resistor (R_S) with a $10\text{ k}\Omega$ resistor. Connect jumper across resistor.

f. Adjust test oscillator frequency to 250 kHz . Adjust output amplitude for 3490A reading of 1.00000 V .

g. Remove jumper from $10\text{ k}\Omega$ resistor. 3490A display should be not less than 0.49211 V if the 3490A does not have rear input connector, or not less than 0.41321 V if it does have the rear input.

5-30. SAMPLE/HOLD PERFORMANCE (Option 040/045).

5-31. The dc voltage measurement performance of the 3490A must be within specification before proceeding

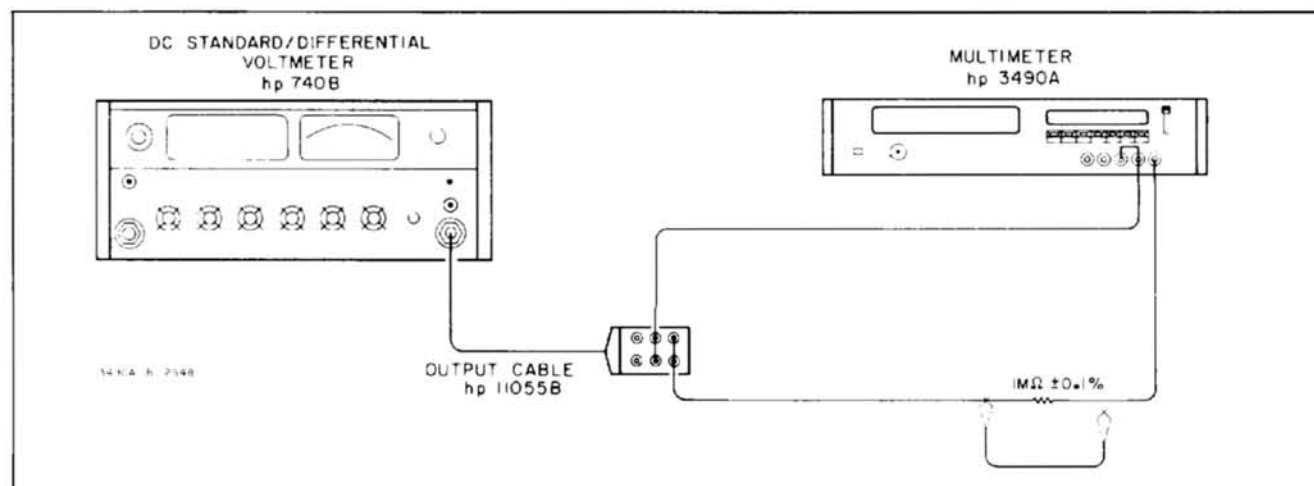

Figure 5-5. DC Voltmeter Input Resistance Test.

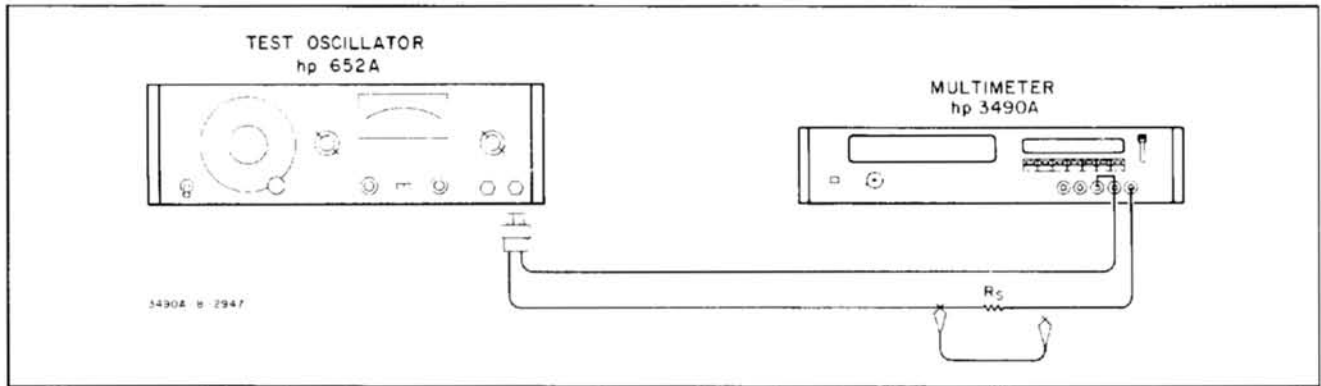

Figure 5-6. AC Voltmeter Input Impedance Test.

with the Sample/Hold performance tests. Refer to Paragraph 5-9.

5-32. Sample/Hold DC Measurement Accuracy Test.

5-33. A dc standard (-hp- 740B) is required for this procedure, which checks the dc voltage accuracy of the Sample/Hold circuits to the 90-day specification in both Track/Hold and Acquire/Hold operation. Accuracy is not specified for the .1 V range.



Connect Guard to Input Low or damage to the instrument may result.

- Set 3490A FUNCTION to DC, RANGE to 1 V, SAMPLE/HOLD to TRACK/HOLD, SAMPLE RATE fully clockwise.
- Connect dc standard between input High and Low terminals.
- Select 3490A ranges and dc standard positive and negative outputs listed in Table 5-6. Display should be within limits shown in each case.
- Set SAMPLE/HOLD to ACQUIRE/HOLD and repeat step c.

5-34. Sample/Hold Response Test.

5-35. A function generator (-hp- 3310A), an oscilloscope with delayed sweep and delayed gate output (-hp- 180C/1801A/1821A), a silicon diode, and a 10 k Ω resistor are required for this test, which verifies that the Sample/Hold circuits will respond to a step input voltage within the stated acquisition time. The Delayed Gate Output from the oscilloscope must be a negative-going pulse at least 30 nanoseconds wide and having an amplitude of 2 to 200 V.

- Connect equipment as shown in Figure 5-7. If the 3490A has BCD/Remote Expand Option 020, also

Table 5-6. Sample/Hold DC Accuracy Check.

3490A Range	DC Standard Output	Display Limits
1 V	± 0.10000 V	± 0.0998 to 0.1002 V
	± 0.50000 V	± 0.4998 to 0.5002 V
	± 1.00000 V	± 0.9997 to 1.0003 V
10 V	± 1.00000 V	± 00.998 to 01.002 V
	± 5.00000 V	± 04.998 to 05.002 V
	± 10.0000 V	± 09.997 to 10.003 V
100 V	± 10.0000 V	± 009.98 to 010.02 V
	± 50.0000 V	± 049.98 to 050.02 V
	± 100.000 V	± 099.97 to 100.03 V
1000 V	± 100.000 V	± 0099.8 to 0100.2 V
	± 500.000 V	± 0499.8 to 0500.2 V
	* ± 1000.00 V	± 0999.7 to 1000.3 V

* If -hp- 740B DC Standard is used, do not apply negative voltage greater than -500 V.

connect Stretched Pulse Output (J7 pin 10) to External Enclave (J7 pin 28).

- Set 3490A FUNCTION to DC, RANGE to 10 V, SAMPLE/HOLD to TRACK/HOLD, SAMPLE RATE to HOLD.
- Set oscilloscope controls for External Trigger, negative slope, and Main sweep. Set Main sweep to .1 ms/div., Delayed sweep to 1 μ s/div.
- Set function generator to square wave, frequency to 1 kHz, and adjust output level for 20 V peak-to-peak signal as displayed on oscilloscope.
- Adjust oscilloscope delay control so that intensified trace begins approximately 450 μ s after negative-going transition of square wave. Note 3490A reading, which should be near zero.
- Adjust delay so that intensified trace begins approximately 125 μ s after negative-going edge of square wave (stated maximum acquisition time for 10 V range is 128 μ s). Reading should be within ± 0.001 V of the reading noted in step e.

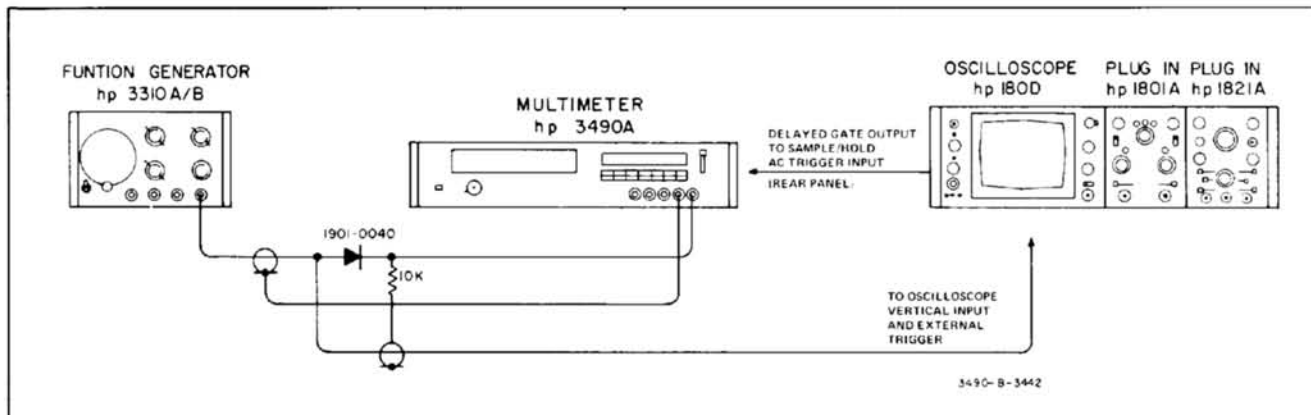

Figure 5-7. Sample/Hold Response Test.

- g. Set oscilloscope main sweep to .5 ms/div.
- h. Adjust function generator frequency to 200 Hz, output level to 2 V peak-to-peak.
- i. Set 3490A RANGE to 1 V.
- j. Adjust intensified trace to approximately 1 ms after the negative-going edge of square wave. Note reading, which should be near zero.
- k. Adjust intensified trace to approximately 500 μs after the negative-going edge of square wave. Reading should be within ± 0.001 V of reading noted in step j.

5-36. RATIO PERFORMANCE (Option 080).

5-37. The dc and ac voltage measurement performance of the 3490A must be within specifications before proceeding with the ratio performance tests. Refer to Paragraphs 5-9 and 5-11.

5-38. DC/DC Ratio Accuracy Tests.

5-39. Preferred Method. Two dc standards (-hp- 740B) are necessary for this method, making it possible to check performance at various levels of EXT REF voltage and INPUT voltage. Both dc standards must be floating,

since INPUT Low and EXT REF Low terminals are connected internally. If only one dc standard is available, go to Paragraph 5-40.

- a. Set 3490A RATIO switch to EXT REF 1 V. Connect a dc standard to 3490A INPUT terminals and adjust standard output to + 0.10000 V.
- b. Set 3490A FUNCTION to DC, RANGE to 1 V. Connect a second dc standard to 3490A INPUT terminals and adjust standard output to + 0.10000 V. 3490A display should be + 0.99955 to + 1.00045.

c. Select EXT REF and INPUT ranges and voltages listed in Table 5-7. Display should be within limits shown in each case.

5-40. Alternate Method. A dc standard (-hp- 740B) and a second voltage source having an output of 10 V ± 5 %, stable to within 1 mV/hr, are required for this method. Both the dc standard and the second voltage source must be floating. A 9.8 V mercury battery (Mallory TRI77) is a satisfactory source. The following procedure will refer to the second voltage source as the battery.

- a. Set 3490A RATIO switch to INT REF, FUNCTION to DC, RANGE to 10 V.

Table 5-7. DC/DC Ratio Accuracy Test.

Ext Ref Range	Ext Ref Voltage	Input Range	Input Voltage	Display Limits
1 V	+ 0.10000 V	1 V	+ 0.10000 V	+ 0.99955 to + 1.00045
1 V	+ 0.50000 V	1 V	+ 0.50000 V	+ 0.99979 to + 1.00021
1 V	+ 1.00000 V	1 V	+ 1.00000 V	+ 0.99982 to + 1.00018
1 V	+ 1.00000 V	1 V	- 1.00000 V	- 0.99982 to - 1.00018
1 V	- 1.00000 V	1 V	- 1.00000 V	+ 0.99982 to + 1.00018
1 V	- 1.00000 V	1 V	+ 1.00000 V	- 0.99982 to - 1.00018
1 V	+ 1.20000 V	1 V	+ 1.00000 V	+ 0.83316 to + 0.83350
10 V	+ 1.00000 V	10 V	+ 1.00000 V	+ 09.9955 to + 10.0045
10 V	+ 5.00000 V	10 V	+ 5.00000 V	+ 09.9979 to + 10.0021
10 V	+ 10.0000 V	100 V	+ 100.000 V	+ 099.979 to + 100.021
10 V	+ 12.0000 V	100 V	+ 100.000 V	+ 083.313 to + 083.353

b. Connect the battery to INPUT terminals, + to HIGH, - to LOW. Note and record 3490A display.

c. Connect dc standard to EXT REF terminals and set standard output to positive voltage equal to display noted in step b.

d. SET 490A RATIO switch to EXT REF 10 V. Display should be + 09.9982 to + 10.0018.

e. Reverse polarity of dc standard output. Display should be - 09.9982 to - 10.0018.

f. Set RATIO switch to INT REF. Reverse polarity of battery connections. Note and record display.

g. Set RATIO switch to EXT REF 10 V. Adjust dc standard output to negative voltage equal to display noted in step f. Display should now be + 09.9982 to + 10.0018.

h. Reverse polarity of dc standard output. Display should be - 09.9982 to - 10.0018.

i. Reduce dc standard output to 1/10 the output used in step h.

j. Set RATIO switch to EXT REF 1 V. Display should be - 09.9982 to - 10.0018.

5-41. AC/DC Ratio Accuracy Test.

5-42. A dc standard (-hp- 740B) and an ac calibrator (-hp-745A) are required for this test.

a. Set 3490A RATIO switch to EXT REF 1 V. Connect dc standard to EXT REF terminals and adjust standard output to + 0.10000 V.

b. Set 3490A FUNCTION to AC, RANGE to 1 V. Connect ac calibrator to INPUT terminals and adjust calibrator output to 100 mV at 100 Hz. Display should be 0.99865 to 1.00135.

c. Select EXT REF and INPUT ranges and voltages listed in Table 5-8. Display should be as indicated in each case.

5-43. External Reference Input Resistance Test.

5-44. A dc standard (-hp- 740B) and a 10 k Ω \pm 0.1 % resistor (-hp- 0698-4157) are required for this test.

a. Set 3490A RATIO switch to EXT REF 10 V, FUNCTION to DC, RANGE to 10 V.

b. Connect 3490A, dc standard and 10 k Ω resistor as shown in Figure 5-8. Connect jumper across resistor.

c. Adjust dc standard output to + 10.0000 V. Note 3490A display.

d. Remove jumper across resistor. Display should not change more than 100 counts, verifying an EXT REF input resistance of $> 10^7 \Omega$.

5-45. HP-IB OPERATIONAL CHECK (Option 030).

5-46. A Hewlett-Packard Interface Bus system controller and a printer are required to verify the operation of the 3490A Option 030. Two procedures are given. The first, in Paragraph 5-47, is a general procedure to be used with any bus controller. The second, in Paragraph 5-49, is essentially the same procedure written specifically for the 9820A Calculator. If the 3490A I/O circuits fail to operate correctly, refer to the HP-IB troubleshooting information, Paragraph 7-49.

1. Initialize

IFC - Set Interface Clear LOW
IFC - Return Interface Clear HIGH
REN - Set Remote Enable LOW

2. Send addresses (see Paragraph 3-104 for 3490A address codes).

ATN - Set Attention LOW
? (77₈) - Universal unlisten command
6 (66₈) - 3490A listen address (3490A placed in remote mode)
ATN - Set Attention HIGH

3. Send programming instructions

F }
3 } Test No. 1
R }
7 }

Table 5-8. AC/DC Ratio Accuracy Test.

Ext Ref Range	Ext Ref Voltage	Input Range	Input Voltage	Display Limits
1 V	0.50000 V	1 V	0.50000 V	0.99865 to 1.00135
1 V	1.00000 V	1 V	1.00000 V	0.99865 to 1.00135
1 V	1.20000 V	1 V	1.00000 V	0.83218 to 0.83448
10 V	1.00000 V	10 V	1.00000 V	09.9865 to 10.0135
10 V	5.00000 V	10 V	5.00000 V	09.9865 to 10.0135
10 V	10.0000 V	10 V	10.0000 V	09.9865 to 10.0135
10 V	12.0000 V	10 V	10.0000 V	08.3218 to 08.3448

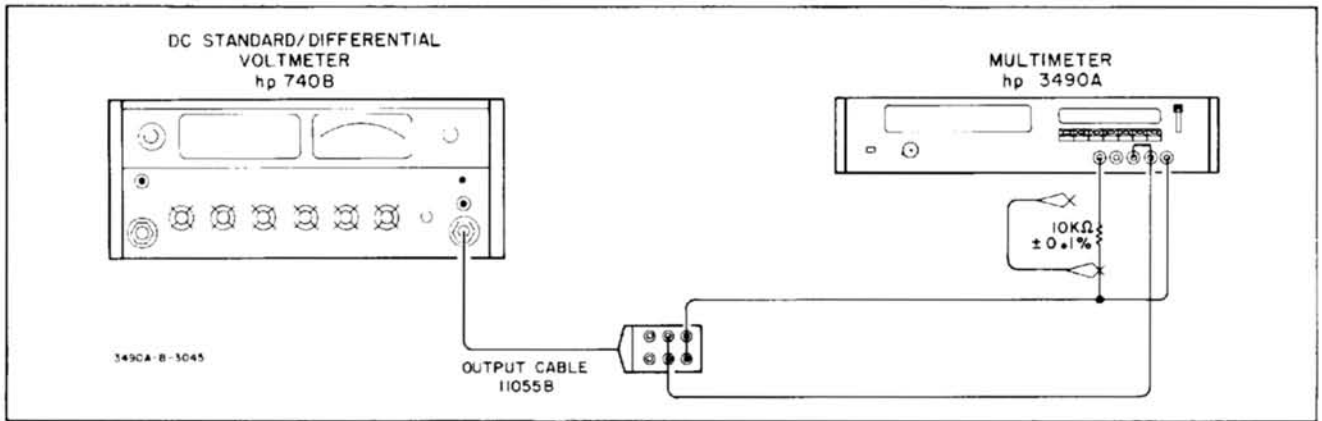

Figure 5-8. External Reference Input Resistance Test.

- M } Single Reading with Output
- 3 }
- T } Immediate Internal Trigger
- 1 }
- E - Execute
- 4. Send addresses
 - ATN - Set Attention LOW
 - ? - Unlisten command
 - V (126g)- 3490A talk address
 - Address of listener
 - ATN - Set Attention HIGH
- 5. Accept 3490A output
 - Check for logic test sequence
- 6. Have 10 readings been made?
 - Yes - Go to 10
 - No - Continue
- 7. Send addresses
 - ATN - Set Attention LOW
 - ? - Unlisten command
 - 6 - 3490A listen address
 - Address of talker
 - ATN - Set Attention HIGH
- 8. Send programming instruction
 - E - Execute
- 9. Go to 4
- 10. Send addresses
 - ATN - Set Attention LOW
 - ? - Unlisten command
 - 6 - 3490A listen address
 - Address of talker
 - ATN - Set Attention HIGH
- 11. Send programming instruction
 - F } DC
 - 0 }

- R } 10 V Range
- 4 }
- E
- 12. Send addresses
 - ATN - Set Attention LOW
 - ? - Unlisten command
 - V - 3490A talk address
 - Address of listener
 - ATN - Set Attention HIGH
- 13. Accept 3490A reading
 - Check for DC
- 14. Send addresses
 - ATN - Set Attention LOW
 - ? - Unlisten command
 - 6 - 3490A listen address
 - Address of talker
 - ATN - Set Attention HIGH
- 15. Send programming instructions
 - F } AC
 - 2 }
 - E
- 16. Send addresses
 - ATN - Set Attention LOW
 - ? - Unlisten command
 - V - 3490A talk address
 - Address of listener
 - ATN - Set Attention HIGH
- 17. Accept 3490A reading
 - Check for AC
- 18. Send addresses
 - ATN - Set Attention LOW
 - ? - Unlisten command
 - 6 - 3490A listen address
 - Address of talker
 - ATN - Set Attention HIGH

19. Send programming instructions
 F } KO
 1 }
 R }
 6 } .1 kΩ Range
 E
20. Send addresses
 ATN - Set Attention LOW
 ? - Unlisten command
 V - 3490A talk address
 - Address of listener
 ATN - Set Attention HIGH
21. Accept 3490A reading
 Check for KO and .1 kΩ range
22. Send addresses
 ATN - Set Attention LOW
 ? - Unlisten command
 6 - 3490A listen address
 - Address of talker
 ATN - Set Attention HIGH
23. Send programming instructions
 R } 1 kΩ Range
 5 }
 E
24. Send addresses
 ATN - Set Attention LOW
 ? - Unlisten command
 V - 3490A talk address
 - Address of listener
 ATN - Set Attention HIGH
25. Accept 3490A reading
 Check for 1 kΩ range
26. Send addresses
 ATN - Set Attention LOW
 ? - Unlisten command
 6 - 3490A listen address
 - Address of talker
 ATN - Set Attention HIGH
27. Send programming instructions
 R } 10 kΩ range
 4 }
 E
28. Send addresses
 ATN - Set Attention LOW
 ? - Unlisten command
 V - 3490A talk address
 - Address of listener
 ATN - Set Attention HIGH
29. Accept 3490A reading
 Check for 10 kΩ range
30. Send addresses
 ATN - Set Attention LOW
 ? - Unlisten command
 6 - 3490A listen address
 - Address of talker
 ATN - Set Attention HIGH
31. Send programming instructions
 R } 100 kΩ Range
 3 }
 E
32. Send addresses
 ATN - Set Attention LOW
 ? - Unlisten command
 V - 3490A talk address
 - Address of listener
 ATN - Set Attention HIGH
33. Accept 3490A reading
 Check for 100 kΩ range
34. Send addresses
 ATN - Set Attention LOW
 ? - Unlisten command
 6 - 3490A listen address
 - Address of talker
 ATN - Set Attention HIGH
35. Send programming instruction
 R } 1000 kΩ range
 2 }
 E
36. Send addresses
 ATN - Set Attention LOW
 ? - Unlisten command
 V - 3490A talk address
 - Address of listener
 ATN - Set Attention HIGH
37. Accept 3490A reading
 Check for 1000 kΩ range
38. Send address
 ATN - Set Attention LOW
 ? - Unlisten command
 6 - 3490A listen address
 - Address of talker
 ATN - Set Attention HIGH
39. Send programming instructions
 R } 10,000 kΩ range
 1 }
 E

- 40. Send addresses
 - ATN - Set Attention LOW
 - ? - Unlisten command
 - V - 3490A talk address
 - Address of listener
 - ATN - Set Attention HIGH
- 41. Accept 3490A reading
 - Check for 10,000 kΩ range
- 42. Send addresses
 - ATN - Set Attention LOW
 - ? - Unlisten command
 - 6 - 3490A listen address
 - Address of talker
 - ATN - Set Attention HIGH
- 43. Send programming instructions
 - M } Interrupt single with output
 - 7 }
 - E
- 44. Check for SRQ LOW after 3490A completes a reading
- 45. Send address and command
 - ATN - Set Attention LOW
 - V - 3490A talk address
 - Address of listener
 - (30₈) - Status Poll Enable command
 - ATN - Set Attention HIGH
- 46. Accept ASCII character from 3490A
 - Check if DIO7 is LOW
- 47. Send addresses
 - ATN - Set Attention LOW
 - ? - Unlisten command
 - 6 - 3490A listen address
 - Address of talker
 - ATN - Set Attention HIGH
- 48. Send programming instructions
 - M } Single reading with output
 - 3 }
 - E
- 49. Send address and command
 - ATN - Set Attention LOW
 - V - 3490A talk address
 - Address of listener
 - (30₈) - Status Poll Enable command
 - ATN - Set Attention HIGH
- 50. Accept ASCII character from 3490A
 - Check if DIO7 is HIGH
- 51. Send address and command
 - Universal untalk address
 - (31₈) - Status Poll Disable command

- 52. Return to local
 - REN - Set Remote Enable HIGH

5-47. General Test Procedure.

5-48. This procedure checks the ability of the 3490A HP-IB circuits to accept and process addressing and remote programming, and to output measurement data. This procedure may be used with any bus system controller.

5-49. Test Procedure Using Model 9820A Calculator.

5-50. This test sequence is written specifically for the -hp- Model 9820A Calculator, and performs the same operating checks as the general procedure in Paragraph 5-47. The 9820A must have the 11144A Interface and the Peripheral Control II ROM Block installed. Refer to the Operating Manuals for these instruments for operating instructions. The following test sequence may be recorded on an -hp- Calculator Program Card and used in subsequent tests and in troubleshooting. The program is presented in this procedure in the form that it is printed by the 9820A. The first statement gives an example of the 9820A keyboard sequence required.

Initialize the calculator and 3490A by pressing



Interface Clear, IFC, is LOW while STOP key is depressed)

Set REN to LOW.

```
0:
FMT Y3,Z;WRT 13F
```

The above sequence requires that the following keys be pressed

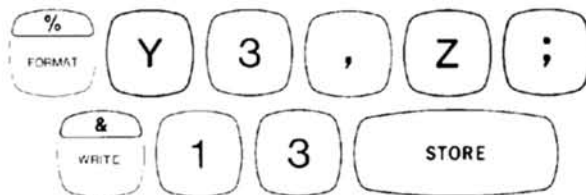

Set counter to 1.

```
1:
1 → B+
```

Address 3490A to listen, calculator to talk. 9820A talk address is U. This puts 3490A in remote control. Program 3490A to Test No. 1, Single Reading with Output, Immediate Internal Trigger.

```
2:
CMD "?6U"; "F3R7M
3T1E"␣
```

Address calculator to listen, 3490A to talk. Calculator listen address is 5. Accept 3490A reading.

```
3:
CMD "?V5"; FMT #;
RED 13; ␣␣
```

Instruct calculator to print reading, trigger 3490A, print the next reading, etc., until a total of 10 readings have been taken and printed, then go to 6.

```
4:
FXD 5; PRT A; IF B
=10; JMP 2␣
5:
1+B→B; CMD "?6U";
"E"; JMP -2␣
```

Address 3490A to listen, 9820A to talk. Program 3490A to DC function, 10 V range.

```
6:
CMD "?6U"; "F0R4E
"␣
```

Address 3490A to talk, 9820A to listen. Accept 3490A reading. Check for DC function.

```
7:
CMD "?V5"; RDB 13
+Z; RDB 13+Z; RDB
13+Z; IF Z=68;
PRT "DC"␣
```

Address 3490A to listen, 9820A to talk. Program 3490A to AC function.

```
8:
CMD "?6U"; "F2E"␣
```

Address 3490A to talk, 9820A to listen. Accept 3490A reading. Check for AC function.

```
9:
CMD "?V5"; RDB 13
+Z; RDB 13+Z; RDB
13+Z; IF Z=65;
PRT "AC"␣
```

Address 3490A to listen, 9820A to talk. Program Ohms function, .1 k Ω range.

```
10:
CMD "?6U"; "F1R6E
"; 1→␣␣
```

Address 3490A to talk, 9820A to listen. Accept 3490A reading. Check for KO function.

```
11:
CMD "?V5"; RDB 13
+Z; RDB 13+Z; RDB
13+Z; IF Z=75;
PRT "KO"␣
```

Instruct 9820A to check last character of output format (see Paragraph 3-47). Check for .1 k Ω range.

```
12:
RDB 13+Z; IF C≤10
; 1+C→C; JMP 0␣
13:
IF Z-48=6; PRT ".
1K"␣
```

Address 3490A to listen, 9820A to talk. Program 3490A to 1 k Ω range.

```
14:
CMD "?6U"; "R5E"␣
```

Address 3490A to talk, 9820A to listen.

```
15:
CMD "?V5"; 1→␣␣
```

Accept 3490A reading. Instruct 9820A to check last character of output format. Check for 1 k Ω range.

```
16:
RDB 13+Z; IF C≤13
; 1+C→C; JMP 0␣
17:
IF Z-48=5; PRT "1
K"␣
```

Address 3490A to listen, 9820A to talk. Program 3490A to 10 k Ω range.

```
18:
CMD "?6U"; "R4E"␣
```

Address 3490A to talk, 9820A to listen.

```
19:
CMD "?V5"; 1→␣␣
```

Accept 3490A reading. Instruct 9820A to check last character of output format. Check for 10 k Ω range.

```
20:
RDB 13+Z; IF C<13
;1+C+C; JMP 0F
21:
IF Z-48=4; PRT "1
00K" F
```

Address 3490A to listen, 9820A to talk. Program 3490A to 100 k Ω range.

```
22:
CMD "?6U", "R3E" F
```

Address 3490A to talk, 9820A to listen.

```
23:
CMD "?V5"; 1+CF
```

Accept 3490A reading. Instruct 9820A to check last character of output format. Check for 100 k Ω range.

```
24:
RDB 13+Z; IF C<13
;1+C+C; JMP 0F
25:
IF Z-48=3; PRT "1
00K" F
```

Address 3490A to listen, 9820A to talk. Program 3490A to 1000 k Ω range.

```
26:
CMD "?6U", "R2E" F
```

Address 3490A to talk, 9820A to listen.

```
27:
CMD "?V5"; 1+CF
```

Accept 3490A reading. Instruct 9820A to check last character of output format. Check for 1000 k Ω range.

```
28:
RDB 13+Z; IF C<13
;1+C+C; JMP 0F
29:
IF Z-48=2; PRT "1
000K" F
```

Address 3490A to listen, 9820A to talk. Program 3490A to 10,000 k Ω range.

```
30:
CMD "?6U", "R1E" F
```

Address 3490A to talk, 9820A to listen.

```
31:
CMD "?V5"; 1+CF
```

Accept 3490A reading. Instruct 9820A to check last character of output format. Check for 10,000 k Ω range.

```
32:
RDB 13+Z; IF C<13
;1+C+C; JMP 0F
33:
IF Z-48=1; PRT "1
0,000K" F
```

Address 3490A to listen, 9820A to talk. Program 3490A operating mode to Interrupt Single with Output.

```
34:
CMD "?6U", "M7E" F
```

Check SRQ, Service Request line. If line is LOW, go to 36.

```
35:
RDS 13+A; JMP A<1
F
```

Address 3490A to talk, 9820A to listen. Send Status Poll Enable. Check 3490A response to SPE on data line DIO7.

```
36:
CMD "V5:8"; RDB 1
3+B; IF B>63; PRT
"LDIO7 IS LOW" F
```

Address 3490A to listen, 9820A to talk. Program 3490A operating mode to Single Reading with Output.

```
37:
CMD "?6U", "M3E" F
```

Address 3490A to talk, 9820A to listen. Send Status Poll Enable. Check 3490A response to SPE on data line DIO7.

```
38:
CMD "V5:8"; RDB 1
3+C; IF C<63; PRT
"LDIO7 IS HIGH" F
```

Send universal untalk address and Status Poll Disable command.

```
39:
CMD "?+29" F
```

Set REN line to HIGH and end program.

```
40:
FMT Y4,Z; WRT 13F
41:
END F
```

5-51. ADJUSTMENT PROCEDURES.

5-52. Complete adjustment procedures for the Model 3490A Multimeter, including options, are contained in the following paragraphs. These procedures should be performed only after it has been determined from the Performance Tests that the 3490A is out of adjustment. The adjustments in Paragraphs 5-53 through 5-60 must be performed in the order given, and before the ac, ohm, sample/hold and ratio adjustments. If any adjustment cannot be made correctly, refer to the Troubleshooting Procedures in Section VII. Location of adjustments in the standard instrument is shown in Figure 5-9, Sample/ Hold adjustments in Figure 5-10, and Ratio adjustments in Figure 5-11. All adjustments are shown on the top guard cover. Turn the 3490A on and allow it to warm up for at least 4 hours with the covers on before performing the adjustment procedures. The top cover must be removed to gain access to the adjustments, which should be made with the guard (inner) cover on.

WARNING

The inner cover is at Guard potential. Use caution to prevent shock when high voltages are connected to the Input.

5-53. POWER SUPPLY ADJUSTMENT.

5-54. A dc digital voltmeter with 4-digit resolution and an oscilloscope are required for this adjustment.

a. Connect digital voltmeter and oscilloscope between the + 17 V test point on A1A1 and the input Low terminal.

c. Set the sample rate on HOLD and measure the ripple present with the oscilloscope. If the voltages specified in Table 5-9 cannot be met, refer to Section VII, Troubleshooting and Circuit Diagrams.

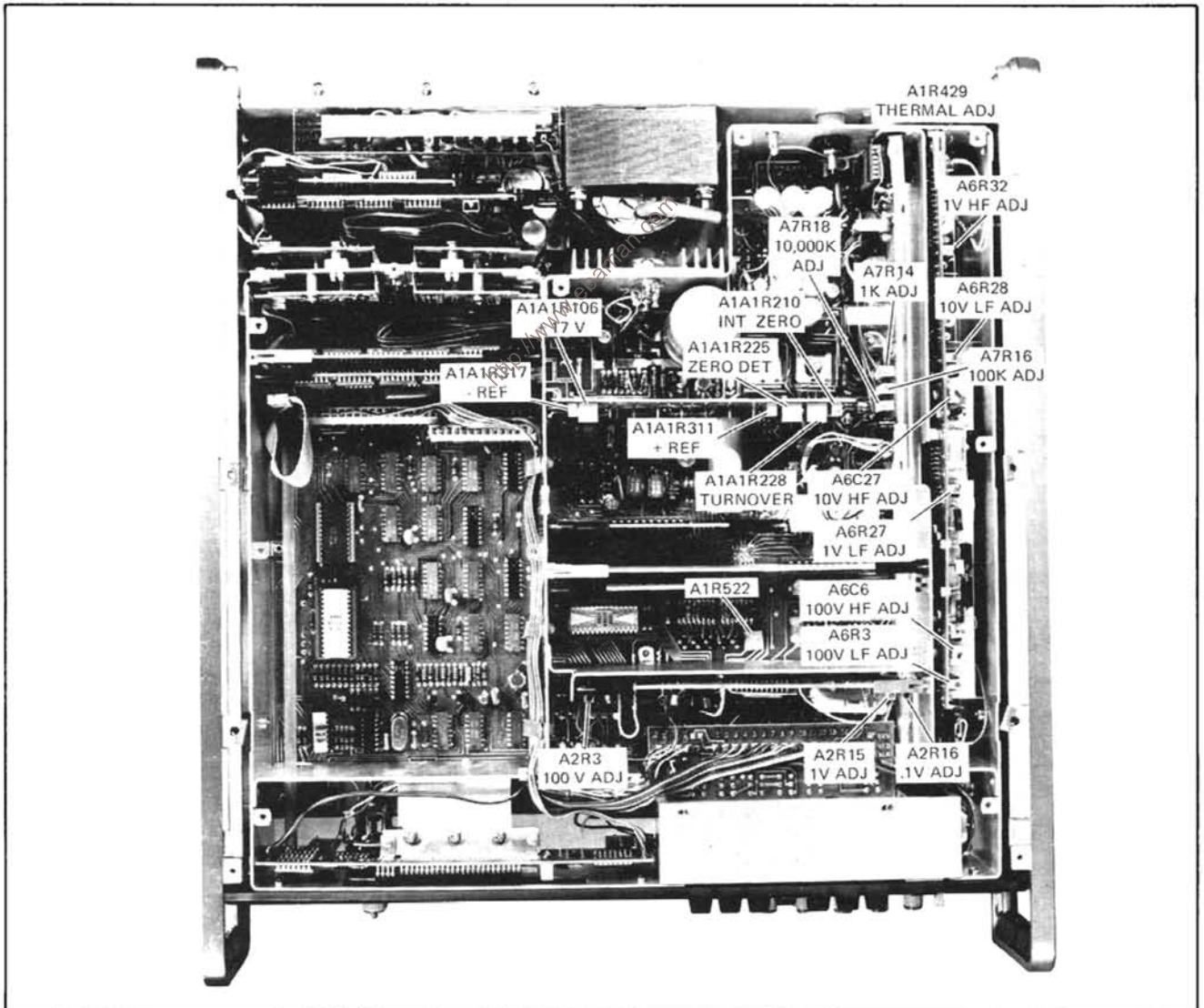

Figure 5-9. Location of Adjustments, Standard 3490A.

d. Check other power supply voltages by connecting digital voltmeter and oscilloscope to test points listed in Table 5-9. If any voltage is not correct, refer to Section VII.

Table 5-9. Power Supply Voltages.

A1A1 Test Point	Voltage	Ripple*
+ 17 V	+ 16.99 to + 17.01 V	< 50 mV p-p
+ 5 V	+ 4.995 to + 5.075 V	< 60 mV p-p
+ 30 V	+ 30.10 to + 30.90 V	< 25 mV p-p
- 17 V	- 16.925 to - 17.175 V	< 50 mV p-p
- 5 V	- 5.00 to - 5.85 V	< 60 mV p-p
- 30 V	- 30.10 to - 30.90 V	< 25 mV p-p

*All ripple measurements are with the Sample Rate on HOLD.

5-55. DC ZERO ADJUSTMENTS.

5-56. A dc standard (-hp- 740B) and a dc voltmeter able to resolve 10 μ V are required for these adjustments.

a. Connect dc voltmeter between A1A1 test point A and input Low terminal.

b. Set 3490A SAMPLE RATE control fully counter-clockwise to HOLD position.

c. Adjust A1A1R210 (Int Zero) for voltmeter reading of $0 \pm 150 \mu$ V. Disconnect voltmeter.

d. Set FUNCTION to DC, RANGE to 10 V, SAMPLE RATE to FAST.

e. Connect dc standard to 3490A input and adjust standard output to + 0.00100 V.

f. Adjust A1A1R225 (Zero Detect Level) for maximum reading on 3490A display. Note reading.

g. Reverse polarity of input and adjust A1A1R228 (Turnover) for reading noted in step f. Continue reversing input polarity and adjusting A1A1R228 until positive and negative readings are equal.

h. Apply + 0.00100 V input to 3490A. Adjust A1A1R225 (Zero Detect Level) for 3490A display of + 00.0010.

5-57. REFERENCE ADJUSTMENTS.

5-58. A dc standard (-hp- 740B) is required for these adjustments.



Guard Terminal should be connected to Low or damage to the instrument may result.

a. Set 3490A FUNCTION to DC, RANGE to 10 V.

b. Connect dc standard to 3490A input and adjust standard output to - 10.0000 V.

c. Adjust A1A1R311 (+ Ref) for 3490A display of - 10.0000.

d. Set 3490A FUNCTION to TEST, RANGE to 3. Adjust A1A1R317 (- REF) so that positive and negative display readings are equal within 1 count. Last digit must be between 2 and 9 (0.9999x). If not, repeat steps a through d. Disconnect dc standard.

5-59. DC AMPLIFIER ADJUSTMENTS.

5-60. A dc standard (-hp- 740B) is required for these adjustments.

a. Set 3490A FUNCTION to DC, RANGE to .1 V. Short input terminals with a copper bar or heavy solid copper wire.

b. Adjust A1R429, accessible through hole in rear panel, for 3490A display of $0 \pm .000002$.

c. Set 3490A RANGE to 1 V.

d. Remove short from input terminals and connect dc standard. Adjust standard output to - 1.000000 V.

e. Adjust A2R15 (1 V Adj) for 3490A display of - 1.00000.

f. Set 3490A RANGE to 100 V, and adjust dc standard output to - 100.000 V.

g. Adjust A2R3 (100 V Adj) for 3490A display of - 100.000. Reduce dc standard output and disconnect.

h. Set 3490A FUNCTION to TEST, RANGE to 6. Short input terminals and note amount and polarity of offset reading.

i. Remove short and apply - 10.0000 V input. Adjust A2R16 (0.1 V Adj) for display of - 1000.00, minus (algebraically subtracting) the offset noted in step h.

5-61. AC CONVERTER ADJUSTMENTS.

5-62. Adjustment of the dc circuits, Paragraphs 5-53 through 5-60, must be completed before beginning this procedure. An ac calibrator (-hp- 745A) with a correction factor chart is required for these adjustments. Guard covers must be in place for this procedure.

5-63. 1 V Range Adjustments.

a. Set 3490A FUNCTION to AC, RANGE to 1 V.

b. Connect ac calibrator to 3490A input. Set calibrator output to 1.000000 V at 100 kHz (using correction factor chart as necessary).

c. Adjust A6R32 (1 V HF Adj) for 3490A display of 1.00000.

d. Change ac calibrator frequency to 100 Hz and adjust A6R27 (1 V LF Adj) for display of 1.00000.

e. Repeat steps c and d until both readings are correct.

5-64. 10 V Range Adjustments.

a. Set 3490A RANGE to 10 V.

b. Set ac calibrator output to 10.00000 V at 100 Hz.

c. Adjust A6R28 (10 V LF Adj) for display of 10.0000.

d. Change ac calibrator frequency to 100 kHz and adjust A6C27 (10 V HF Adj) for display of 10.0000. If maximum limit of adjustment is less than 10.0000, remove jumper wire in series with A6C28. If minimum limit of adjustment is greater than 10.0000, jumper wire probably has been removed and should be replaced.

e. Repeat steps c and d until both readings are correct.

5-65. 100 V Range Adjustments.

a. Set 3490A RANGE to 100 V.

b. Set ac calibrator output to 100.0000 V at 100 Hz.

c. Adjust A6R3 (100 V LF Adj) for display of 100.000.

d. Change ac calibrator frequency to 100 kHz and adjust A6C6 (100 V HP Adj) for display of 100.000. If maximum limit of adjustment is less than 100.000, remove jumper wire in series with A6C4. If minimum limit of adjustment is greater than 100.000, jumper wire probably has been removed and should be replaced.

e. Repeat steps c and d until both readings are correct.

5-66. OHMMETER ADJUSTMENTS.

5-67. Adjustment of the dc circuits, Paragraphs 5-53 through 5-60, must be completed before beginning this procedure. A resistance decade with a correction factor chart (GR 1433-Z) is required for the following procedure. If a suitable resistance decade is not available, refer to Paragraph 5-68. The error indicated by the correction factor chart should be taken into account when adjusting the ohms converter. For example, if the resistance of the decade is high at 1 k Ω , the 3490A display should be adjusted to 1.00000 plus the resistance decade error.

a. Set FUNCTION to TEST, RANGE to 7. Short Ω Signal terminals. Adjust A7R5 for display of -9700.0 \pm 100.0 (Instruments with serial numbers below 1211A00656 may not have this adjustment.)

b. Set 3490A FUNCTION to Ω , RANGE to 1 k.

c. Connect resistance decade to 3490A Input and Ω Signal terminals. Connect 3490A Guard to Input Low, and decade Guard terminal to Low terminal.

d. Set decade resistance to 1 k Ω and adjust A7R14 (1 k Adj) for display of 1.00000 (\pm decade resistance error).

e. Set 3490A RANGE to 100 k.

f. Set decade resistance to 100 k Ω and adjust A7R16 (100 k Adj) for display of 100.000 (\pm decade resistance error).

g. Set 3490A RANGE to 10,000 k.

h. Set decade resistance to 10 M Ω and adjust A7R18 (10,000 k Adj) for display of 10000.0 (\pm decade resistance error).

5-68. If an accurate resistance decade is not available, adjustment of the ohms converter may be made using resistors within 10% of the full-range value of 1 k Ω , 100 k Ω or 10 M Ω , whose resistances are known to within a close tolerance. Table 5-10 shows the resistance values and the tolerances required for valid adjustment. The proper adjustment should be made so that the 3490A display reads the known value of the resistor. Perform step a of Paragraph 5-67 before making adjustments in Table 5-10.

5-69. SAMPLE/HOLD ADJUSTMENTS.

5-70. Adjustment of the dc circuits, Paragraphs 5-53 through 5-60, must be completed before beginning the Sample/Hold adjustments. The following adjustments must be performed in the order given. Figure 5-10 shows the location of the Sample/Hold adjustments. They are also shown on the top guard cover.

5-71. Offset Gain Adjustment.

5-72. A dc digital voltmeter having a resolution of 10 μ V is required for this procedure, which adjusts the gain of the Offset Amplifier.

Table 5-10. Ohmmeter Adjustment.

3490A Range	Resistance		3490A Adjustment
	Value	Tolerance	
1 k Ω	900 Ω to 1.1 k Ω	\pm 0.0025%	A7R14
100 k Ω	90 k Ω to 110 k Ω	\pm 0.0025%	A7R16
10,000 k Ω	9M Ω to 11 M Ω	\pm 0.01%	A7R18

- a. Remove the top guard cover.
- b. Locate the white/black wire just to the rear of the display cable connector. This wire is labeled "5th Digit Blank" in Figure 5-10. Disconnect this wire from Test Point L and connect to Test Point M. This restores the display to five full digits for Sample/Hold measurements, providing greater resolution in order to make the following adjustments more accurately.
- c. Set 3490A FUNCTION to DC, RANGE to 10 V, SAMPLE/HOLD to TRACK/HOLD, SAMPLE RATE to HOLD. Short input High to Low.
- d. Connect digital voltmeter between A27TP3 and ground test point on A1A1. Record voltage reading.
- e. Connect jumper wire between Test Point LTST on A28 and ground.
- f. Set SAMPLE/HOLD switch to OFF, then back to TRACK/HOLD.
- g. Adjust A27R14, Gain Adjust, for digital voltmeter reading the same as that noted in step d \pm 0.0005 V.
- h. Disconnect digital voltmeter and remove jumper wire between LTST and ground.
- i. Replace top guard cover and secure with only two screws.

5-73. Offset Adjustment.

5-74. This procedure adjusts the Offset Amplifier so that there is no turnover error between positive and negative inputs. A dc standard (-hp- 740B) is required.

- a. With 3490A set to 10 VDC RANGE, TRACK/HOLD, and input shorted as in previous adjustment, set SAMPLE RATE fully clockwise.
- b. Adjust A27R13, Offset, for 3490A display of zero \pm 0.0001 V.
- c. Disconnect input short and connect dc standard to input terminals. Set standard output to +10.0000 V. Note 3490A reading.
- d. Reverse polarity of input (to -10.0000 V) and note reading. Disregarding polarity display, adjust A27R13 to split the difference between the readings in step c and step d.
- e. Continue reversing input polarity and adjusting A27R13 until there is no numerical difference between readings with positive and negative inputs.

5-75. Dielectric Absorption Adjustment.

5-76. A dc standard (-hp- 740B) is required for this procedure, which adjusts the dielectric absorption compensation.

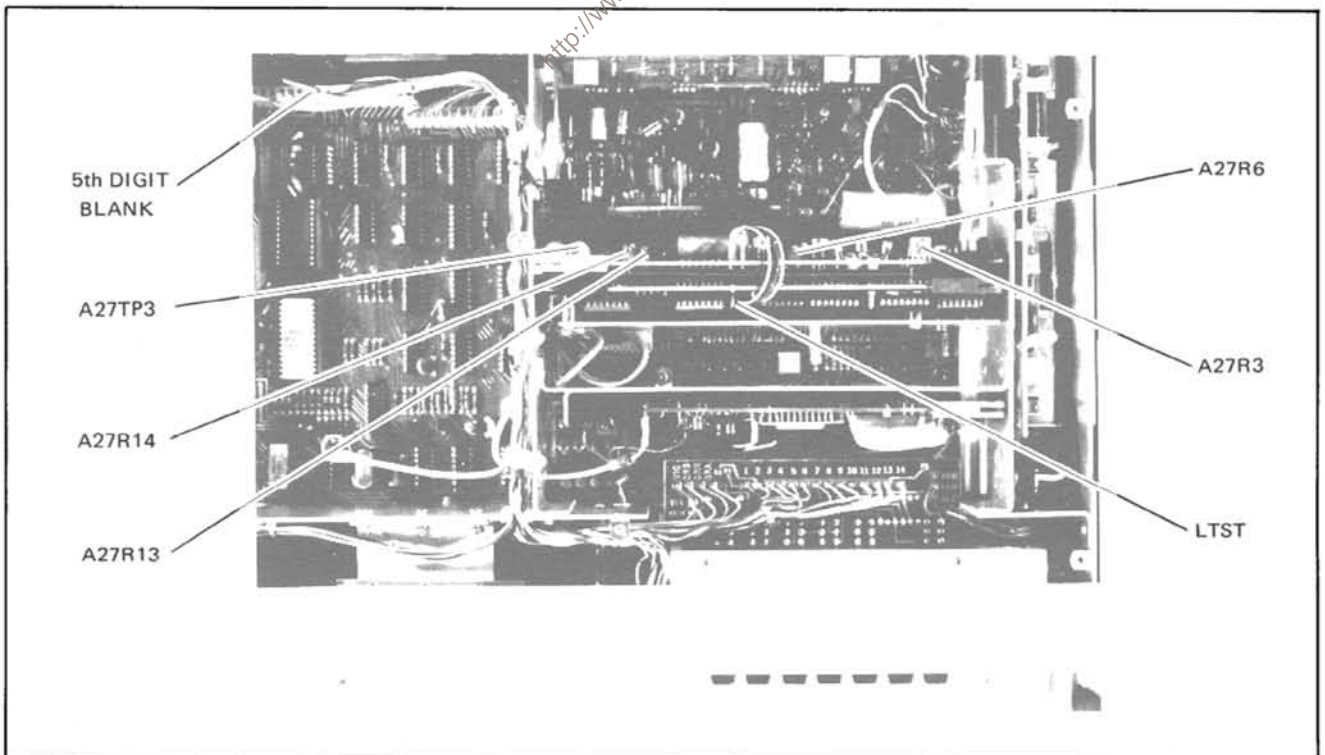

Figure 5-10. Location of Sample/Hold Adjustments.

a. With 3490A set to 10 VDC RANGE, TRACK/HOLD, SAMPLE RATE fully clockwise, and dc standard connected to input as in previous adjustment, set dc standard output to + 10.0000 V.

b. Adjust A27R6, DA Gain, for display of + 10.0000 V. (Display will be noisy.)

5-77. Response Adjustment.

5-78. This procedure requires a function generator (-hp-3310A), a silicon diode, a 10 k Ω resistor and an oscilloscope having a delayed sweep and a delayed gate output (-hp-180C/D/1081A/1821A). The delayed gate output must be a negative-going pulse with an amplitude of 2 to 200 V and a width of at least 30 nanoseconds.

a. Connect equipment as shown in Figure 5-7. If the 3490A has BCD/Remote Expand Option 020, also connect Stretched Pulse Output (J7 pin 10) to External Encode (J7 pin 28).

b. With 3490A set to 10 VDC RANGE and TRACK/HOLD as in previous adjustment, set SAMPLE RATE to HOLD.

c. Set oscilloscope controls for External Trigger, negative slope and Main sweep. Set Main sweep to .1 ms/div., Delayed sweep to 1 μ s/div.

d. Set function generator to square wave, frequency to 1 kHz, and adjust output level for 20 V peak-to-peak signal as displayed on oscilloscope.

e. Adjust oscilloscope delay control so that intensified trace begins approximately 450 μ s after negative-going transition of square wave. Note 3490A reading, which should be near zero.

f. Adjust delay so that intensified trace begins approximately 120 μ s after negative-going edge of square wave.

g. Adjust A27R3, Response, for display noted in step e.

h. Remove top guard cover and move "5th Digit Blank" wire from Test Point M to Test Point L.

i. Replace and secure top guard cover.

5-79. RATIO REFERENCE ADJUSTMENTS.

5-80. Adjustment of the dc circuits, Paragraphs 5-53 through 5-60, must be completed before beginning the Ratio Reference Adjustments. A dc standard (-hp-740B), a 1 M \pm 10% resistor (-hp-0698-1051) and a stable voltage source between 9.5 V and 10.5 V, such as a mercury battery (Mallory TR177), are required for these adjustments. Figure 5-11 shows the location of the Ratio adjustments. They are also shown on the top guard cover.

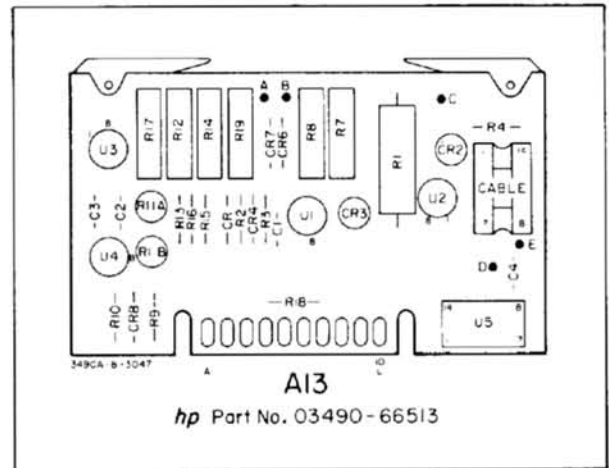

Figure 5-11. Location of Ratio Adjustments.

a. Set 3490A FUNCTION to TEST, RANGE to 4. Set RATIO switch to EXT REF 10 V. Connect short between EXT REF High and Low terminals.

b. Connect dc standard to INPUT terminals and adjust standard output to + 10.0000 V. If the display indicates Overload, reverse the polarity of the dc standard output.

NOTE

Steps c and d adjust the zero setting of the External Reference Amplifier and the Feedback Amplifier. With the 3490A set to Test 4, the integrator charges to the External Reference Amplifier output and discharges to the \pm 10.0000 V input. If the zero adjustments are set so that the amplifier output and the 3490A input voltage are the same polarity, the display indicates Overload.

c. Adjust A13R17 (Offset 3) for zero display. If the display goes to Overload, reverse polarity of dc standard output and slowly adjust A13R17 in opposite direction for zero display. Continue adjusting A13R17 with positive and negative 10.0000 V inputs until display reads zero \pm 0.0001 V for either polarity input.

d. Set RATIO switch to EXT REF 1 V. Adjust A13R8 (Offset 1) with positive and negative 10.0000 V inputs for display of zero \pm 0.0001 V.

e. Repeat steps c and d until display is zero \pm 0.0001 V for both positive and negative inputs on both 1 V and 10 V EXT REF ranges.

f. Remove short and connect 1 M Ω resistor to EXT REF terminals.

g. Set **RATIO** switch to **EXT REF 1 V**. Adjust A13R7 (Bias. Adj.) with both positive and negative 10.0000 V inputs for display of zero \pm 0.0005 V.

h. Repeat steps a through g until all readings are correct.

i. Disconnect 1 M Ω resistor from **EXT REF** terminals. Set **RATIO** switch to **INT REF**, **FUNCTION** to **DC**, **RANGE** to **10 V**.

j. Connect a mercury battery between 9.5 V and 10.5 V, or other floating voltage source stable within 1 mV/hr, to **INPUT** terminals, - to **High**, + to **Low**. Note 3490A reading.

k. Connect dc standard to **EXT REF** terminals and set standard output to positive voltage equal to negative reading in step j.

l. Set **RATIO** switch to **EXT REF 10 V**. Note 3490A display.

m. Reverse the polarity of the voltage at both the **INPUT** and the **EXT REF** terminals. Adjust A13R7, repeating steps k through l until the reading in step l is equal to the reading in step m. (Polarity should be - for both readings.)

n. Reduce **EXT REF** voltage to 1/10 the voltage selected in step k. Set **RATIO** switch to **EXT REF 1 V**. With mercury battery connected to **INPUT**, - to **HIGH**, + to **LOW**, note 3490A display.

o. Reverse the polarity of the voltage at both the **INPUT** and the **EXT REF** terminals. Adjust A13R8, repeating steps n and o until the reading in step o is equal to the reading in step n. (Polarity should be - for both readings.)

p. Repeat steps j through o until all readings are correct.

q. Connect mercury battery to **INPUT** terminals, - to **HIGH**, + to **LOW**.

r. Connect dc standard to **EXT REF** terminals and set standard output to positive voltage equal to negative reading in step j.

s. Set **RATIO** switch to **EXT REF 10 V**. Adjust A13R14 (10 V Adj) for display of - 10.0000.

t. Reduce **EXT REF** voltage to 1/10 the voltage selected in step k (positive). Set **RATIO** switch to **EXT REF 1 V**. Adjust A13R12 (1 V Adj) for display of - 10.0000.

u. Set **RATIO** switch to **INT REF**, **FUNCTION** to **TEST**, **RANGE** to **3**. This test alternates positive and negative readings. If the readings are not equal \pm 1 count and between \pm 0.99992 and \pm 0.99999, adjust A1A1R317 (- Ref) to obtain this condition. Record both readings (after adjustment).

v. Set **RATIO** switch to **EXT REF 10 V**. Apply - 10.0000 V to **EXT REF** terminals. Readings will alternate + and - as in previous step. Record positive reading.

w. Adjust A13R19 (Offset 301) for positive display equal to

$$\frac{(\text{positive reading, step u}) + (\text{positive reading, step v})}{2}$$

x. Adjust A1A1R317 for positive display equal to positive reading in step u.

y. Positive and negative displays should now be equal \pm 1 count, and equal to readings recorded in step n \pm 1 count, respectively. If not, repeat this adjustment procedure (steps a through x).

z. Perform DC Amplifier Adjustment, Paragraph 5-59.

NOTE

In order to operate the 3490A with the Ratio Assembly A13 removed and the Ratio Jumper Assembly A26 inserted in its place, it will be necessary to perform the Reference Adjustments, Paragraph 5-57.

PERFORMANCE TEST RECORD

Hewlett-Packard Model 3490A
Multimeter
Serial Number _____

Tests Performed by _____
Date _____

PARAGRAPH	DESCRIPTION			READING		TEST LIMITS	
5-9	DC Voltmeter Accuracy						
	Range	Input	Pos.	Neg.	Min.	Max.	
	.1 V	± 0.01000 V	_____	_____	.009995	.010005	
		± 0.05000 V	_____	_____	.049990	.050010	
		± 0.10000 V	_____	_____	.099985	.100015	
	1 V	± 0.10000 V	_____	_____	0.09997	0.10003	
		± 0.50000 V	_____	_____	0.49994	0.50006	
		± 1.00000 V	_____	_____	0.99990	1.00010	
	10 V	± 1.00000 V	_____	_____	00.9997	01.0003	
		± 10.0000 V	_____	_____	09.9990	10.0010	
	100 V	± 10.0000 V	_____	_____	009.997	010.003	
		± 100.000 V	_____	_____	099.990	100.010	
	1000 V	± 100.000 V	_____	_____	0099.97	0100.03	
		± 500.000 V	_____	_____	0499.92	0500.08	
		+ 1000.00 V	_____	_____	0999.86	1000.14	
5-11	AC Voltmeter Accuracy						
	Range	Input	Freq.				
	1 V	1 V	20 Hz	_____	0.99600	1.00400	
		1 V	10 kHz	_____	0.99875	1.00125	
		1 V	100 kHz	_____	0.99875	1.00125	
	10 V	1 V	100 kHz	_____	00.9965	01.0035	
		5 V	20 kHz	_____	04.9925	05.0075	
		10 V	20 Hz	_____	09.9600	10.0400	
	100 V	10 V	100 Hz	_____	009.965	010.035	
		100 V	50 kHz	_____	099.875	100.125	
	1000 V	1000 V	10 kHz	_____	0998.65	1001.35	
		1000 V	100 Hz	_____	0998.75	1001.25	
	1 V	1 V	250 kHz	_____	0.99190	1.00810	
	10 V	3 V	250 kHz	_____	02.9715	03.0285	
5-15	Ohmmeter Accuracy						
	Range	Input			Min.	Max.	
	.1 kΩ	100 Ω	_____	_____	.099983	.100017	
	1 kΩ	1 kΩ	_____	_____	0.99988	1.00012	
	10 kΩ	10 kΩ	_____	_____	09.9988	10.0012	
	100 kΩ	100 kΩ	_____	_____	099.988	100.012	
	1000 kΩ	1 MΩ	_____	_____	0999.86	1000.14	
	10,000 kΩ	10 MΩ	_____	_____	09996.3	10003.7	
5-20	DC Common-Mode Rejection			_____	-	0.00005	
5-22	AC Common-Mode Rejection			_____	-	00.0001	
5-24	AC Normal-Mode Rejection			_____	-	00.0316	
5-26	DC Voltmeter Input Resistance						
	10 V Range		_____	_____	-	00.0010	
	100 V Range		_____	_____	000.908	000.910	
5-28	AC Voltmeter Input Impedance						
	Without Rear Terminal						
	25 Hz		_____	_____	0.65975	-	
	250 kHz		_____	_____	0.49211	-	
	With Rear Terminal						
	25 Hz		_____	_____	0.65804	-	
	250 kHz		_____	_____	0.41321	-	

PERFORMANCE TEST RECORD (CONT'D)

PARAGRAPH	DESCRIPTION		READING		TEST LIMITS		
5-32	Sample/Hold DC Accuracy						
	Track/Hold						
	Range	Input	Pos.	Neg.	Min.	Max.	
	1 V	± 0.10000 V	_____	_____	± 0.0998	0.1002	
	1 V	± 0.50000 V	_____	_____	± 0.4998	0.5002	
	1 V	± 1.00000 V	_____	_____	± 0.9997	1.0003	
	10 V	± 1.00000 V	_____	_____	± 00.998	01.002	
	10 V	± 5.00000 V	_____	_____	± 04.998	05.002	
	10 V	± 10.0000 V	_____	_____	± 09.997	10.003	
	100 V	± 10.0000 V	_____	_____	± 009.98	010.02	
	100 V	± 50.0000 V	_____	_____	± 049.98	050.02	
	100 V	± 100.000 V	_____	_____	± 099.97	100.03	
	1000 V	± 100.000 V	_____	_____	± 0099.8	0100.2	
	1000 V	± 500.000 V	_____	_____	± 0499.8	0500.2	
	1000 V	± 1000.00 V	_____	_____	± 0999.7	1000.3	
	Acquire/Hold						
	1 V	± 0.10000 V	_____	_____	± 0.0998	0.1002	
	1 V	± 0.50000 V	_____	_____	± 0.4998	0.5002	
	1 V	± 1.00000 V	_____	_____	± 0.9997	1.0003	
	10 V	± 1.00000 V	_____	_____	± 00.998	01.002	
	10 V	± 5.00000 V	_____	_____	± 04.998	05.002	
	10 V	± 10.0000 V	_____	_____	± 09.997	10.003	
	100 V	± 10.0000 V	_____	_____	± 009.98	010.02	
	100 V	± 50.0000 V	_____	_____	± 049.98	050.02	
	100 V	± 100.000 V	_____	_____	± 099.97	100.03	
	1000 V	± 100.000 V	_____	_____	± 0099.8	0100.2	
	1000 V	± 500.000 V	_____	_____	± 0499.8	0500.2	
	1000 V	± 1000.00 V	_____	_____	± 0999.7	1000.3	
	5-34	Sample/Hold Response					
		10 V range, 1 kHz	_____	_____	_____	± 0.001 V	
1 V range, 200 Hz		_____	_____	_____	± 0.001 V		
5-38	DC/DC Ratio Accuracy						
	Preferred Method						
	Ext Ref Range	Ext Ref Voltage	Input Range	Input Voltage	Reading	Min. Max.	
	1 V	+ 0.10000 V	1 V	+ 0.10000 V	_____	+ 0.99955 + 1.00045	
	1 V	+ 0.50000 V	1 V	+ 0.50000 V	_____	+ 0.99979 + 1.00021	
	1 V	+ 1.00000 V	1 V	+ 1.00000 V	_____	+ 0.99982 + 1.00018	
	1 V	+ 1.00000 V	1 V	- 1.00000 V	_____	- 0.99982 - 1.00018	
	1 V	- 1.00000 V	1 V	- 1.00000 V	_____	+ 0.99982 + 1.00018	
	1 V	- 1.00000 V	1 V	+ 1.00000 V	_____	- 0.99982 - 1.00018	
	1 V	+ 1.20000 V	1 V	+ 1.00000 V	_____	+ 0.83316 + 0.83350	
	10 V	+ 1.00000 V	10 V	+ 1.00000 V	_____	+ 09.9955 + 10.0045	
	10 V	+ 5.00000 V	10 V	+ 5.00000 V	_____	+ 09.9979 + 10.0021	
	10 V	+ 10.0000 V	100 V	+ 100.000 V	_____	+ 099.979 + 100.021	
	10 V	+ 12.0000 V	100 V	+ 100.000 V	_____	+ 083.313 + 083.353	
	Alternate Method						
	Ext Ref Range			Pos.	Neg.		
	10 V			_____	_____	09.9982 10.0018	
	1 V			_____	_____	09.9982 10.0018	

PERFORMANCE TEST RECORD (CONT'D)

PARAGRAPH	DESCRIPTION				READING	TEST LIMITS	
5-41	AC/DC Ratio Accuracy						
	Ext Ref Range	Ext Ref Voltage	Input Range	Input Voltage		Max.	Min.
	1 V	0.50000 V	1 V	0.50000 V	_____	0.99865	1.00135
	1 V	1.00000 V	1 V	1.00000 V	_____	0.99865	1.00135
	1 V	1.20000 V	1 V	1.00000 V	_____	0.83218	0.83448
	10 V	1.00000 V	10 V	1.00000 V	_____	09.9865	10.0135
	10 V	5.00000 V	10 V	5.00000 V	_____	09.9865	10.0135
	10 V	10.0000 V	10 V	10.0000 V	_____	09.9865	10.0135
	10 V	12.0000 V	10 V	10.0000 V	_____	08.3218	08.3448
5-43	External Reference Input Resistance Test				_____	100 counts change	

<http://www.ebaman.com>

SECTION VI

REPLACEABLE PARTS

6-1. INTRODUCTION.

6-2. This section contains information for ordering replaceable parts. Table 6-1 lists parts in alphabetic order of their reference designators and indicates the description, -hp- part number of each part, together with any applicable notes and provides the following:

- a. Total quantity used in the instrument (Qty column). The total quantity of a part is given the first time the part number appears.
- b. Description of the part. (See list of abbreviations below.)
- c. Typical manufacturer of the part in a five-digit code. (See Appendix A for list of manufacturers.)
- d. Manufacturers part number.

6-3. Miscellaneous parts are listed at the end of Table 6-1.

6-4. ORDERING INFORMATION.

6-5. To obtain replacement parts, address order or inquiry to your local Hewlett-Packard Field Office. (See Appendix B for list of office locations.) Identify parts by their Hewlett-Packard part numbers. Include instrument model and serial numbers.

6-6. NON-LISTED PARTS.

6-7. To obtain a part that is not listed, include:

- a. Instrument model number.
- b. Instrument serial number.
- c. Description of the part.
- d. Function and location of the part.

6-8. PROPRIETARY PARTS.

6-9. Items marked by a dagger (†) in the reference designator column are available only for repair and service of Hewlett-Packard instruments.





















ABBREVIATIONS											
Ag	silver	Hz	hertz (cycle(s) per second)	NP	negative positive zero (zero temperature coefficient)	sl	slide	SPDT	single-pole double-throw	Ta	tantalum
Al	aluminum	ID	inside diameter	ns	nanosecond(s) = 10 ⁻⁹ seconds	SPST	single-pole single-throw	TiO ₂	titanium dioxide	TC	temperature coefficient
A	ampere(s)	imp	impregnated	nsr	not separately replaceable	tol	tolerance	log	toggle	trim	trimmer
Au	gold	incd	incandescent	Ω	ohm(s)	TSTR	transistor	var	variable	v	volt(s)
C	capacitor	ins	insulated	obd	order by description	wacw	alternating current working voltage	vw	with	vacw	vacuum tube, neon bulb, photocell, etc.
cer	ceramic	kΩ	kiloohm(s) = 10 ³ ohms	OD	outside diameter	wv	working inverse voltage	w/o	without	vw	wirewound
coef	coefficient	KHz	kiloohm(s) = 10 ³ hertz	p	peak	w/w	with	ww	without	W	watt(s)
com	common	L	inductor	pA	picoampere(s)	w/w	with	ww	without	W	watt(s)
comp	composition	lin	linear taper	pc	printed circuit	w/w	with	ww	without	W	watt(s)
conn	connection	log	logarithmic taper	pF	picofarad(s) = 10 ⁻¹² farads	w/w	with	ww	without	W	watt(s)
dep	deposited	mA	milliampere(s) = 10 ⁻³ amperes	piv	peak inverse voltage	w/w	with	ww	without	W	watt(s)
DPDT	double-pole double-throw	MHz	megahertz = 10 ⁶ hertz	p/o	part of	w/w	with	ww	without	W	watt(s)
DPST	double-pole single-throw	MΩ	megohm(s) = 10 ⁶ ohms	pos	position(s)	w/w	with	ww	without	W	watt(s)
elect	electrolytic	met flm	metal film	poly	polystyrene	w/w	with	ww	without	W	watt(s)
encap	encapsulated	mfr	manufacturer	pot	potentiometer	w/w	with	ww	without	W	watt(s)
F	farad(s)	mtg	mounting	p-p	peak-to-peak	w/w	with	ww	without	W	watt(s)
FET	field effect transistor	ms	millisecond	ppm	parts per million	w/w	with	ww	without	W	watt(s)
fxd	fixed	mV	millivolt(s) = 10 ⁻³ volts	prec	precision (temperature coefficient, long term stability and/or tolerance)	w/w	with	ww	without	W	watt(s)
GaAs	gallium arsenide	μF	microfarad(s)	R	resistor	w/w	with	ww	without	W	watt(s)
GHz	gigahertz = 10 ⁹ hertz	μs	microsecond(s)	Rh	rhodium	w/w	with	ww	without	W	watt(s)
gd	guard(ed)	μV	microvolt(s) = 10 ⁻⁶ volts	rms	root-mean-square	w/w	with	ww	without	W	watt(s)
ge	germanium	my	Mylar®	rot	rotary	w/w	with	ww	without	W	watt(s)
gnd	ground(ed)	nA	nanoampere(s) = 10 ⁻⁹ amperes	Se	selenium	w/w	with	ww	without	W	watt(s)
H	henry(ies)	NC	normally closed	sect	section(s)	w/w	with	ww	without	W	watt(s)
Hg	mercury	Ne	neon	Si	silicon	w/w	with	ww	without	W	watt(s)
		NO	normally open			w/w	with	ww	without	W	watt(s)

DECIMAL MULTIPLIERS					
Prefix	Symbols	Multiplier	Prefix	Symbols	Multiplier
tera	T	10 ¹²	centi	c	10 ⁻²
giga	G	10 ⁹	milli	m	10 ⁻³
mega	M or Meg	10 ⁶	micro	μ	10 ⁻⁶
kilo	K or k	10 ³	nano	n	10 ⁻⁹
hecto	h	10 ²	pico	p	10 ⁻¹²
deka	da	10	femto	f	10 ⁻¹⁵
deci	d	10 ⁻¹	atto	a	10 ⁻¹⁸

DESIGNATORS											
A	assembly	FL	filter	Q	transistor	TS	terminal strip	U	microcircuit		
B	motor	HR	heater	OCR	transistor-diode	V	vacuum tube, neon bulb, photocell, etc.	W	wirewound		
BT	battery	IC	integrated circuit	R	resistor	X	socket	W	watt(s)		
C	capacitor	J	jack	RT	thermistor	X	socket	X	socket		
CR	diode	K	relay	S	switch	X	socket	X	socket		
DL	delay line	L	inductor	T	transformer	XDS	lampholder	X	socket		
DS	lamp	M	meter	TB	terminal board	XF	fuseholder	X	socket		
E	misc electronic part	MP	mechanical part	TC	thermocouple	Y	crystal	X	socket		
F	fuse	P	plug	TP	test point	Z	network	X	socket		

STD-B-2734



Table 6-1. Replaceable Parts

Reference Designation	HP Part Number	Qty	Description	Mfr Code	Mfr Part Number	
A1	03490-66551  	1	MAIN CIRCUIT BOARD ASSY	78480	03490-66541	
A1C1	0150-0093	26	C:FXD CER 0.01 UF +80-20% 100VDCW	72982	801-K800011	
A1C2	0150-0093		C:FXD CER 0.01 UF +80-20% 100VDCW	72982	801-K800011	
A1C3	0150-0093		C:FXD CER 0.01 UF +80-20% 100VDCW	72982	801-K800011	
A1C4	0150-0093		C:FXD CER 0.01 UF +80-20% 100VDCW	72982	801-K800011	
A1C5	0150-0093		C:FXD CER 0.01 UF +80-20% 100VDCW	72982	801-K800011	
A1C6	0150-0093		C:FXD CER 0.01 UF +80-20% 100VDCW	72982	801-K800011	
A1C7	0150-0093		C:FXD CER 0.01 UF +80-20% 100VDCW	72982	801-K800011	
A1C8	0150-0093	3	C:FXD CER 0.01 UF +80-20% 100VDCW	72982	801-K800011	
A1C9	0180-1701		C:FXD ELECT 6.8 UF 20% 6VDCW	28480	0180-1701	
A1C12*	0140-0199  		C:FXD MICA 240 PF 300VDCW	72136	DM15F241J0300WV1CR	
A1C13*	0140-0208  	1	C:FXD MICA 680 PF 300VDCW	72136	DM15F681J0300WV1CR	
A1C101, C102	0180-0582		C:FXD 270UF 30VDCW	56289	6720277H0400T27	
A1C103, C104	0180-0581		C:FXD AL 120 UF 50VDCW	56289	6720127H0500T2C	
A1C105, C106	0180-0582		C:FXD 270 UF 30VDCW	56289	6720277H0400T27	
A1C107	0180-0581		C:FXD AL 120 UF 50VDCW	56289	6720127H0500T2C	
A1C108	1200-0185	7	INSULATOR: PLASTIC (FOR C101-C107)	13103	7717-88N Rad	
A1C109	0180-0309	2	C:FXD ELECT 4.7 UF 20% 10VDCW	56289	1500475X0010A2-DYS	
A1C109	0150-0071	12	C:FXD CER 400 PF +80-20% 500VDCW	56289	C016B102E401J527-CDH	
A1C110	0180-0197	13	C:FXD ELECT 2.2 UF 10% 20VDCW	56289	1500225X9020A2-DYS	
A1C111	0180-1746	7	C:FXD ELECT 15 UF 10% 20VDCW	28480	0180-1746	
A1C112	0150-0096	3	C:FXD CER 0.05 UF +80-20% 100VDCW	91418	TA	
A1C113	0180-0291	4	C:FXD ELECT 1.0 UF 10% 35VDCW	56289	1500105X9035A2-DYS	
A1C114	0150-0050		C:FXD CER 1000 PF +80-20% 1000VDCW	56289	C067B102E102Z526-CDH	
A1C115	0180-1746		C:FXD ELECT 15 UF 10% 20VDCW	28480	0180-1746	
A1C116	0180-0309	1	C:FXD ELECT 4.7 UF 20% 10VDCW	56289	1500475X0010A2-DYS	
A1C117	0150-0096		C:FXD CER 0.05 UF +80-20% 100VDCW	91418	TA	
A1C118	0180-0291		C:FXD ELECT 1.0 UF 10% 35VDCW	56289	1500105X9035A2-DYS	
A1C119	0180-2507		C:FXD 6000 UF	28480	0180-2507	
A1C121	0150-0096		C:FXD CER 0.05 UF +80-20% 100VDCW	91418	TA	
A1C122	0180-1704		1	C:FXD ELECT 47 UF 10% 6VDCW	28480	0180-1704
A1C201	0160-0356		1	C:FXD MICA 18 PF 5%	28480	0160-0356
A1C202	0140-0194	1	C:FXD MICA 110 PF 5%	72136	RDMI5F111J3C	
A1C203	5080-9047	1	C:FXD 0.33 UF 10% (HAND SELECTED)	28480	5080-9047	
A1C204	0160-0181	2	C:FXD MICA 30PF 5% 300VDCW	14655	RDMI5E300J35	
A1C205	0160-2605	4	C:FXD CER 0.02 MFD +80-20% 25VDCW	72982	5835000-Y5U 203Z	
A1C206	0150-0093		C:FXD CER 0.01 UF +80-20% 100VDCW	72982	801-K800011	
A1C207	0160-3133		C:FXD MY 2 UF 10% 100VDCW	84411	663UM	
A1C208	0160-2605		C:FXD CER 0.02 MFD +80-20% 25VDCW	72982	5835000-Y5U 203Z	
A1C209	0140-0201	1	C:FXD MICA 12 PF 5%	28480	0140-0201	
A1C210	0150-0059	1	C:FXD CER 3.3-0.25 PF 500VDCW	72982	301-000-C0J0-339C	
A1C302	0180-0374	1	C:FXD 10 UF 20 VDC	56289	150D106X9020B2	
A1C304	0160-2605	2	C:FXD CER 0.02 MFD +80-20% 25VDCW	72982	5835000-Y5U 203Z	
A1C305	0160-0620		C:FXD CER 0.05 UF +80-20% 25VDCW	72982	5855 Y5U 503Z	
A1C306	0150-0024  		C:FXD .02 UF 600 VDCW CER	71590	DD203-Z5U- +80- 20	
A1C307	0150-0096 		C:FXD .05 UF 100 VDCW CER	28480	0150-0096	
A1C401	0160-2199	4	C:FXD MICA 30 PF 5% 300VDCW	28480	0160-2199	
A1C403	0150-0084 	5	C:FXD CER 0.1 UF +80-20% 100VDCW	72982	8131-100-651-104Z	
A1C501	0170-0019  	1	C:FXD MY 0.1 UF 5% 200VDCW	28480	0170-0019	
A1C502	0150-0084  	1	C:FXD CER 0.1 UF +80-20% 100VDCW	72982	8131-100-651-104Z	
A1C503	0160-2207 		C:FXD MICA 300 PF 5%	28480	0160-2207	
A1C504	0150-0084 		C:FXD CER 0.1 UF +80-20% 100VDCW	72982	8131-100-651-104Z	
A1C505	0170-0021 	3	C:FXD MY 4700PF 10% 400VDCW	84411	663UM47294	
A1C506	0180-0291  		C:FXD ELECT 1.0 UF 10% 35VDCW	56289	1500105X9035A2-DYS	
A1C507	0180-0291 		C:FXD ELECT 1.0 UF 10% 35VDCW	56289	1500105X9035A2-DYS	
A1C508	0170-0021 		C:FXD MY 4700PF 10% 400VDCW	84411	663UM47294	
A1CR1	1901-0040	52	DIODE:SILICON 50 MA 30 WV	07263	FDG1088	
A1CR2	1907-0041	4	DIODE:BREAKDOWN 5-11V 5%	04713	SZ10939-98	
A1CR3	1907-0049	3	DIODE:BREAKDOWN 6-19V 5%	04713	SZ10939-122	

△ Refer to Backdating Sec. VIII

See introduction to this section for ordering information













Table 6-1. Replaceable Parts(Cont'd)

Reference Designation	HP Part Number	Qty	Description	Mfr Code	Mfr Part Number
A1CR4	1907-0041		DIODE:BRFAKDOWN 5.11V 5%	04713	SZ10939-98
A1CR5	1901-0040		DIODE:SILICON 50 MA 30 WV	07263	FDG1088
A1CR6	1901-0040		DIODE:SILICON 50 MA 30 WV	07263	FDG1088
A1CR7	1901-0040		DIODE:SILICON 50 MA 30 WV	07263	FDG1088
A1CR8	1901-0518 		DIODE:HOT CARRIER	28480	1901-0518
A1CR101	1901-0028	10	DIODE:SILICON 0.75A 400PIV	04713	SR1358-9
A1CR102	1901-0028		DIODE:SILICON 0.75A 400PIV	04713	SR1358-9
A1CR103	1901-0028		DIODE:SILICON 0.75A 400PIV	04713	SR1358-9
A1CR104	1901-0028		DIODE:SILICON 0.75A 400PIV	04713	SR1358-9
A1CR105	1901-0028		DIODE:SILICON 0.75A 400PIV	04713	SR1358-9
A1CR106	1901-0028		DIODE:SILICON 0.75A 400PIV	04713	SR1358-9
A1CR107	1901-0028		DIODE:SILICON 0.75A 400PIV	04713	SR1358-9
A1CR108	1901-0028		DIODE:SILICON 0.75A 400PIV	04713	SR1358-9
A1CR109	1901-0040		DIODE:SILICON 50 MA 30 WV	07263	FDG1088
A1CR110	1902-0184	1	DIODE BRFAKDOWN: SILICON 16.2V 5%	28480	1902-0184
A1CR111	1902-0594	2	DIODE BRFAKDOWN: 18.2V 5% 1W	04713	SZ11213-215
A1CR112	1901-0040		DIODE: SILICON 50 MA 30 WV	07263	FDG1088
A1CR113	1902-0654	2	DIODE BRFAKDOWN: 3.2V 5%	28480	1902-0654
A1CR114	1902-0594		DIODE BRFAKDOWN: 18.2V 5% 1W	04713	SZ11213-215
A1CR115	1902-0514	1	DIODE:ZFNER 5.62V 2% 1W	28480	1902-0514
A1CR116	1902-0559	1	DIODE BRFAKDOWN: 6.19V +2%	04713	SZ11213-81
A1CR117	1901-0040		DIODE: SILICON 50 MA 30 WV	07263	FDG1088
A1CR118	1902-0654		DIODE BRFAKDOWN: 3.2V 5%	28480	1902-0654
A1CR119	1901-0200	2	DIODE:SI 3 A 100 PRRV	28480	1901-0200
A1CR120	1901-0200		DIODE:SI 3 A 100 PRRV	28480	1901-0200
A1CR121	1901-0040		DIODE: SILICON 50 MA 30 WV	07263	FDG1088
A1CR122	1901-0040 		DIODE: SILICON 50 MA 30 WV	07263	FDG1088
A1CR123	1901-0040 		DIODE: SILICON 50 MA 30 WV	07263	FDG1088
A1CR201	1901-0040		DIODE: SILICON 50 MA 30 WV	07263	FDG1088
A1CR202	1901-0040		DIODE: SILICON 50 MA 30 WV	07263	FDG1088
A1CR203	1901-0040		DIODE: SILICON 50 MA 30 WV	07263	FDG1088
A1CR204	1902-3104	2	DIODE:BRFAKDOWN 5.62V 5%	04713	SZ10939-110
A1CR205	1901-0040		DIODE: SILICON 50 MA 30 WV	07263	FDG1088
A1CR206	1901-0040		DIODE: SILICON 50 MA 30 WV	07263	FDG1088
A1CR401	1901-0040		DIODE: SILICON 50 MA 30 WV	07263	FDG1088
A1CR402	1901-0040		DIODE: SILICON 50 MA 30 WV	07263	FDG1088
A1CR403	1902-0025	1	DIODE BRFAKDOWN: 10.0V 5% 400 MW	28480	1902-0025
A1CR501	1902-3190	8	DIODE BRFAKDOWN: 13.0V 5% 400 MW	28480	1902-3190
A1CR502	1901-0040		DIODE: SILICON 50 MA 30 WV	07263	FDG1088
A1CR503	1901-0040		DIODE: SILICON 50 MA 30 WV	07263	FDG1088
A1CR504	1902-3190		DIODE BRFAKDOWN: 13.0V 5% 400 MW	28480	1902-3190
A1CR505	1901-0040		DIODE: SILICON 50 MA 30 WV	07263	FDG1088
A1CR506	1901-0040		DIODE: SILICON 50 MA 30 WV	07263	FDG1088
A1CR507	1901-0040		DIODE: SILICON 50 MA 30 WV	07263	FDG1088
A1CR508	1901-0040		DIODE: SILICON 50 MA 30 WV	07263	FDG1088
A1CR509	1901-0040		DIODE: SILICON 50 MA 30 WV	07263	FDG1088
A1CR510	1901-0040		DIODE: SILICON 50 MA 30 WV	07263	FDG1088
A1CR511	1901-0040		DIODE: SILICON 50 MA 30 WV	07263	FDG1088
A1CR512	1901-0040		DIODE: SILICON 50 MA 30 WV	07263	FDG1088
A1CR513	1902-0049		DIODE:BRFAKDOWN 6.19V 5%	04713	SZ10939-122
A1J1	1251-2134	4	CONNECTOR:PC (2X18)36 CONTACTS	71785	252-18-30-340
A1J2	1251-2292	2	CONNECTOR:PC (1 X 18) 18 CONTACT	71785	252-18-30-350
A1J3	1251-2292		CONNECTOR:PC (1 X 18) 18 CONTACT	71785	252-18-30-350
A1J5	1251-2134		CONNECTOR:PC (2X18)36 CONTACTS	71785	252-18-30-340
A1J6	1251-2034	1	CONNECTOR:PC EDGE (2 X 10) 20 CONTACT	71785	252-10-30-300
A1J7	1251-2134		CONNECTOR:PC (2X18)36 CONTACTS	71785	252-18-30-340
A1J8	1251-2134		CONNECTOR:PC (2X18)36 CONTACTS	71785	252-18-30-340
A1K401	0490-0740	1	RELAY:RFFD	28480	0490-0740
A1K402	0490-1105	3	SWITCH:REED	28480	0490-1105
A1MP1	1200-0469	5	SOCKET:IC 28 CONTACT DUAL-INLINE TYPE	28480	1200-0469
A1MP2	1200-0469		SOCKET:IC 28 CONTACT DUAL-INLINE TYPE	28480	1200-0469
A1MP3	1200-0431	5	SOCKET:IC 24 CONTACT	28480	1200-0431

△ Refer to Backdating Sec. VIII

See introduction to this section for ordering information





Table 6-1. Replaceable Parts(Cont'd)

Reference Designation	HP Part Number	Qty	Description	Mfr Code	Mfr Part Number
A1MP4	1200-0473	20	SOCKET: IC 16-PIN	28480	1200-0473
A1MP5	1200-0474	33	SOCKET: IC 14-PIN	28480	1200-0474
A1MP6	0340-0060	20	FEEDTHRU: INSULATED MOUNTING	28480	0340-0060
A1MP7	0340-0060		FEEDTHRU: INSULATED MOUNTING	28480	0340-0060
A1MP8	1200-0437	14	SOCKET: IC 8 PIN	17117	5566-235-5
A1MP9	1200-0437		SOCKET: IC 8 PIN	17117	5566-235-5
A1MP1C	1205-0033	2	HEAT SINK: SEMICONDUCTOR	05820	207-CR
A1MP11	1205-0033		HEAT SINK: SEMICONDUCTOR	05820	207-CR
A1MP12	1400-0760	21	CLIP: MOUNTING ASSY (SET OF 3)	28480	1400-0760
A1MP13	1400-0760		CLIP: MOUNTING ASSY (SET OF 3)	28480	1400-0760
A1P1	1251-3234	1	CONNECTOR STRIP: 14-PIN	28480	1251-3234
A1P2	1251-3236	1	CONNECTOR STRIP: 18-PIN	28480	1251-3236
A101	1853-0010	19	TSTR: SI PNP (SELECTED FROM 2N3251)	28480	1853-0010
A107	1854-0071	47	TSTR: SI NPN (SELECTED FROM 2N3704)	28480	1854-0071
A103	1854-0071		TSTR: SI NPN (SELECTED FROM 2N3704)	28480	1854-0071
A10101	1854-0569	2	TSTR: SI NPN	28480	1854-0569
A10102	1854-0087	17	TSTR: SI NPN	80131	2N3417
A10103	1854-0087		TSTR: SI NPN	80131	2N3417
A10104	1853-0051	1	TSTR: SI PNP	80131	2N4037
A10105	1853-0086	5	TSTR: SI PNP	80131	2N5087
A10106	1854-0071		TSTR: SI NPN (SELECTED FROM 2N3704)	28480	1854-0071
A10107	1854-0569		TSTR: SI NPN	28480	1854-0569
A10108	1853-0086		TSTR: SI PNP	80131	2N5087
A10109	1853-0086		TSTR: SI PNP	80131	2N5087
A10110	1854-0039	2	TSTR: SI NPN	80131	2N3053
A10111	1854-0039		TSTR: SI NPN	80131	2N3053
A10112	1854-0071		TSTR: SI NPN (SELECTED FROM 2N3704)	28480	1854-0071
A10201	1853-0010		TSTR: SI PNP (SELECTED FROM 2N3251)	28480	1853-0010
A10202	1854-0215	9	TSTR: SI NPN	80131	2N3904
A10203	1854-0215		TSTR: SI NPN	80131	2N3904
A10204	1855-0093	9	TSTR: FFT N-CHANNEL	28480	1855-0093
A10205	1855-0093		TSTR: FFT N-CHANNEL	28480	1855-0093
A10206	1855-0308	5	TSTR: SI NPN DUAL	28480	1855-0308
A10207	1855-0308		TSTR: SI NPN DUAL	28480	1855-0308
A10208	1855-0093		TSTR: FFT N-CHANNEL	28480	1855-0093
A10209	1855-0410	1	TSTR: FFT	28480	1855-0410
A10210	1853-0010		TSTR: SI PNP (SELECTED FROM 2N3251)	28480	1853-0010
A10211	1854-0215		TSTR: SI NPN	80131	2N3904
A10401	1853-0036 	4	TSTR: SI PNP	80131	2N3906
A10402	1853-0010		TSTR: SI PNP (SELECTED FROM 2N3251)	28480	1853-0010
A10403	1854-0215 		TSTR: SI NPN	04713	SPS 3611
A10404	1853-0010		TSTR: SI PNP (SELECTED FROM 2N3251)	28480	1853-0010
A10405	1854-0215 		TSTR: SI NPN	04713	SPS 3611
A10406	1853-0010		TSTR: SI PNP (SELECTED FROM 2N3251)	28480	1853-0010
A10407	1854-0215 		TSTR: SI NPN	04713	SPS 3611
A10408	1853-0036 		TSTR: SI PNP	80131	2N3906
A10409	1853-0010		TSTR: SI PNP (SELECTED FROM 2N3251)	28480	1853-0010
A1041C	1854-0215 		TSTR: SI NPN	04713	SPS 3611
A10411	1853-0010		TSTR: SI PNP (SELECTED FROM 2N3251)	28480	1853-0010
A10412	1854-0215 		TSTR: SI NPN	04713	SPS 3611
A10413	1853-0010		TSTR: SI PNP (SELECTED FROM 2N3251)	28480	1853-0010
A10414	1854-0215 		TSTR: SI NPN	04713	SPS 3611
A10415	1853-0010		TSTR: SI PNP (SELECTED FROM 2N3251)	28480	1853-0010
A10416	1854-0215 		TSTR: SI NPN	04713	SPS 3611
A10417	1853-0010		TSTR: SI PNP (SELECTED FROM 2N3251)	28480	1853-0010
A10418	1854-0215 		TSTR: SI NPN	04713	SPS 3611
A10420	1853-0010		TSTR: SI PNP (SELECTED FROM 2N3251)	28480	1853-0010
A10421	1854-0215 		TSTR: SI NPN	04713	SPS 3611
A10422	1853-0010		TSTR: SI PNP (SELECTED FROM 2N3251)	28480	1853-0010
A10423	1854-0215 		TSTR: SI NPN	04713	SPS 3611
A10424	1853-0010		TSTR: SI PNP (SELECTED FROM 2N3251)	28480	1853-0010

△ Refer to Backdating Sec. VIII

See introduction to this section for ordering information

Table 6-1. Replaceable Parts(Cont'd)

Reference Designation	HP Part Number	Qty	Description	Mfr Code	Mfr Part Number
A10425 A10426 A10427	1854-0215  1853-0010  1854-0215 		TSTR:SI NPN TSTR:SI PNP(SELCTED FROM 2N3251) TSTR:SI NPN	04713 28480 04713	SPS 3611 1853-0010 SPS 3611
A10501 A10502 A10503 A10504 A10505	1853-0036 1853-0036 1854-0215 1854-0215 1854-0215		TSTR:SI PNP TSTR:SI PNP TSTR:SI NPN TSTR:SI NPN TSTR:SI NPN	80131 80131 80131 80131 80131	2N3906 2N3906 2N3904 2N3904 2N3904
A10506 A1C507 A10508 A10505 A1051C	1853-0235 1853-0235 1854-0215 1854-0221 1854-0215	3 1	TSTR:SI PNP TSTR:SI PNP TSTR:SI NPN TSTR:SI NPN(REPL. BY 2N4044) TSTR:SI NPN	28480 28480 80131 28480 80131	1853-0235 1853-0235 2N3904 1854-0221 2N3904
A10511 A10512 A10CR301	1853-0235 1854-0071 5060-6000	1	TSTR:SI PNP TSTR:SI NPN(SFICTED FROM 2N3704) REFERENCE AMP ASSY: INCLUDES R306, 308, 310, 313, 314, 315	28480 28480	1853-0235 1854-0371
A1R1	0684-1531	39	R:FXD COMP 15K OHM 10% 1/4W	28480 01121	5060-6000 CB 1531
A1R2 A1R3 A1R4 A1R5 A1R6	0684-1821  0684-1531 0684-1531 0684-1531 0684-1531		R:FXD COMP 1.8K OHM 10% 1/4W R:FXD COMP 15K OHM 10% 1/4W R:FXD COMP 15K OHM 10% 1/4W R:FXD COMP 15K OHM 10% 1/4W R:FXD COMP 15K OHM 10% 1/4W	01121 01121 01121 01121 01121	CB 1821 CB 1531 CB 1531 CB 1531 CB 1531
A1R7 A1R8 A1R9 A1R10 A1R11	0684-2231 0684-2231 0684-2231 0684-2231 0684-1231	9 6	R:FXD COMP 22K OHM 10% 1/4W R:FXD COMP 22K OHM 10% 1/4W R:FXD COMP 22K OHM 10% 1/4W R:FXD COMP 22K OHM 10% 1/4W R:FXD COMP 12K OHM 10% 1/4W	01121 01121 01121 01121 01121	CB 2231 CB 2231 CB 2231 CB 2231 CB 1231
A1R12 A1R13 A1R14 A1R15 A1R16	0684-3321 0684-3331 0684-3331 0684-6821 0684-3331	11 7 71	R:FXD COMP 3300 OHM 10% 1/4W R:FXD COMP 33K OHM 10% 1/4W R:FXD COMP 33K OHM 10% 1/4W R:FXD COMP 6.8K OHM 10% 1/4W R:FXD COMP 33K OHM 10% 1/4W	01121 01121 01121 01121 01121	CB 3321 CB 3331 CB 3331 CB 6821 CB 3331
A1R17 A1R18 A1R19 A1R20 A1R21	0684-1021 0684-1531 0684-1531 0684-1531 0684-1531	15	R:FXD COMP 1000 OHM 10% 1/4W R:FXD COMP 15K OHM 10% 1/4W R:FXD COMP 15K OHM 10% 1/4W R:FXD COMP 15K OHM 10% 1/4W R:FXD COMP 15K OHM 10% 1/4W	01121 01121 01121 01121 01121	CB 1021 CB 1531 CB 1531 CB 1531 CB 1531
A1R22 A1R23 A1R24 A1R25 A1R26	0684-1531 0684-1531 0684-1531 0684-1531 0684-1531		R:FXD COMP 15K OHM 10% 1/4W R:FXD COMP 15K OHM 10% 1/4W R:FXD COMP 15K OHM 10% 1/4W R:FXD COMP 15K OHM 10% 1/4W R:FXD COMP 15K OHM 10% 1/4W	01121 01121 01121 01121 01121	CB 1531 CB 1531 CB 1531 CB 1531 CB 1531
A1R27 A1R28 A1R29 A1R30 A1R31	0684-1531 0684-1531 0684-1531 0684-1531 0684-1531		R:FXD COMP 15K OHM 10% 1/4W R:FXD COMP 15K OHM 10% 1/4W R:FXD COMP 15K OHM 10% 1/4W R:FXD COMP 15K OHM 10% 1/4W R:FXD COMP 15K OHM 10% 1/4W	01121 01121 01121 01121 01121	CB 1531 CB 1531 CB 1531 CB 1531 CB 1531
A1R32 A1R33 A1R34 A1R35 A1R36	0684-1531 0757-0469 0757-0465 0684-6821 0684-6821	1 11	R:FXD COMP 15K OHM 10% 1/4W R:FXD FLM 150K OHM 1% 1/8W R:FXD MET FLM 100K OHM 1% 1/8W R:FXD COMP 6.8K OHM 10% 1/4W R:FXD COMP 6.8K OHM 10% 1/4W	01121 28480 28480 01121 01121	CB 1531 0757-0469 0757-0465 CB 6821 CB 6821
A1R37 A1R38 A1R39 A1R40 A1R41	0684-6821 0684-6821 0684-6821 0684-6821 0684-6821		R:FXD COMP 6.8K OHM 10% 1/4W R:FXD COMP 6.8K OHM 10% 1/4W R:FXD COMP 6.8K OHM 10% 1/4W R:FXD COMP 6.8K OHM 10% 1/4W R:FXD COMP 6.8K OHM 10% 1/4W	01121 01121 01121 01121 01121	CB 6821 CB 6821 CB 6821 CB 6821 CB 6821
A1R42 A1R43 A1R44 A1R45 A1R46	0684-6821 0684-6821 0684-6821 0684-6821 0684-6821		R:FXD COMP 6.8K OHM 10% 1/4W R:FXD COMP 6.8K OHM 10% 1/4W R:FXD COMP 6.8K OHM 10% 1/4W R:FXD COMP 6.8K OHM 10% 1/4W R:FXD COMP 6.8K OHM 10% 1/4W	01121 01121 01121 01121 01121	CB 6821 CB 6821 CB 6821 CB 6821 CB 6821
A1R47 A1R48 A1R49 A1R50 A1R51 A1R52	0684-6821 0684-6821 0684-6821 0684-6821 0684-6821 0684-3331 		R:FXD COMP 6.8K OHM 10% 1/4W R:FXD COMP 6.8K OHM 10% 1/4W R:FXD COMP 6.8K OHM 10% 1/4W R:FXD COMP 6.8K OHM 10% 1/4W R:FXD COMP 6.8K OHM 10% 1/4W R:FXD COMP 33K OHM 10% 1/4W	01121 01121 01121 01121 01121 01121	CB 6821 CB 6821 CB 6821 CB 6821 CB 6821 CB 3331
A1R101 A1R102 A1R103	0757-0438 0757-0438 0757-0392	6 1	R:FXD MET FLM 5.11K OHM 1% 1/8W R:FXD MET FLM 5.11K OHM 1% 1/8W R:FXD MET FLM 43.2 OHM 1% 1/8W	28480 28480 28480	0757-0438 0757-0438 0757-0392

See introduction to this section for ordering information

Table 6-1. Replaceable Parts(Cont'd)

Reference Designation	HP Part Number	Qty	Description	Mfr Code	Mfr Part Number
A1R104	0683-0335	2	R:FXD COMP 3.3 OHM 5% 1/4W	01121	CB 0335
A1R105	0698-3264	2	R:FXD FLM 11.8K OHM 1% 1/8W	28480	0698-3264
A1R107	0698-4474	2	R:FXD FLM 8450 OHM 1% 1/8W	28480	0698-4474
A1R108	0684-2721	4	R:FXD COMP 2700 OHM 10% 1/4W	01121	CB 2721
A1R109	0757-0429	2	R:FXD MET FLM 1.82K OHM 1% 1/8W	28480	0757-0429
A1R11C	0757-0441	4	R:FXD MET FLM 8.25K OHM 1% 1/8W	28480	0757-0441
A1R111	0757-0709	1	R:FXD MET FLM 68.1 OHM 1% 1/4W	28480	0757-0709
A1R112	0698-3259	2	R:FXD FLM 7.87K OHM 1% 1/8W	28480	0698-3259
A1R113	0757-0442	12	R:FXD MET FLM 10.0K OHM 1% 1/8W	28480	0757-0442
A1R114	0757-0442		R:FXD MET FLM 10.0K OHM 1% 1/8W	28480	0757-0442
A1R115	0757-0442		R:FXD MET FLM 10.0K OHM 1% 1/8W	28480	0757-0442
A1R116	0684-2721	15	R:FXD COMP 2700 OHM 10% 1/4W	01121	CB 2721
A1R117	0684-3911	1	R:FXD COMP 390 OHM 10% 1/4W	01121	CB 3911
A1R118	0683-0335		R:FXD COMP 3.3 OHM 5% 1/4W	01121	CB 0335
A1R119	0684-4711	2	R:FXD COMP 470 OHM 10% 1/4W	01121	CB 4711
A1R12C	0684-4731	5	R:FXD COMP 47K OHM 10% 1/4W	01121	CB 4731
A1R121	0684-2721		R:FXD COMP 2700 OHM 10% 1/4W	01121	CB 2721
A1R122	0684-2721		R:FXD COMP 2700 OHM 10% 1/4W	01121	CB 2721
A1R123	0757-0429		R:FXD MET FLM 1.82K OHM 1% 1/8W	28480	0757-0429
A1R124	0757-0441		R:FXD MET FLM 8.25K OHM 1% 1/8W	28480	0757-0441
A1R125	0757-0711	1	R:FXD MET FLM 82.5 OHM 1% 1/4W	28480	0757-0711
A1R126	0698-3259		R:FXD FLM 7.87K OHM 1% 1/8W	28480	0698-3259
A1R127	0757-0442		R:FXD MET FLM 10.0K OHM 1% 1/8W	28480	0757-0442
A1R128	0684-2721		R:FXD COMP 2700 OHM 10% 1/4W	01121	CB 2721
A1R129	0684-1811	4	R:FXD COMP 180 OHM 10% 1/4W	01121	CB 1811
A1R13C	0698-4471	1	R:FXD FLM 7.15K OHM 1% 1/8W	28480	0698-4471
A1R131	0757-0273	3	R:FXD MET FLM 3.01K OHM 1% 1/8W	28480	0757-0273
A1R201	0684-1531		R:FXD COMP 15K OHM 10% 1/4W	01121	CB 1531
A1R202	0684-4721	25	R:FXD COMP 4700 OHM 10% 1/4W	01121	CB 4721
A1R203	0684-1021		R:FXD COMP 1000 OHM 10% 1/4W	01121	CB 1021
A1R204	0684-3331		R:FXD COMP 33K OHM 10% 1/4W	01121	CB 3331
A1R205	0684-1021		R:FXD COMP 1000 OHM 10% 1/4W	01121	CB 1021
A1R206	0698-3155	1	R:FXD MET FLM 3.64K OHM 1% 1/8W	28480	0698-3155
A1R207 (OP D6D)	0698-4510	3	R:FXD MET FLM 84.5K OHM 1% 1/8W	28480	0698-4510
A1R207 (OP D5D)	0757-0465		R:FXD MET FLM 100K OHM 1% 1/8W	28480	0757-0465
A1R208	0757-0448	2	R:FXD MET FLM 18.2K OHM 1% 1/8W	28480	0757-0448
A1R209	0757-0448		R:FXD MET FLM 18.2K OHM 1% 1/8W	28480	0757-0448
A1R211	0757-0442		R:FXD MET FLM 10.0K OHM 1% 1/8W	28480	0757-0442
A1R212	0757-0442		R:FXD MET FLM 10.0K OHM 1% 1/8W	28480	0757-0442
A1R213	0698-3279	2	R:FXD MET FLM 4990 OHM 1% 1/8W	28480	0698-3279
A1R214	0698-4510		R:FXD MET FLM 84.5K OHM 1% 1/8W	28480	0698-4510
A1R215	0698-4510		R:FXD MET FLM 84.5K OHM 1% 1/8W	28480	0698-4510
A1R216	0757-0465		R:FXD MET FLM 100K OHM 1% 1/8W	28480	0757-0465
A1R217	0757-0401	5	R:FXD MET FLM 100 OHM 1% 1/8W	28480	0757-0401
A1R218	0698-3700	1	R:FXD FLM 715 OHM 1% 1/8W	28480	0698-3700
A1R219	0698-0077	1	R:FXD MET FLM 93.1K OHM 1% 1/8W	28480	0698-0077
A1R22C	0684-4721		R:FXD COMP 4700 OHM 10% 1/4W	01121	CB 4721
A1R221	0684-1531		R:FXD COMP 15K OHM 10% 1/4W	01121	CB 1531
A1R222	0684-4721		R:FXD COMP 4700 OHM 10% 1/4W	01121	CB 4721
A1R223	0684-1231		R:FXD COMP 12K OHM 10% 1/4W	01121	CB 1231
A1R224	0698-4474		R:FXD FLM 8450 OHM 1% 1/8W	28480	0698-4474
A1R22E	0757-0401		R:FXD MET FLM 100 OHM 1% 1/8W	28480	0757-0401
A1R227	0684-1541	13	R:FXD COMP 150K OHM 10% 1/4W	01121	CB 1541
A1R306 *			SEE A1QCR301		
A1R308 *			SEE A1QCR301		
A1R310 *			SEE A1QCR301		
A1R312 *	0698-4509	1	R:FXD FLM 80.6K OHM 1% 1/8W	28480	0698-4509
A1R313 *			SEE A1QCR301		
A1R314 *			SEE A1QCR301		
A1R315 *			SEE A1QCR301		
A1R31E	0811-3173	1	R:MATCHED SET WITH A1R318	28480	0811-3173
A1R31F	0811-3173		R:MATCHED SET WITH A1R31E	28480	0811-3173
A1R31S	0698-3279		R:FXD MET FLM 4990 OHM 1% 1/8W	28480	0698-3279
A1R32C	0757-0391	1	R:FXD FLM 39.2 OHM 1% 1/8W	28480	0757-0391
A1R321	0757-0346	3	R:FXD MET FLM 13 OHM 1% 1/8W	28480	0757-0346

△ Refer to Backdating Sec. VIII

See introduction to this section for ordering information

Table 6-1. Replaceable Parts(Cont'd)

Reference Designation	HP Part Number	Qty	Description	Mfr Code	Mfr Part Number
A1R322 A1R323 A1R324 A1R325	0757-0472 0698-8182 0757-0391 0757-0346		R: 200K 1% .125W R: 2.21K 1% .125W R: 39.2 OHM 1% .125W R:FXD 10 OHM 01	24546 19701 24546 28480	C4-1/8-TO-2003-F MF4C1/8-T9-2211-F C4-1/8-TO 39R2 F 0757-0346
A1R401 A1R402 A1R403	0684-4721 0684-4721 0684-1531		R:FXD COMP 4700 OHM 10% 1/4W R:FXD COMP 4700 OHM 10% 1/4W R:FXD COMP 15K OHM 10% 1/4W	01121 01121 01121	CR 4721 CR 4721 CR 1531
A1R404 A1R405 A1R406 A1R407 A1R408	0684-4721 0684-1541 0684-1541 0684-4721 0684-1541		R:FXD COMP 4700 OHM 10% 1/4W R:FXD COMP 150K OHM 10% 1/4W R:FXD COMP 15K OHM 10% 1/4W R:FXD COMP 4700 OHM 10% 1/4W R:FXD COMP 150K OHM 10% 1/4W	01121 01121 01121 01121 01121	CR 4721 CR 1541 CR 1531 CR 4721 CR 1541
A1R409 A1R410 A1R411 A1R412 A1R413	0684-1541 0684-4721 0684-1541 0684-4721 0684-4721		R:FXD COMP 15K OHM 10% 1/4W R:FXD COMP 4700 OHM 10% 1/4W R:FXD COMP 150K OHM 10% 1/4W R:FXD COMP 4700 OHM 10% 1/4W R:FXD COMP 4700 OHM 10% 1/4W	01121 01121 01121 01121 01121	CR 1531 CR 4721 CR 1541 CR 4721 CR 4721
A1R414 A1R415 A1R416 A1R417 A1R418	0684-1541 0684-4721 0684-1541 0684-1531 0684-4721		R:FXD COMP 15K OHM 10% 1/4W R:FXD COMP 4700 OHM 10% 1/4W R:FXD COMP 150K OHM 10% 1/4W R:FXD COMP 15K OHM 10% 1/4W R:FXD COMP 4700 OHM 10% 1/4W	01121 01121 01121 01121 01121	CR 1531 CR 4721 CR 1541 CR 1531 CR 4721
A1R419 A1R420 A1R421 A1R422 A1R423	0684-1541 0684-1531 0684-4721 0684-1541 0684-1531		R:FXD COMP 150K OHM 10% 1/4W R:FXD COMP 15K OHM 10% 1/4W R:FXD COMP 4700 OHM 10% 1/4W R:FXD COMP 150K OHM 10% 1/4W R:FXD COMP 15K OHM 10% 1/4W	01121 01121 01121 01121 01121	CR 1541 CR 1531 CR 4721 CR 1541 CR 1531
A1R424 A1R425 A1R426 A1R427 A1R428	0684-4721 0684-1541 0684-1531 0684-4721 0684-1541		R:FXD COMP 4700 OHM 10% 1/4W R:FXD COMP 150K OHM 10% 1/4W R:FXD COMP 15K OHM 10% 1/4W R:FXD COMP 4700 OHM 10% 1/4W R:FXD COMP 150K OHM 10% 1/4W	01121 01121 01121 01121 01121	CR 4721 CR 1541 CR 1531 CR 4721 CR 1541
A1R429 A1R430 A1R431 A1R432 A1R433	2100-3257 0684-1531 0684-1531 0684-4721 0684-5021	3 1 1 1 5	R:VAR 20K OHM 10% R:FXD COMP 39K OHM 10% 1/4W R:FXD COMP 15K OHM 10% 1/4W R:FXD COMP 4700 OHM 10% 1/4W R:FXD COMP 5.1K OHM 10% 1/4W	28480 01121 01121 01121 01121	2100-3257 CR 1531 CR 1531 CR 4721 CR 5671
A1R434 A1R435 A1R436 A1R437 A1R438	0684-1541 0684-1531 0684-4721 0684-1541 0684-1531		R:FXD COMP 150K OHM 10% 1/4W R:FXD COMP 15K OHM 10% 1/4W R:FXD COMP 4700 OHM 10% 1/4W R:FXD COMP 150K OHM 10% 1/4W R:FXD COMP 15K OHM 10% 1/4W	01121 01121 01121 01121 01121	CR 1541 CR 1531 CR 4721 CR 1541 CR 1531
A1R439 A1R440 A1R441 A1R442 A1R443	0684-4721 0684-1541 0684-1531 0684-4721 0684-1541		R:FXD COMP 4700 OHM 10% 1/4W R:FXD COMP 150K OHM 10% 1/4W R:FXD COMP 15K OHM 10% 1/4W R:FXD COMP 4700 OHM 10% 1/4W R:FXD COMP 150K OHM 10% 1/4W	01121 01121 01121 01121 01121	CR 4721 CR 1541 CR 1531 CR 4721 CR 1541
A1R444 A1R445 A1R446	0757-0472 0757-0465 0684-1531	2	R:FXD MET FILM 200K OHM 1% 1/8W R:FXD MET FILM 100K OHM 1% 1/8W R:FXD COMP 15K OHM 10% 1/4W	28480 28480 01121	0757-0472 0757-0465 CR 1531
A1R501 A1R502 A1R503 A1R504 A1R505	0698-4494 0757-0441 0757-0274 0757-0457 0757-0453	2 2 2 10	R:FXD FILM 35.7K OHM 1% 1/8W R:FXD MET FILM 8.25K OHM 1% 1/8W R:FXD MET FILM 3.01K OHM 1% 1/8W R:FXD MET FILM 47.5K OHM 1% 1/8W R:FXD MET FILM 33.1K OHM 1% 1/8W	28480 28480 28480 28480 28480	0698-4494 0757-0441 0757-0273 0757-0457 0757-0453
A1R506 A1R507 A1R508 A1R509 A1R510 A1R511A	0757-0453 0757-0453 0698-4496 0698-4496 0698-4426	2 2 2 1	R:FXD MET FILM 33.1K OHM 1% 1/8W R:FXD MET FILM 33.1K OHM 1% 1/8W R:FXD FILM 45.3K OHM 1% 1/8W R:FXD FILM 45.3K OHM 1% 1/8W R:FXD FILM 1580 OHM 1% 1/8W	28480 28480 28480 28480 28480	0757-0453 0757-0453 0698-4496 0698-4496 0698-4426
A1R511B A1R512 A1R513 A1R514 A1R515	0698-4497 0698-3179 0757-0465 0757-0465 0698-4494	2 1 2 2 2	R:FXD FILM 6.04K OHM 1% 1/8W R:FXD FILM 2550 OHM 1% 1/8W R:FXD MET FILM 100K OHM 1% 1/8W R:FXD MET FILM 100K OHM 1% 1/8W R:FXD FILM 35.7K OHM 1% 1/8W	28480 28480 28480 28480 28480	0698-4497 0698-3179 0757-0465 0757-0465 0698-4494
A1R516 A1R517 A1R518 A1R519 A1R520	0698-4499 0698-4499 0757-0465 0757-0283 0757-0388	2 2 2 3	R:FXD FILM 56.9K OHM 1% 1/8W R:FXD FILM 56.9K OHM 1% 1/8W R:FXD MET FILM 100K OHM 1% 1/8W R:FXD MET FILM 2.00K OHM 1% 1/8W R:FXD FILM 30.1 OHM 1% 1/8W	28480 28480 28480 28480 28480	0698-4499 0698-4499 0757-0465 0757-0283 0757-0388
A1R521 A1R522 A1R523 A1R524 A1R525	0757-0388 2100-3270 0757-0446 0757-0446 0698-6324	3 1	R:FXD FILM 30.1 OHM 1% 1/8W R:VAR CERMET 100 OHM 10% 1/2W R:FXD MET FILM 15.0K OHM 1% 1/8W R:FXD MET FILM 15.0K OHM 1% 1/8W R:FXD FILM 187 OHM 1% 1/8W	28480 28480 28480 28480 28480	0757-0388 2100-3270 0757-0446 0757-0446 0698-6324

Δ Refer to Backdating Sec. VIII

See introduction to this section for ordering information

Table 6-1. Replaceable Parts(Cont'd)

Reference Designation	HP Part Number	Qty	Description	Mfr Code	Mfr Part Number
A1R526	0757-0346		R:FXD MET FLM 10 OHM 1% 1/8W	28480	0757-0346
A1R527	0698-4196	1	R:FXD FLM 1.07K OHM 1.0% 1/8W	28480	0698-4196
A1R528	0757-0346		R:FXD MET FLM 10 OHM 1% 1/8W	28480	0757-0346
A1U1	1820-0511	2	IC:TTL QUAD 2-INPT AND GATE	01295	SN7408N
A1U2	1820-0798	1	IC:TTL SIX DECADE	28480	1820-0798
A1U3	1820-0567	2	IC:TTL DUAL VOLTAGE-CONTROLLED MULTIVI	04713	MC4024P
A1U4	1820-0077	8	IC:TTL DUAL D F/F	01295	SN7474N
A1U5	1820-0099	3	IC:TTL 4-BIT BINARY COUNTER	01295	SN7493N
A1U6	1820-0077		IC:TTL DUAL D F/F	01295	SN7474N
A1U7	1820-0788	4	IC:TTL HEX D-TYPE FLIP/FLOP WITH CLEAR	01295	SN35431
A1U8	1820-0125	1	IC:DUAL COMPARATOR AV=700 MIN.	12040	LM711C
† A1U9	1818-2055	1	IC:BIT-ROM (4096)	28480	1818-2055
A1U10	1820-0174	8	IC:TTL HEX INVERTER	01295	SN7404N
A1U11	1820-0077		IC:TTL DUAL D F/F	01295	SN7474N
A1U12	1820-0099		IC:TTL 4-BIT BINARY COUNTER	01295	SN7493N
A1U13	1820-0591	4	IC:TTL LP 4W 3-2-2-3 INPT. AND OR GATE	12040	DM74LS4N
A1U14	1820-0077		IC:TTL DUAL D F/F	01295	SN7474N
A1U15	1820-0622	3	IC:TTL 8-INPT MULTIPLEXER W/ENABLE	01295	SN74151N
A1U16	1820-0702	1	IC:TTL LOW POWER 1 OF 16 DECODER	07263	U6N93L1159X
A1U17	1820-0077		IC:TTL DUAL D F/F	01295	SN7474N
A1U18	1820-0591		IC:TTL LP 4W 3-2-2-3 INPT. AND OR GATE	12040	DM74LS4N
A1U19	1820-0622		IC:TTL 8-INPT MULTIPLEXER W/ENABLE	01295	SN74151N
A1U20	1820-0077		IC:TTL DUAL D F/F	01295	SN7474N
A1U21	1820-0233	1	IC:TTL SYNUP-ON 4-BIT BINARY COUNTER	01295	SN74193N
A1U22	1820-0077		IC:TTL DUAL D F/F	01295	SN7474N
A1U23	1820-0586	15	IC:TTL LP HEX INVERTER	12040	DM74L04N
A1U24	1820-0622		IC:TTL 8-INPT MULTIPLEXER W/ENABLE	01295	SN74151N
A1U101	1820-0196	1	IC:LINEAR VOLTAGE REGULATOR(INPUT)	28480	1820-0196
A1U102	1820-0223	3	INTEGRATED CIRCUIT:OPERATIONAL AMPL.	28480	1820-0223
A1U103	1820-0203	2	IC:OPERATIONAL AMPLIFIFR	07263	SI 8940
A1U201	1826-0038	1	IC:LIN OPERATIONAL AMPL	04713	MC1436G
A1U202	1820-0223		INTEGRATED CIRCUIT:OPERATIONAL AMPL.	28480	1820-0223
A1U203	1820-0321	1	INTEGRATED CIRCUIT:HI-SPEED COMPARATOR	01295	SN72 710L
A1U301	1826-0009	1	IC:LINEAR OP. AMPL.	28480	1826-0009
A1U302	1826-0330		IC: LM 299 REF AMPL	27014	LM299H
A1U303	1826-0009		IC: UA 725C OP AMP	07283	725 HC
† A1U401	1818-2056	1	MOS:IN-CHANNEL ROM	28480	1818-2056
A1U402	1820-0583	6	IC:TTL LP QUAD 2-INPT NAND GATE	12040	DM74L00N
A1V1	0410-0465	1	CRYSTAL:QUARTZ 4 MHZ (60 HZ OPTION)	28480	0410-0465
A1V2	0410-0466	1	CRYSTAL: QUARTZ 3.333MHZ (50 HZ OPTION)	28480	0410-0466
A1A1	03490-66521	1	BOARD ASSY:VERTICAL	28480	03490-66521
A1A1R106	2100-3263	1	R:VAR 1K OHM 10%	28480	2100-3263
A1A1R210	2100-3310	1	R:VAR CERMET 1K OHM 10% TYPE P 3/4W	28480	2100-3310
A1A1R225	2100-3257		R:VAR 20K OHM 10%	28480	2100-3257
A1A1R228	2100-3257		R:VAR 20K OHM 10%	28480	2100-3257
A1A1R311	2100-3307	1	R:VAR CERMET 20K OHM 10% TYPE P 3/4W	28480	2100-3307
A1A1R317	2100-3315	1	R:VAR CERMET 20 OHM 10% TYPE P 3/4W	28480	2100-3315

‡ Refer to Backdating Sec. VIII

See introduction to this section for ordering information

Table 6-1. Replaceable Parts(Cont'd)











Reference Designation	HP Part Number	Qty	Description	Mfr Code	Mfr Part Number
			A2 ASSEMBLY SHOULD NOT BE REPAIRED TO COMPONENT LEVEL. THIS ASSEMBLY IS A REPAIR EXCHANGE ASSEMBLY.		
A3	03490-66543 			28480	28480
A3	03490-66543		PC ASSY-DISPLAY	28480	03490-66543
A3C1	0180-0197		C:FXD 2.2UF 10% 20VDCW	56289	150D225X9020A2 CYS
A3C2	0180-0197 		C:FXD 2.2UF 10% 20VDC	56289	150D225X9020A2 CYS
	03490-24302		MASK-ANN	28480	03490-24302
	03490-26543		PC BD-DISPLAY	28480	03490-26543
	03490-61601		CBL ASSY-DSPL	28480	03490-61601
A3DS1	1990-0533		LED-HI EFF	28480	1990-0533
A3DS3	1990-0533		LED-HI EFF HOUSING-ANN	28480	1990-0533
A3DSM1-6	1990-0531		7 SEG DIGIT	28480	1990-0531
A3DSM7	1990-0532		POLARITY DSPL	28480	1990-0532
A301 6	1853-0016		TSTR:PNP SCHMITT 2N3638 SI	80131	2N3638
A3U1	1820-1416		IC:DIGITAL SN74LS14N	01295	SN74LS14N
A3U2	1820-0595		IC:FLIP-FLOP	27014	DM74L73N
A3U3	1820-1416		IC:DIGITAL SN74LS14N	01295	SN74LS14N
A3U4	1820-0491		IC:TTL BCD/DEC	01295	SN74145N
A3U5	1820-0995		IC:TTL DECODER	01295	SN7447AN
A3U6-8	1820-1187 		IC:DIGITAL SN74LS00N	01295	SN74LS00N
A3R1-R8	0683-1215 		R:FXD COMP 120 OHM 5% 1/4W	01121	CB 1215
A3R9-R14	0683-1015 		R: 100 5% .25W	01121	CB 1015
A3R15	0683-3015 		R: 300 5% .25W	01121	CB 3015
A3R16	0683-1215 		R: 120 5% .25W	01121	CB 1215
A3R17	0683-1815 		R: 180 5% .25W	01121	CB 1815
A3R18	0683-6205 		R: 62 5% .25W	01121	CB 6205
A3R19	0687-2211		R:FXD COMP 220 OHM 10% 1/2W	01121	EB 2211
A3R20-R25	0683-1215		R:FXD COMP 120 OHM 5% 1/4W	01121	CB 1215
A3R30	0683-8205		R:FXD COMP 82 OHM 5% 1/4W	01121	CB 8205
A3CR1	1910-0016 		DIODE: GE 60V 60NA 1US	28480	1910-0016

Table 6-1. Replaceable Parts(Cont'd)

Reference Designation	HP Part Number	Qty	Description	Mfr Code	Mfr Part Number
A4	03490-66504	1	BOARD ASSY:REMOTE JUMPER	28480	03490-66504
A4MP1	4040-0748		EXTRACTOR:PC BOARD, BLACK	28480	4040-0748
A4MP2	4040-0755	3	EXTRACTOR:PC BOARD, VIOLET	28480	4040-0755
A5	03490-66505	1	BOARD ASSY:RANGE SWITCH	28480	03490-66505
A5R1	0684-2221		R:FXD COMP 2200 OHM 10% 1/4W	01121	CB 2221
A5R2	0684-2221		R:FXD COMP 2200 OHM 10% 1/4W	01121	CB 2221
A5R3	0684-2221		R:FXD COMP 2200 OHM 10% 1/4W	01121	CB 2221
A5R4	0684-2221		R:FXD COMP 2200 OHM 10% 1/4W	01121	CB 2221
A5R5	0684-2221		R:FXD COMP 2200 OHM 10% 1/4W	01121	CB 2221
A5R6	0684-2221		R:FXD COMP 2200 OHM 10% 1/4W	01121	CB 2221
A5R7	0684-2221		R:FXD COMP 2200 OHM 10% 1/4W	01121	CB 2221
A5R8	0684-2221		R:FXD COMP 2200 OHM 10% 1/4W	01121	CB 2221
A5R9	0684-2221		R:FXD COMP 2200 OHM 10% 1/4W	01121	CB 2221
A5S4	3101-1719	1	SWITCH: PUSHBUTTON	28480	3101-1719
A5W2	03490-61605	1	CABLE ASSY:RANGE	28480	03490-61605
A6	03490-66506	1	BOARD ASSY:CONVERTER AC	28480	03490-66506
A6C1	0160-0904	1	C:FXD CER 0.05 UF 20% 100VDCW	56289	41C 169A4-COH
A6C2	0160-3976	1	C:FXD 10 PF 500VDCW	28480	0160-3976
A6C3	0160-3930	1	C:FXD 10 PF 250J VDCW	28480	0160-3930
A6C4	0140-0202	1	C:FXD MICA 15 PF 5% 500VDCW	28480	0140-0202
A6C5	0160-3977	1	C:FXD 970 PF 0.1	28480	0160-3977
A6C6	0121-0436	1	C:VAR AIR 2.4-24.5 PF	74970	189-509-105
A6C7	0160-3622	6	C:FXD CER 0.1 UF +80-20% 100VDCW	72982	8131-100-651-1042
A6C8	0160-3622		C:FXD CER 0.1 UF +80-20% 100VDCW	72982	8131-100-651-1042
A6C10	0160-3622		C:FXD CER 0.1 UF +80-20% 100VDCW	72982	8131-100-651-1042
A6C11	0160-3622		C:FXD CER 0.1 UF +80-20% 100VDCW	72982	8131-100-651-1042
A6C12	0150-0084		C:FXD CER 0.1 UF +80-20% 100VDCW	72982	8131-100-651-1042
A6C13	0150-0084		C:FXD CER 0.1 UF +80-20% 100VDCW	72982	8131-100-651-1042
A6C14	0150-0093		C:FXD CER 0.01 UF +80-20% 100VDCW	72982	801-K800011
A6C15	0150-0093		C:FXD CER 0.01 UF +80-20% 100VDCW	72982	801-K800011
A6C16	0160-2134	2	C:FXD MY 0.48 UF 10% 50VDCW	56289	148P350
A6C17	0150-0093		C:FXD CER 0.01 UF +80-20% 100VDCW	72982	801-K800011
A6C18	0150-0093		C:FXD CER 0.01 UF +80-20% 100VDCW	72982	801-K800011
A6C19	0160-0181		C:FXD MICA 30PF 5% 300VDCW	14655	RDM156300J35
A6C20	0150-0093		C:FXD CER 0.01 UF +80-20% 100VDCW	72982	801-K800011
A6C21	0180-0229	3	C:FXD FILT 33 UF 10% 10VDCW	28480	0180-0229
A6C22	0180-0229		C:FXD FILT 33 UF 10% 10VDCW	28480	0180-0229
A6C23,C24	0180-0876	2	C:FXD TA 82 UF 20% 10VDCW	28480	0180-0876
A6C25	0160-3945	1	C:FXD PORG 39 PF 1% 500VDCW	28480	0160-3945
A6C26	0160-3949	1	C:FXD PORG 346 PF 1% 500VDCW	28480	0160-3949
A6C27	0121-0432	2	C:VAR AIR 1.7-14.1 PF	74970	189-505-105
A6C28	0160-0763	1	C:FXD MICA 5 PF 10% 500VDCW	00853	RDM156050K55
A6C29	0160-0859	2	C:FXD MY 1 UF 10% 50VDCW	56289	148P335 PUM
A6C30	0160-2134		C:FXD MY 0.48 UF 10% 50VDCW	56289	148P350
A6C31	0160-3501	1	C:FXD POLY 4 UF 10% 50VDCW	84411	HFV 138
A6C32	0160-0859		C:FXD MY 1 UF 10% 50VDCW	56289	148P335 PUM
A6C33,C34	0180 0127	2	C:FXD CER 1 UF 20% 25VDCW	56289	5C13CS-DML
A6C35	0160 3622	1	C:FXD CER 0.1 UF 100VDCW	28480	0160-3622
A6CR1	1901-0040		DIODE:SI LICON 50 MA 30 WV	07263	FDG1088
A6CR2	1901-0040		DIODE:SI LICON 50 MA 30 WV	07263	FDG1088
A6CR3	1901-0040		DIODE:SI LICON 50 MA 30 WV	07263	FDG1088
A6CR4	1901-0040		DIODE:SI LICON 50 MA 30 WV	07263	FDG1088
A6CR5	1901-0047	6	DIODE JUNCTION:SI LICON 20PIV	28480	1901-0047
A6CR6	1901-0047		DIODE JUNCTION:SI LICON 20PIV	28480	1901-0047
A6CR7	1901-0047		DIODE JUNCTION:SI LICON 20PIV	28480	1901-0047
A6CR8	1901-0047		DIODE JUNCTION:SI LICON 20PIV	28480	1901-0047
A6CR9	1902-0041		DIODE:BR FAKDOWN 5-11V 5%	04713	S710939-08
A6CR10	1902-0041		DIODE:BR FAKDOWN 5-11V 5%	04713	S710939-08
A6CR11	1901-0047		DIODE JUNCTION:SI LICON 20PIV	28480	1901-0047
A6CR12	1901-0047		DIODE JUNCTION:SI LICON 20PIV	28480	1901-0047
A6CR13	1902-3162	1	DIODE BR FAKDOWN:SI LICON 12.1V 5%	28480	1902-3162

⚠ Refer to Backdating Sec. VIII

See introduction to this section for ordering information

Table 6-1. Replaceable Parts(Cont'd)

Reference Designation	HP Part Number	Qty	Description	Mfr Code	Mfr Part Number
A6CR14	1901-0518	3	DIODE:HOT CARRIER	28480	1901-0518
A6CR15	1901-0518		DIODE:HOT CARRIER	28480	1901-0518
A6CR16	1901-0586	3	DIODE:SI 30 WV 10 PA LEAKAGE	28480	1901-0586
A6CR17	1901-0040		DIODE:SILICON 50 MA 30 WV	07263	FDG1088
A6CR18	1901-0040		DIODE:SILICON 50 MA 30 WV	07263	FDG1088
A6CR15	1901-0040		DIODE:SILICON 50 MA 30 WV	07263	FDG1088
A6K1	0490-1105		SWITCH:RFFD	28480	0490-1105
A6K2	0490-1105		SWITCH:RFFD	28480	0490-1105
A6K3	0490-1105	1	RELAY-REED 1A 500MA 1200VAC 3.5VDC - COIL	28480	0490-1105
A6K4	0490-0778	6	SWITCH:RFFD MAGNETIC, MINIATURE	28480	0490-0778
A6L1	0490-1083	3	COIL ASSY:RFFD RELAY	09026	P.S. 3001-95
A6MP1-17	0340-0060		FFFDTHRU:INSULATED MOUNTING	28480	0340-0060
A6MP18	0380-0938	1	SPACER:TEFLON 0.128" DIA HOLE	98291	R-1451-1
A6MP19	1200-0437		SOCKET:IC 8 PIN	17117	5566-235-5
A6MP20	1400-0760		CLIP:MOUNTING ASSY(SET OF 3)	28480	1400-0760
A6MP21	1400-0760		CLIP:MOUNTING ASSY(SET OF 3)	28480	1400-0760
A6MP22	1400-0760		CLIP:MOUNTING ASSY(SET OF 3)	28480	1400-0760
A6MP23	1400-0760		CLIP:MOUNTING ASSY(SET OF 3)	28480	1400-0760
A6MP24	1400-0760		CLIP:MOUNTING ASSY(SET OF 3)	28480	1400-0760
A6MP25	1400-0760		CLIP:MOUNTING ASSY(SET OF 3)	28480	1400-0760
A6MP26	1400-0760		CLIP:MOUNTING ASSY(SET OF 3)	28480	1400-0760
A6MP27	1400-0760		CLIP:MOUNTING ASSY(SET OF 3)	28480	1400-0760
A6MP28	1400-0760		CLIP:MOUNTING ASSY(SET OF 3)	28480	1400-0760
A6MP29	1600-0273	1	STAMPING:BRASS	28480	1600-0273
A6MP30	1600-0274	1	STAMPING:BRASS	28480	1600-0274
A6MP31	1600-0275	3	SHIELD:POT	28480	1600-0275
A6MP32	1600-0275		SHIELD:POT	28480	1600-0275
A6MP33	1600-0275		SHIELD:POT	28480	1600-0275
A6MP34	4040-0748		EXTRACTOR:PC BOARD, BLACK	28480	4040-0748
A6MP35	4040-0750	1	EXTRACTOR:PC BOARD, RED	28480	4040-0750
A6MP36	0360-1803	13	TERMINAL:SOLDER LUG	00000	080
A6MP37	0360-1803		TERMINAL:SOLDER LUG	00000	080
A6MP38	0360-1803		TERMINAL:SOLDER LUG	00000	080
A6MP39	0360-1803		TERMINAL:SOLDER LUG	00000	080
A6O1	1853-0010		TSTR:SI NPN(SELCTED FROM 2N3251)	28480	1853-0010
A6O2	1855-0383	1	TSTR:DUAL FET SI N-CHANNEL	28480	1855-0383
A6O3	1854-0071		TSTR:SI NPN(SELCTED FROM 2N3704)	28480	1854-0071
A6O4	1853-0010		TSTR:SI NPN(SELCTED FROM 2N3251)	28480	1853-0010
A6O5	1854-0071		TSTR:SI NPN(SELCTED FROM 2N3704)	28480	1854-0071
A6O6	1854-0071		TSTR:SI NPN(SELCTED FROM 2N3704)	28480	1854-0071
A6O7	1855-0377	2	TSTR:FET SI N-CHANNEL	28480	1855-0377
A6O8	1853-0010		TSTR:SI NPN(SELCTED FROM 2N3251)	28480	1853-0010
A6O9	1855-0377		TSTR:FET SI N-CHANNEL	28480	1855-0377
A6O10	1853-0010		TSTR:SI NPN(SELCTED FROM 2N3251)	28480	1853-0010
A6R1A, R1B	0698-8216	1	R:MATCHED SET	28480	0698-8216
A6R3	2100-3311	2	R:VAR CERMFT 500 OHM 10% TYPE P 3/4W	28480	2100-3311
A6R4A, R4B, R4C	0698-8215	1	R:MATCHED SET	28480	0698-8215
A6R5	0684-4721		R:FXD COMP 4700 OHM 10% 1/4W	01121	CB 4721
A6R6	0684-4721		R:FXD COMP 4700 OHM 10% 1/4W	01121	CB 4721
A6R7	0698-3558	2	R:FXD MET FLM 4.02K OHM 1% 1/8W	28480	0698-3558
A6R8	0698-3558		R:FXD MET FLM 4.02K OHM 1% 1/8W	28480	0698-3558
A6R9	0757-0410	3	R:FXD MET FLM 301 OHM 1% 1/8W	28480	0757-0410
A6R10	0757-0410		R:FXD MET FLM 301 OHM 1% 1/8W	28480	0757-0410
A6R11	0698-3497		R:FXD FLM 6.04K OHM 1% 1/8W	28480	0698-3497
A6R12	0698-4489	1	R:FXD FLM 28K OHM 1% 1/8W	28480	0698-4489
A6R13	0757-0430	1	R:FXD MET FLM 2.21K OHM 1% 1/8W	28480	0757-0430
A6R14	0684-1021		R:FXD COMP 1000 OHM 10% 1/4W	01121	CB 1021
A6R15	0684-1021		R:FXD COMP 1000 OHM 10% 1/4W	01121	CB 1021
A6R16	0698-4467	2	R:FXD FLM 1.05K OHM 1% 1/8W	28480	0698-4467
A6R17	0757-0449	10	R:FXD FLM 20K OHM 1% 1/8W	28480	0757-0449
A6R18	0698-4308	1	R:FXD MET FLM 16.9K OHM 1% 1/8W	28480	0698-4308
A6R19	0757-0200	1	R:FXD MET FLM 5.62K OHM 1% 1/8W	28480	0757-0200
A6R20	0757-0401		R:FXD MET FLM 100 OHM 1% 1/8W	28480	0757-0401
A6R21	0698-4488	2	R:FXD FLM 26.7K OHM 1% 1/8W	28480	0698-4488
A6R22	0757-0453		R:FXD MET FLM 30.1K OHM 1% 1/8W	28480	0757-0453
A6R23	0757-0270	1	R:FXD MET FLM 249K OHM 1% 1/8W	28480	0757-0270
A6R24	0698-4488		R:FXD FLM 26.7K OHM 1% 1/8W	28480	0698-4488

See introduction to this section for ordering information

Table 6-1. Replaceable Parts(Cont'd)

Reference Designation	HP Part Number	Qty	Description	Mfr Code	Mfr Part Number
A6R25	0757-0453		R:FXD MET FLM 30.1K OHM 1% 1/8W	28480	0757-0453
A6R26	0698-3548	1	R:FXD FLM 732 OHM 1% 1/8W	28480	0698-3548
A6R27	2100-3306	2	R:VAR CERMET 50K OHM 10% TYPE P 3/4W	28480	2100-3306
A6R28	2100-3308	1	R:VAR CERMET 5K OHM 10% TYPE P 3/4W	28480	2100-3308
A6R29A, R29B	0698-8214	1	R:MATCHED SFT	28480	0698-8214
A6R30	0698-3495	1	R:FXD MET FLM 866 OHM 1% 1/8W	28480	0698-3495
A6R31	0698-4467		R:FXD FLM 1.05K OHM 1% 1/8W	28480	0698-4467
A6R32	2100-3309	2	R:VAR CERMET 2K OHM 10% TYPE P 3/4W	28480	2100-3309
A6R33	0757-0457		R:FXD MET FLM 47.5K OHM 1% 1/8W	28480	0757-0457
A6R34	0757-0453		R:FXD MET FLM 30.1K OHM 1% 1/8W	28480	0757-0453
A6R35	0698-4514	1	R:FXD FLM 105K OHM 1% 1/8W	28480	0698-4514
A6R36	0757-0454	1	R:FXD MET FLM 33.2K OHM 1% 1/8W	28480	0757-0454
A6R37	0698-3228		R:FXD MET FLM 40.9K OHM 1% 1/8W	28480	0698-3228
A6R38	0757-0436	2	R:FXD MET FLM 4.32K OHM 1% 1/8W	28480	0757-0436
A6R39	0698-3540	2	R:FXD MET FLM 15.4K OHM 1% 1/8W	28480	0698-3540
A6R40	0698-1541		R:FXD COMP 15K OHM 10% 1/4W	01121	CB 1531
A6R41	0698-3228		R:FXD MET FLM 40.9K OHM 1% 1/8W	28480	0698-3228
A6R42	0757-0436		R:FXD MET FLM 4.32K OHM 1% 1/8W	28480	0757-0436
A6R43	0698-3540		R:FXD MET FLM 15.4K OHM 1% 1/8W	28480	0698-3540
A6R44	0698-4497	1	R:FXD MET FLM 48.7K OHM 1% 1/8W	28480	0698-4497
A6R45, R46	0683-3325	6	R:FXD COMP 3300 OHM 5% 1/4W	01121	CB 3325
A6U1	1820-0054		IC:TTL DUAL 2-INPT NAND GATE	01295	SN7400N
A6U2	1820-0049	1	IC:TTL DUAL 4-INPT PDS NAND GATE	01295	SN7420N
A6U3	1826-0089	1	AMPLIFIER-INFR	28480	1826-0089
A6U4	1820-0203		IC:OPERATIONAL AMPLIFIER	07263	SI 8940
A6U5	1820-0579	1	IC:RCVR	28480	1820-0579
A7	03490-66507	1	BOARD ASSY:OHM CONVERTER	28480	03490-66507
A7	03490-69507		REBUILT OHMS CONVERTER ASSY	28480	03490-69507
A7C1	0150-0073	2	C:FXD CER 100 PF 10% 1000VDCW	56289	CO288102E101KS27-CDH
A7C2	0150-0073		C:FXD CER 100 PF 10% 1000VDCW	56289	CO288102E101KS27-CDH
A7C3	0180-1701		C:FXD ELFCT 6.8K OHM 20% 6VDCW	28480	0180-1701
A7C4	0170-0021		C:FXD MY 4700PF 20% 400VDCW	84411	66310W47294
A7C5	0180-0230	1	C:FXD ELFCT 150UF 20% 50VDCW	56289	150J105X0050A2-DYS
A7C6	0150-0194	4	C:FXD MY 0.015 UF 10%	56289	192P15392-PTS
A7C7	0150-0071	1	C:FXD CER 100 PF 5% 100VDCW	56289	CO16R102E401J527-CDH
A7CR1	1901-0040		DIPDE:SI LICON 50 MA 30 WV	07263	FDG1088
A7CR2	1901-0040		DIPDE:SI LICON 50 MA 30 WV	07263	FDG1088
A7CR3	1907-3104		DIPDE:BRKAKDOWN 5.62V 5%	04713	SZ10939-110
A7CR4	1901-0040		DIPDE:SI LICON 50 MA 30 WV	07263	FDG1088
A7CR5	1901-0040		DIPDE:SI LICON 50 MA 30 WV	07263	FDG1088
A7CR6	1901-0040		DIPDE:SI LICON 50 MA 30 WV	07263	FDG1088
A7CR7	1901-0040		DIPDE:SI LICON 50 MA 30 WV	07263	FDG1088
A7CR8	1901-0040		DIPDE:SI LICON 50 MA 30 WV	07263	FDG1088
A7CR9	1901-0040		DIPDE:SI LICON 50 MA 30 WV	07263	FDG1088
A7CR10	1901-0040		DIPDE:SI LICON 50 MA 30 WV	07263	FDG1088
A7CR11	1901-0028		DIPDE:SI LICON 0.75A 400PIV	04713	SR1358-9
A7DS1	1970-0052	1	TUBE:VOLTAGE PROTECTOR 90V 20%	28480	1970-0052
A7K1	0490-0778		SWITCH:REFD MAGNETIC, MINIATURE	28480	0490-0778
A7K2	0490-0778		SWITCH:REFD MAGNETIC, MINIATURE	28480	0490-0778
A7K3	0490-0778		SWITCH:REFD MAGNETIC, MINIATURE	28480	0490-0778
A7K4	0490-0778		SWITCH:REFD MAGNETIC, MINIATURE	28480	0490-0778
A7K5	0490-0778		SWITCH:REFD MAGNETIC, MINIATURE	28480	0490-0778
A7L1	0490-1033	3	RELAY/COIL, REFD	28480	0490-1033
A7L2	0490-1033		RELAY/COIL, REFD	28480	0490-1033
A7L3	0490-1033		RELAY/COIL, REFD	28480	0490-1033
A7L4	0490-1083		COIL ASSY:REFD RELAY	09026	P.S. 3001-55
A7L5	0490-1083		COIL ASSY:REFD RELAY	09026	P.S. 3001-55
A7MP1	1400-0760		CLIP:MOUNTING ASSY(SET OF 3)	28480	1400-0760
A7MP2	1400-0760		CLIP:MOUNTING ASSY(SET OF 3)	28480	1400-0760
A7MP3	1400-0760		CLIP:MOUNTING ASSY(SET OF 3)	28480	1400-0760
A7MP4	1400-0760		CLIP:MOUNTING ASSY(SET OF 3)	28480	1400-0760
A7MP5	1400-0760		CLIP:MOUNTING ASSY(SET OF 3)	28480	1400-0760
A7MP6	1400-0760		CLIP:MOUNTING ASSY(SET OF 3)	28480	1400-0760
A7MP7	1400-0760		CLIP:MOUNTING ASSY(SET OF 3)	28480	1400-0760
A7MP8	1400-0760		CLIP:MOUNTING ASSY(SET OF 3)	28480	1400-0760
A7MP9	1400-0760		CLIP:MOUNTING ASSY(SET OF 3)	28480	1400-0760
A7MP10	1400-0760		CLIP:MOUNTING ASSY(SET OF 3)	28480	1400-0760

△ Refer to Backdating Sec. VIII

See introduction to this section for ordering information

Table 6-1. Replaceable Parts(Cont'd)

Reference Designation	HP Part Number	Qty	Description	Mfr Code	Mfr Part Number
A7MP11	0360-1803		TERMINAL:SOLDER LUG	00000	080
A7MP12	0360-1803		TERMINAL:SOLDER LUG	00000	080
A7MP13	0360-1803		TERMINAL:SOLDER LUG	00000	080
A7MP14	0360-1803		TERMINAL:SOLDER LUG	00000	080
A7MP15	0360-1803		TERMINAL:SOLDER LUG	00000	080
A7MP16	0360-1803		TERMINAL:SOLDER LUG	00000	080
A7MP17	0360-1803		TERMINAL:SOLDER LUG	00000	080
A7MP18	0360-1803		TERMINAL:SOLDER LUG	00000	080
A7MP19	0360-1803		TERMINAL:SOLDER LUG	00000	080
A7MP2C	4040-0748		EXTRACTOR:PC BOARD, BLACK	28480	4040-0748
A7MP21	4040-0751	1	EXTRACTOR:PC BOARD, ORANGE	28480	4040-0751
A701	1854-0087		TSTR:SI NPN	80131	2N3417
A702	1854-0087		TSTR:SI NPN	80131	2N3417
A703	1853-0086		TSTR:SI PNP	80131	2N5087
A704	1853-0012	1	TSTR:SI PNP	80131	2N2904A
A705	1854-0087		TSTR:SI NPN	80131	2N3417
A706	1855-0308		TSTR:SI NPN DUAL	28480	1855-0308
A707	1853-0086		TSTR:SI PNP	80131	2N5087
A7R1	0684-4721		R:FXD COMP 4700 OHM 10% 1/4W	01121	CR 4721
A7R2	0684-4721		R:FXD COMP 4700 OHM 10% 1/4W	01121	CR 4721
A7R3	0698-3264		R:FXD FIM 11.8K OHM 1% 1/8W	28480	0698-3264
A7R4	0757-0280		R:FXD MET FLM 1K OHM 1% 1/8W	28480	0757-0280
A7R5	2100-1738	1	R:VAR FIM 10K OHM 10% 1/2W	28480	2100-1738
A7R6	0698-4430	1	R:FXD FIM 1.91K OHM 1% 1/8W	28480	0698-4430
A7R7	0757-0465		R:FXD MET FLM 100K OHM 1% 1/8W	28480	0757-0465
A7R9	0684-1031	32	R:FXD COMP 10K OHM 10% 1/4W	01121	CR 1031
A7R10	0684-1031		R:FXD COMP 10K OHM 10% 1/4W	01121	CR 1031
A7R11	0684-4711		R:FXD COMP 470 OHM 10% 1/4W	01121	CR 4711
A7R12	0757-0472		R:FXD MET FLM 200K OHM 1% 1/8W	28480	0757-0472
A7R13	0811-3216	1	R:FXD MW 1.0040K OHM 0.02% 1/8W	28480	0811-3216
A7R14	2100-3304	1	R:VAR CERMET 200K OHM 10% TYPE P 3/4W	28480	2100-3304
A7R15	0811-3217	1	R:FXD MW 88.90K OHM 0.02% 1/8W	28480	0811-3217
A7R16	2100-3312	1	R:VAR CERMET 200 OHM 10% TYPE P 3/4W	28480	2100-3312
A7R17	0811-3215	1	R:FXD MW 899K OHM 0.05% 1/4W	28480	0811-3215
A7R18	2100-3309		R:VAR CERMET 2K OHM 10% TYPE P 3/4W	28480	2100-3309
A7R19	0757-0453		R:FXD MET FLM 30.1K OHM 1% 1/8W	28480	0757-0453
A7R20	0757-0453		R:FXD MET FLM 30.1K OHM 1% 1/8W	28480	0757-0453
A7R21	0757-0453		R:FXD MET FLM 30.1K OHM 1% 1/8W	28480	0757-0453
A7R22	0684-2721		R:FXD COMP 2700 OHM 10% 1/4W	01121	CR 2721
A7R23	0684-6821		R:FXD COMP 6.8K OHM 10% 1/4W	01121	CR 6821
A7R24	0811-0006	1	R:FXD MW 5000 OHM 1% 5W	28480	0811-0006
A7R25	0684-1021		R:FXD COMP 1000 OHM 10% 1/4W	01121	CR 1021
A7T1	9100-1441	1	TRANSFORMER:STEP-UP	28480	9100-1441
A7U1	1820-0056	1	IC:TTL DIVIDE BY 12 10 MHZ MIN.	01295	SN7492N
A7U2	1820-0054	1	IC:TTL QUAD 2-INPUT NAND GATE	01295	SN7400N
A7U3	1820-0094	1	IC:DTL QUAD 2-INPUT GATE	04713	SC6903PK
A7U4	1820-0478	1	IC:LINEAR OPERATIONAL AMPLIFIER	12040	LM 308H
A8	03490-66508	1	OUTGUARD POWER SUPPLY BOARD ASSY	28480	03490-66508
A8C1	0180-0197		C:FXD ELECT 2.2 UF 10% 20VDCW	56289	150D225X9020A2-0Y5
A8C2	0810-0650	5	C:FXD AL ELECT 390 MF 20VDCW	28480	0810-0650
A8C3	0810-0650		C:FXD AL ELECT 390 MF 20VDCW	28480	0810-0650
A8C4	0150-0050		C:FXD CER 1000 PF +80-20% 1000VDCW	56289	C0678102E102Z526-C0H
A8C5	0170-0040		C:FXD MY 0.047 UF 10% 200VDCW	56289	192P47392-PTS
A8C6	0150-0050		C:FXD CER 1000 PF +80-20% 1000VDCW	56289	C0678102E102Z526-C0H
A8CR1	1901-0363	3	DIODE ASSY:SI 100 PIV PER CELL	28480	1901-0363
A8CR2	1901-0040		DIODE:SILICON 50 MA 30 WV	07263	FD61088
A8CR3	1901-0158	1	DIODE:SILICON 0.75A 200 PIV	28480	1901-0158
A8J9	1251-1365	5	CONN:PC 44 (2X22) CONTACTS	71785	252-22-30-300

Δ Refer to Backdating Sec. VIII

See introduction to this section for ordering information

















Table 6-1. Replaceable Parts(Cont'd)

Reference Designation	HP Part Number	Qty	Description	Mfr Code	Mfr Part Number
ABJ10	1251-1365	8	CONN:PC 44 (2X22) CONTACTS	71785	252-22-30-300
ABPP1	5040-0170		GUIDE:PLUG-IN PC BOARD	28480	5040-0170
ABMP2	5040-0170		GUIDE:PLUG-IN PC BOARD	28480	5040-0170
ABMP3	5040-0170		GUIDE:PLUG-IN PC BOARD	28480	5040-0170
ABMP4	5040-0170		GUIDE:PLUG-IN PC BOARD	28480	5040-0170
ABMP5	03490-01209	1	BRACKET: MOUNTING CONNECTOR	28480	03490-01209
ABMP6	1251-2551		CONNECTOR:SINGLE CONTACT MINIATURE	00779	332070
ABMP7	1251-2551		CONNECTOR:SINGLE CONTACT MINIATURE	00779	332070
ABMP8	1251-2551		CONNECTOR:SINGLE CONTACT MINIATURE	00779	332070
ABMP9	1251-2551		CONNECTOR:SINGLE CONTACT MINIATURE	00779	332070
ABPPI0	1251-2551	1	CONNECTOR:SINGLE CONTACT MINIATURE	00779	332070
ABPPI1	1251-2551		CONNECTOR:SINGLE CONTACT MINIATURE	00779	332070
ARG1	1854-0071		TSTR:SI NPN(SELECTED FROM 2N3704)	28480	1854-0071
ARR1	0757-0410		R:FXD MET FILM 301 OHM 1% 1/8W	28480	0757-0410
ARR2	0698-4355		R:FXD FILM 12.4 OHM 1% 1/8W	28480	0698-4355
ARR3	0684-8221	9	R:FXD COMP 8200 OHM 10% 1/4W	01121	CR 8221
ARR4	0684-8221		R:FXD COMP 8200 OHM 10% 1/4W	01121	CR 8221
ARR5	0684-8221		R:FXD COMP 8200 OHM 10% 1/4W	01121	CR 8221
ARR6	0684-1011		R:FXD COMP 100 OHM 10% 1/4W	01121	CR 1011
ARR7	0684-2231		R:FXD COMP 22K OHM 10% 1/4W	01121	CR 2231
ARR8	0684-1231		R:FXD COMP 12K OHM 10% 1/4W	01121	CR 1231
ARR9	0684-1021		R:FXD COMP 1000 OHM 10% 1/4W	01121	CR 1021
ARR10	0684-1021	R:FXD COMP 1000 OHM 10% 1/4W	01121	CR 1021	
ARR11	0684-8221	R:FXD COMP 8200 OHM 10% 1/4W	01121	CR 8221	
ARU1	1820-0430	2	IC:LINEAR, VOLTAGE REGULATOR 5V	28480	1820-0430
ARU2	1820-0586		IC:TTL LP HEX INVERTFR	12040	DM74L04N
ARW4	03490-61603	1	CABLE ASSY:REM	28480	03490-61603
ARW5	03490-61604	1	CABLE ASSY:BCD	28480	03490-61604
A9	03490-66509	1	INGUARD DATA OUTPUT BOARD ASSY	28480	03490-66509
A9C1	0160-2009	2	C:FXD MICA 8200PF 5% 300VDCW	00853	RD15F821J3C
A9C2	0160-0197		C:FXD ELECT 2.2 UF 10% 20VDCW	56289	1500225X9020A2-DYS
A9C3	0160-0194	1	C:FXD MY 0.015 UF 10%	56289	192P15392-PTS
A9C4	0160-0194		C:FXD MY 0.015 UF 10%	56289	192P15392-PTS
A9C5	0160-0194		C:FXD MY 0.015 UF 10%	56289	192P15392-PTS
A9MP1	1200-0424	4	SOCKET:IC BLK 14 CONTACT	23880	CSA2900-148
A9MP2	4040-0747		EXTRACTOR:PC BOARD, GRAY	28480	4040-0747
A9MP3	4040-0748		EXTRACTOR:PC BOARD, BLACK	28480	4040-0748
A9R1	0684-3321	3	R:FXD COMP 3300 OHM 10% 1/4W	01121	CR 3321
A9R2	0684-3321		R:FXD COMP 3300 OHM 10% 1/4W	01121	CR 3321
A9R3	0684-3321		R:FXD COMP 3300 OHM 10% 1/4W	01121	CR 3321
A9R4	0684-1521		R:FXD COMP 1500 OHM 10% 1/4W	01121	CR 1521
A9R5	1810-0049		RESISTIVE NETWORK:10 X 6.8K OHM 10%	28480	1810-0049
A9U1	1820-0584	5	IC:TTL LP QUAD 2-INPT NOR GATE	12040	DM74L02N
A9U2	1820-0595		IC:TTL LP DUAL J-K MASTER SLAVE F/F	12040	DM74L73N
A9U3	1820-0584	1	IC:TTL LP QUAD 2-INPT NOR GATE	12040	DM74L02N
A9U4	1820-0594		IC:TTL J-K MASTER SLAVE F/F	12040	DM74L72N
A9U5	1820-0586	5	IC:TTL LP HEX INVERTFR	12040	DM74L04N
A9U6	1820-0710		IC:DIGITAL TTL+LOGIC 5V 5%	07263	SL17315
A9U7	1820-0710		IC:DIGITAL TTL+LOGIC 5V 5%	07263	SL17315
A9U8	1820-0583		IC:TTL LP QUAD 2-INPT NAND GATE	12040	DM74L00N
A9U9	1820-0710		IC:DIGITAL TTL+LOGIC 5V 5%	07263	SL17315
A10	03490-66510	1	OUTGUARD DATA OUTPUT BOARD ASSY	28480	03490-66510
A10C1	0160-0197	2	C:FXD FLECT 2.2 UF 10% 20VDCW	56289	1500225X9020A2-DYS
A10C2	0160-0298		C:FXD MY 0.0015 UF 10% 200VDCW	56289	192P15292-PTS
A10MP1	0403-0189	4	EXTRACTOR:PC, BLACK	28480	0403-0189
A10MP2	0403-0189		EXTRACTOR:PC, BLACK	28480	0403-0189
A10MP3	1200-0424	1	SOCKET:IC BLK 14 CONTACT	23880	CSA2900-148
A1001	1854-0071		TSTR:SI NPN(SELECTED FROM 2N3704)	28480	1854-0071
A10R1-33	0684-8221	1	R:FXD COMP 6.8K OHM 10% 1/4W	01121	CR 6821

△ Refer to Backdating Sec. VIII

See introduction to this section for ordering information

Table 6-1. Replaceable Parts(Cont'd)

Reference Designation	HP Part Number	Qty	Description	Mfr Code	Mfr Part Number
A10S1 A10S2	3101-1341 3101-1341	2	SWITCH:SLIDE SPDT 0.5A 125V AC/DC SWITCH:SLIDE SPDT 0.5A 125V AC/DC	79727 79727	C-111-0004 C-111-0004
A10U1 A10U2 A10U3 A10U4 A10U5	1820-0586 1820-0174 1820-0294 1820-0294 1820-0294	4	IC:TTL LP HEX INVERTER IC:TTL HEX INVERTER IC:TTL 8-BIT SER-IN PAR OUT SHIFT REG IC:TTL 8-BIT SER-IN PAR OUT SHIFT REG IC:TTL 8-BIT SER-IN PAR OUT SHIFT REG	12040 01295 12040 12040 12040	DM74L04N SN7474N SD9935 SD9935 SD9935
A10U6 A10U7	1820-0294 1820-0282	1	IC:TTL 8-BIT SER-IN PAR OUT SHIFT REG IC:TTL QUAD 2-INPT EXCL. OR GATE	12040 01295	SD9935 SN7486N
A11	03490-66511 	1	INGUARD REMOTE ASSY	28480	03490-66511
A11C1 A11C2 A11C3	0180-0197 0160-2009 0170-0066	2	C:FXD ELECT 2.2 UF 10% 20VDCW C:FXD MICA 820 PF 5% 300VDCW C:FXD MY 0.027 UF 10% 200VDCW	56289 03853 56289	1500225X9020A2-DYS RDM15F821J3C 192P27392-PTS
A11C4 A11C5 A11C6	0170-0066 0160-0164  0160-0298 	1	C:FXD MY 0.327 UF 10% 200VDCW C:FXD MY 0.039 UF 10% 200VDCW C:FXD MY 0.0015 UF 10% 200VDCW	56289 56289 56289	192P27392-PTS 192P39392-PTS 192P15292-PTS
A11MP1 A11MP2 A11MP3 A11Q1	1200-0424 4040-0748 4040-0755 1854-0071		SOCKET:IC BLK 14 CONTACT EXTRACTOR:PC BOARD, BLACK EXTRACTOR:PC BOARD, VIOLET TSTR:SI NPN(SUBJECTED FROM 2N3704)	23880 28480 28480 28480	CSA2900-148 4040-0748 4040-0755 1854-0071
A11R1 A11R2 A11R3 A11R4 A11R5	0684-4701 0684-1031 0684-3321  0684-6821  0684-3321		R:FXD COMP 47 OHM 10% 1/4W R:FXD COMP 10K OHM 10% 1/4W R:FXD COMP 330 OHM 10% 1/4W R:FXD COMP 6.8K OHM 10% 1/4W R:FXD COMP 330 OHM 10% 1/4W	01121 01121 01121 01121 01121	CB 4701 CB 1031 CB 3321 CB 6821 CB 3321
A11R6 A11R7 A11R8 A11R9 A11R1C	0684-3321 0684-1521 0684-6821 0684-6821 0684-6821		R:FXD COMP 330 OHM 10% 1/4W R:FXD COMP 1500 OHM 10% 1/4W R:FXD COMP 6.8K OHM 10% 1/4W R:FXD COMP 6.8K OHM 10% 1/4W R:FXD COMP 6.8K OHM 10% 1/4W	01121 01121 01121 01121 01121	CB 3321 CB 1521 CB 6821 CB 6821 CB 6821
A11R11	0684-6821 		R:FXD COMP 6.8K OHM 10% 1/4W	01121	CB 6821
A11U1 A11U2	1820-0586 1820-0586		IC:TTL LP HEX INVERTER IC:TTL LP HEX INVERTER	12040 12040	DM74L04N DM74L04N
A11U3 A11U4 A11U5 A11U6 A11U7	1820-0583 1820-0584 1820-0585 1820-0584  1820-0599 	2	IC:TTL LP QUAD 2-INPT NAND GATE IC:TTL LP QUAD 2-INPT NOR GATE IC:TTL LP DUAL J-K MASTER SLAVE F/F IC:TTL LP QUAD 2-INPUT NOR GATE IC:TTL 4-BIT RT/LT SHIFT REGISTER	12040 12040 12040 12040 12040	DM74L00N DM74L02N DM74L73N DM74L02N DM74L95N
A11U8 A11U9 A11U1C A11U11 A11U12	1820-0599  1820-0596  1820-1100  1820-0656  1820-0586 	11 1 7	IC:TTL 4-BIT RT/LT SHIFT REGISTER IC:TTL LP DUAL EDGE TRIG. D F/F IC:TTL IC:TTL LP 4-BIT 2-INPT MULTIPLEXER IC:TTL LP HEX INVERTER	12040 12040 01295 01295 12040	DM74L95N DM74L74N SN74298 SN74L98N DM74L04N
A12	03490-66512	1	OUTGUARD REMOTE BOARD ASSY	28480	03490-66512
A12C1 A12C3	0160-0157  0180-0197 	1	C:FXD MICA MY .0047 UF 10% 200VDCW C:FXD ELECT 2.2 UF 10% 20VDCW	28480 56289	0160-0157 1500225X9020A2-DYS
A12MP1 A12MP2 A12MP3	0403-0189 0403-0189 1200-0424		EXTRACTOR:PC, BLACK EXTRACTOR:PC, BLACK SOCKET:IC BLK 14 CONTACT	28480 28480 23880	0403-0189 0403-0189 CSA2900-148
A12R1 A12R2	1810-0049  0683-4715 		RESISTIVE NETWORK:10 X 6.8K OHM 10% R:FXD COMP 470 OHM 5% 1/4W	28480 01121	1810-0049 CB 4715
A12R3 A12R4 A12R5 A12R6, R7	0684-2231 0684-2231 0684-1031 0683-6825		R:FXD COMP 22K OHM 10% 1/4W R:FXD COMP 22K OHM 10% 1/4W R:FXD COMP 10K OHM 10% 1/4W R:FXD COMP 6.8K OHM 5% 1/4W	01121 01121 01121 01121	CB 2231 CB 2231 CB 1031 CB 6825

 Refer to Backdating Sec. VIII

See introduction to this section for ordering information

Table 6-1. Replaceable Parts(Cont'd)

Reference Designation	HP Part Number	Qty	Description	Mfr Code	Mfr Part Number
A1201	1820-0708	2	IC:TTL LOW POWER DUAL 4-INPT MULTIPLEX	07263	U6893L0959X
A1202	1820-0584		IC:TTL 1P QUAD 2-INPT NOR GATE	12040	DM74L02N
A1203	1820-0595		IC:TTL 1P DUAL J-K MASTER SLAVE F/F	12040	DM74L73N
A1204	1820-1053 	1	IC: SCHMITT 14N	01285	SN7414N
A1205	1820-0328	2	IC:TTL QUAD 2-INPT NOR GATE	04713	SN7407N
A13	03490-66513	1	RATIO REFERENCE BOARD ASSY	28480	03490-66513
A13C1	0150-2050		C:FXD CER 1000 PF +R0-20% 100VDCW	56289	C0678102E102ZS26-CDM
A13C2	0150-0093		C:FXD CER 0.01 UF +R0-20% 100VDCW	72982	801-K800011
A13C3	0150-0093		C:FXD CER 0.01 UF +R0-20% 100VDCW	72982	801-K800011
A13C4	0180-0197		C:FXD ELEC 2.2 UF 10% 20VDCW	56289	1500225X9020A2-DYS
A13CR1	1902-0671	2	DIODE BREAKDOWN	28480	1902-0671
A13CR2	1901-0586		DIODE:SI 30 WV 10 PA LEAKAGE	28480	1901-0586
A13CR3	1901-0586		DIODE:SI 30 WV 10 PA LEAKAGE	28480	1901-0586
A13CR4	1902-0671		DIODE BREAKDOWN	28480	1902-0671
A13CR5	1902-3190		DIODE BREAKDOWN:13.0V 5% 400 MW	28480	1902-3190
A13CR6	1902-3190		DIODE BREAKDOWN:13.0V 5% 400 MW	28480	1902-3190
A13CRF	1902-3085	1	DIODE BREAKDOWN:4.75V 5% 400MW	28480	1902-3085
A13MP1	1200-0424	2	SOCKET:INTEGRATED CIRCUIT 14 CONTACT	23880	CSA2900-14B
A13MP2	4040-0748		EXTRACTOR:PC BOARD, BLACK	28480	4040-0748
A13MP3	4040-0754	2	EXTRACTOR:PC BOARD, BLUE	28480	4040-0754
A13MP4	1200-0437		SOCKET:IC 8 PIN	17117	5566-235-5
A13MP5	1200-0437		SOCKET:IC 8 PIN	17117	5566-235-5
A13MP6	1200-0437		SOCKET:IC 8 PIN	17117	5566-235-5
A13MP7	1200-0474		SOCKET:IC 14-PIN	28480	1200-0474
A13R1	0813-0032		R:FXD MW 50K OHM 10% 5W	28480	0813-0032
A13R2	0684-2731	2	R:FXD COMP 27K OHM 10% 1/4W	01121	C8 2731
A13R3	0684-2731		R:FXD COMP 27K OHM 10% 1/4W	01121	C8 2731
A13R4	0698-7962	1	R:FXD FIM 976K OHM 1.0% 1/8W	28480	0698-7962
A13R7	2100-3305	4	R:VAR CERMET 100K OHM 10% 3/4W 1/2 TURN	28480	2100-3305
A13R8	2100-3305		R:VAR CERMET 100K OHM 10% 3/4W 1/2 TURN	28480	2100-3305
A13R9	0698-4202	1	R:FXD FIM 8.87K OHM 1% 1/8W	28480	0698-4202
A13R10	0757-0277	1	R:FXD MET FLM 49.9 OHM 1% 1/8W	28480	0757-0277
A13R11A, R11B	0811-3223	1	R: MATCHED SET	28480	0811-3223
A13R12	2100-3314		R:VAR CERMET 50 OHM 10% TYPE P 3/4W	28480	2100-3314
A13R13	0698-8271	1	R:FXD METAL GLAZE 1.1 OHM 5% 1/4W	28480	0698-8271
A13R14	2100-3313		R:VAR CERMET 100 OHM 10% TYPE P 3/4W	28480	2100-3313
A13R15	0757-0442		R:FXD MET FLM 10.0K OHM 1% 1/8W	28480	0757-0442
A13R16	0757-0378	1	R:FXD MET FLM 11.0 OHM 1% 1/8W	28480	0757-0378
A13R17	2100-3305		R:VAR CERMET 100K OHM 10% 3/4W 1/2 TURN	28480	2100-3305
A13R18	0684-4921	1	R:FXD COMP 4900 OHM 10% 1/4W	01121	C8 3921
A13R19	2100-3305		R:VAR CERMET 100K OHM 10% 3/4W 1/2 TURN	28480	2100-3305
A13U1	1826-0110	3	IC:LINEAR OP. AMPL.	28480	1826-0110
A13U2	1826-0110		IC:LINEAR OP. AMPL.	28480	1826-0110
A13U3	1826-0110		IC:LINEAR OP. AMPL.	28480	1826-0110
A13U4	1820-0223		INTEGRATED CIRCUIT:OPERATIONAL AMPL.	28480	1820-0223
A13U5	1820-0598	2	IC:TTL 1P QUAD 2-INPT EXCL. OR GATE	12040	DM74L86N
A15	03490-60306	1	DATA OUTPUT ISOLATION ASSY	28480	03490-60306
A15MP1	03490-04115	1	PLATE:11 MOUNTING	28480	03490-04115
A15U1-U6	1990-0514	36	OPTISOLATOR-LAMP-PHOTOCHOPPER	32694	DP1 1085

See introduction to this section for ordering information

Table 6-1. Replaceable Parts(Cont'd)

Reference Designation	HP Part Number	Qty	Description	Mfr Code	Mfr Part Number
A15A1 A15A1C1 A15A1C2	03490-66515 1854-0071 1854-0071	1	INWARD RGD ISOLATION BOARD ASSY TSTR:SI NPNISELECTED FROM 2N3704) TSTR:SI NPNISELECTED FROM 2N3704)	28480 28480 28480	03490-66515 1854-0071 1854-0071
A15A1C3 A15A1C4 A15A1C5 A15A1C6	1854-0071 1854-0071 1854-0071 1854-0071		TSTR:SI NPNISELECTED FROM 2N3704) TSTR:SI NPNISELECTED FROM 2N3704) TSTR:SI NPNISELECTED FROM 2N3704) TSTR:SI NPNISELECTED FROM 2N3704)	28480 28480 28480 28480	1854-0071 1854-0071 1854-0071 1854-0071
A15A1K1-R6	0683-1215		R:FXD COMP 120 OHM 5% 1/4W	01121	CB 1215
			R:FXD COMP 47 OHM 10% 1/4W	01121	CB 4701
A15A1K4	8120-1855	4	CABLE:RIBBON	28480	8120-1855
A15A2 A15A2P1 A15A2P2 A15A2P3 A15A2P4	03490-66516 0698-4123 0698-4123 0698-4123 0698-4123	1 12	OUTWARD RGD ISOLATION BOARD ASSY R:FXD MET FLM 499 OHM 1% 1/8W R:FXD MET FLM 499 OHM 1% 1/8W R:FXD MET FLM 499 OHM 1% 1/8W R:FXD MET FLM 499 OHM 1% 1/8W	28480 28480 28480 28480 28480	03490-66516 0698-4123 0698-4123 0698-4123 0698-4123
A15A2P5 A15A2P6	0698-4123 0698-4123		R:FXD MET FLM 499 OHM 1% 1/8W R:FXD MET FLM 499 OHM 1% 1/8W	28480 28480	0698-4123 0698-4123
A15A2K5	8120-1855		CABLE:RIBBON	28480	8120-1855
A17	03490-60308	1	REMOTE ISOLATION ASSY	28480	03490-60308
A17MP1 A17U1-U6	03490-04116 1990-0514	1	PLATE:K MOUNTING OPTISOLATOR-LAMP-PHOTOCHOPPER	28480 32694	03490-04116 OPI 1085
A17A1 A17A1C1 A17A1C2 A17A1C3	03490-66517 1854-0071 1854-0071 1854-0071	1	INWARD RGM ISOLATION BOARD ASSY TSTR:SI NPNISELECTED FROM 2N3704) TSTR:SI NPNISELECTED FROM 2N3704) TSTR:SI NPNISELECTED FROM 2N3704)	28480 28480 28480 28480	03490-66517 1854-0071 1854-0071 1854-0071
A17A1P1 A17A1P2,R3	0698-4123 0683-1215		R:FXD MET FLM 499 OHM 1% 1/8W R:FXD COMP 120 OHM 5% 1/4W	28480 01121	0698-4123 CB 1215
A17A1P4	0698-4123		R:FXD MET FLM 499 OHM 1% 1/8W	28480	0698-4123
A17A1P5 A17A1P6	0698-4123 0683-1215		R:FXD MET FLM 499 OHM 1% 1/8W R:FXD COMP 120 OHM 5% 1/4W	28480 01121	0698-4123 CB 1215
A17A1K6 A17A2	8120-1855 03490-66518	1	CABLE:RIBBON OUTWARD RGM ISOLATION BOARD ASSY	28480 28480	8120-1855 03490-66518
A17A2C1 A17A2C2 A17A2C3	1854-0071 1854-0071 1854-0071		TSTR:SI NPNISELECTED FROM 2N3704) TSTR:SI NPNISELECTED FROM 2N3704) TSTR:SI NPNISELECTED FROM 2N3704)	28480 28480 28480	1854-0071 1854-0071 1854-0071
A17A2P1	0683-1515		R:FXD COMP 150 OHM 5% 1/4W	01121	CB 1515
A17A2P2 A17A2P3 A17A2P4,R5	0698-4123 0698-4123 0683-1215		R:FXD MET FLM 499 OHM 1% 1/8W R:FXD MET FLM 499 OHM 1% 1/8W R:FXD COMP 120 OHM 5% 1/4W	28480 28480 01121	0698-4123 0698-4123 CB 1215
A17A2P6	0698-4123		R:FXD MET FLM 499 OHM 1% 1/8W	28480	0698-4123
A17A2K7	8120-1855		CABLE:RIBBON	28480	8120-1855

See introduction to this section for ordering information

Table 6-1. Replaceable Parts(Cont'd)

Reference Designation	HP Part Number	Qty	Description	Mfr Code	Mfr Part Number
A22	03490-60302	1	SYSTEM ISOLATION ASSY	28480	03490-60302
A22MP1	03490-04114	1	PLATE:SYSTEM LI	28480	J3490-04114
A22U1, U2	1990-0514		OPTISOLATOR-LAMP-PHOTOCHOPPER	32594	OPI 1085
A22A1	03490-66522	1	INGUARD SYSTEM ISOLATION BOARD ASSY	28480	03490-66522
A22A1R1	0684-8221		R:FXD COMP 8200 OHM 10% 1/4W	01121	CR 8221
A22A1K2	0684-1021		R:FXD COMP 1300 OHM 10% 1/4W	01121	CR 1021
A22A1U1	1820-0586		TC:TTL I/P HEX INVERTER	12040	DM74104N
A22A2	03490-66523	1	OUTGUARD SYSTEM ISOLATION BOARD ASSY	28480	03490-66523
A22A2C1	1854-0071		TSTR:SI NPNISELECTED FROM 2N3704	28480	1854-0071
A22A2C2	1854-0071		TSTR:SI NPNISELECTED FROM 2N3704	28480	1854-0071
A22A2R1, R2	0683-1515		R:FXD COMP 150 OHM 5% 1/4W	01121	CR 1515
A24	03490-66524	1	S/H ANALOG JUMPER ASSY	28480	03490-66524
A24MP1	4040-0748		EXTRACTOR:PC BOARD, BLACK	28480	4040-0748
A24MP2	4040-0752	2	EXTRACTOR:PC BOARD, YELLOW	28480	4040-0752
A24R1	0698-0084	1	R:FXD MET FILM 2.15K OHM 1% 1/8W	28480	0698-0084
A25	03490-66525	1	S/H LOGIC JUMPER ASSY	28480	03490-66525
A25MP1	4040-0748		EXTRACTOR:PC BOARD, BLACK	28480	4040-0748
A25MP2	4040-0753	2	EXTRACTOR:PC BOARD, GREEN	28480	4040-0753
A26	03490-66526	1	RATIO JUMPER ASSY	28480	03490-66526
A26MP1	1200-0768		SOCKET:INTEGRATED CIRCUIT 14 CONTACT	91506	314-AG50-3R
A26MP2	4040-0748		EXTRACTOR:PC BOARD, BLACK	28480	4040-0748
A26MP3	4040-0754		EXTRACTOR:PC BOARD, BLUE	28480	4040-0754
A27	03490-66527	1	SAMPLE/HOLD ANALOG BOARD ASSY	28480	03490-66527
A27C1	0160-2198	2	C:FXD MICA 20 PF 5%	72136	RDM15C200J3C
A27C2	0160-2198		C:FXD MICA 20 PF 5%	72136	RDM15C200J3C
A27C5	0180-0197		C:FXD ELECT 2.2 UF 10% 20VDCW	56289	150D225X9020A2-DYS
A27C6	0180-0197		C:FXD ELECT 2.2 UF 10% 20VDCW	56289	150D225X9020A2-DYS
A27C7	0180-0197		C:FXD ELECT 2.2 UF 10% 20VDCW	56289	150D225X9020A2-DYS
A27C8	0180-0197		C:FXD ELECT 2.2 UF 10% 20VDCW	56289	150D225X9020A2-DYS
A27C9	0160-0679	1	C:FXD THERM 5600 PF 5% 100VDCW	28480	0160-0679
A27C10	0160-3855	1	C:FXD POLY 5600 PF 5% 100VDCW	28480	0160-3855
A27C11	0160-3077	2	C:FXD MY 0.027 UF 10% 100VDCW	56289	225P2739WB1-PWM
A27C12	0160-3419	1	C:FXD 0.1 UF 100VDCW	28480	0160-3419
A27C14	0160-2199		C:FXD MICA 30 PF 5% 300VDCW	28480	0160-2199
A27C15	0160-3622		C:FXD CER 0.1 UF +80-20% 100VDCW	72982	8131-100-651-1042
A27C16	0160-3183	2	C:FXD MY 0.47 UF 20% 50VDCW	84411	HF W 101
A27C17	0160-2199		C:FXD MICA 30 PF 5% 300VDCW	28480	0160-2199
A27C18	0160-3183		C:FXD MY 0.47 UF 20% 50VDCW	84411	HF W 101
A27C19	0160-2199		C:FXD MICA 30 PF 5% 300VDCW	28480	0160-2199
A27CR1	1901-0040		DIPD:SILICON 50 MA 30 MV	07263	FOG1088
A27CR2	1901-0040		DIPD:SILICON 50 MA 30 MV	07263	FOG1088

See introduction to this section for ordering information

Table 6-1. Replaceable Parts(Cont'd)

Reference Designation	HP Part Number	Qty	Description	Mfr Code	Mfr Part Number
A27CR3	1901-0376	15	DIODE:SILICON 35V	28480	1901-0376
A27CR4	1901-0376		DIODE:SILICON 35V	28480	1901-0376
A27CR5	1901-0376		DIODE:SILICON 35V	28480	1901-0376
A27CR6	1901-0376		DIODE:SILICON 35V	28480	1901-0376
A27CR7	1901-0040		DIODE:SILICON 50 MA 30 WV	07263	FDG1088
A27CR8	1901-0376	2	DIODE:SILICON 35V	28480	1901-0376
A27CR9	1901-0376		DIODE:SILICON 35V	28480	1901-0376
A27CR10	1901-0376		DIODE:SILICON 35V	28480	1901-0376
A27CR12	1902-3180		DIODE BRFAKDOWN:11.8V 2% 400 MW	28480	1902-3180
A27CR13	1902-3180		DIODE BRFAKDOWN:11.8V 2% 400 MW	28480	1902-3180
A27CR14	1901-0040	4	DIODE:SILICON 50 MA 30 WV	07263	FDG1088
A27CR15	1901-0376		DIODE:SILICON 35V	28480	1901-0376
A27CR16	1901-0376		DIODE:SILICON 35V	28480	1901-0376
A27CR17	1902-3191		DIODE BRFAKDOWN:13.0V 2%	28480	1902-3191
A27CR18	1902-3191		DIODE BRFAKDOWN:13.0V 2%	28480	1902-3191
A27CR19	1901-0376	4	DIODE:SILICON 35V	28480	1901-0376
A27CR20	1901-0376		DIODE:SILICON 35V	28480	1901-0376
A27CR22	1901-0376		DIODE:SILICON 35V	28480	1901-0376
A27CR23	1902-3191		DIODE BRFAKDOWN:13.0V 2%	28480	1902-3191
A27CR24	1902-3191		DIODE BRFAKDOWN:13.0V 2%	28480	1902-3191
A27CR25	1901-0376	4	DIODE:SILICON 35V	28480	1901-0376
A27CR26	1901-0376		DIODE:SILICON 35V	28480	1901-0376
A27CR27	1901-0376		DIODE:SILICON 35V	28480	1901-0376
A27K1	0490-0373	2	RELAY:RFED	28480	0490-0373
A27K2	0490-0373		RELAY:RFED	28480	0490-0373
A27L1	9170-0894		BEAD:SHIELDING	28480	9170-0894
A27L2	9170-0894		BEAD:SHIELDING	28480	9170-0894
A27L3	9170-0894		BEAD:SHIELDING	28480	9170-0894
A27L4	9170-0894	BEAD:SHIELDING	28480	9170-0894	
A27MP1	4040-0748	2	EXTRACTOR:PC BOARD, BLACK	28480	4040-0748
A27MP2	4040-0752		EXTRACTOR:PC BOARD, YELLOW	28480	4040-0752
A27MP3	1200-0437		SOCKET:IC 6 PIN	17117	5566-235-5
A27MP4	1200-0474	2	SOCKET:IC 14-PIN	28480	1200-0474
A27MP5	0340-0060		FEEDTHRU:INSULATED MOUNTING	28480	0340-0060
A27Q1	1855-0093	2	TSTR:FET N-CHANNEL	28480	1855-0093
A27Q2	1855-0308		TSTR:SI NPN DUAL	28480	1855-0308
A27Q3	1855-0093		TSTR:FET N-CHANNEL	28480	1855-0093
A27Q4	1855-0093		TSTR:FET N-CHANNEL	28480	1855-0093
A27Q5	1855-0093		TSTR:FET N-CHANNEL	28480	1855-0093
A27Q6	1855-0308		TSTR:SI NPN DUAL	28480	1855-0308
A27Q7	1855-0093		TSTR:FET N-CHANNEL	28480	1855-0093
A27Q8	1854-0215	1	TSTR:SI NPN	80131	2N3904
A27Q9	1855-0093		TSTR:FET N-CHANNEL	28480	1855-0093
A27Q11	1855-0341		TSTR:SI FET N-CHANNEL	13327	2N4338
A27R1	0757-0280	1	R:FXD MET FLM 1K OHM 1% 1/8W	28480	0757-0280
A27R2	0757-0273		R:FXD MET FLM 3.01K OHM 1% 1/8W	28480	0757-0273
A27R3	2100-2489		R:VAR FLM 5K OHM 10% LIN 1/2W	28480	2100-2489
A27R4	0698-4460		R:FXD FLM 649 OHM 1% 1/8W	28480	0698-4460
A27R5	0698-3445		R:FXD MET FLM 348 OHM 1% 1/8W	28480	0698-3445
A27R6	2100-3103	1	R:VAR CERMET 10K OHM 10% TYPE P 3/4W	28480	2100-3103
A27R8	0757-0449		R:FXD FLM 20K OHM 1% 1/8W	28480	0757-0449
A27R9	0757-0449		R:FXD FLM 20K OHM 1% 1/8W	28480	0757-0449
A27R10	0757-0453		R:FXD MET FLM 30.1K OHM 1% 1/8W	28480	0757-0453
A27R11	0757-0442		R:FXD MET FLM 10.0K OHM 1% 1/8W	28480	0757-0442
A27R13	2100-3306	1	R:VAR CERMET 50K OHM 10% TYPE P 3/4W	28480	2100-3306
A27R14	2100-3311		R:VAR CERMET 500 OHM 10% TYPE P 3/4W	28480	2100-3311
A27R15	0757-0449		R:FXD FLM 20K OHM 1% 1/8W	28480	0757-0449
A27R17	0757-0449		R:FXD FLM 20K OHM 1% 1/8W	28480	0757-0449
A27R18	0684-4731		R:FXD COMP 47K OHM 10% 1/4W	01121	C8 4731
A27R19	0684-4731	4	R:FXD COMP 47K OHM 10% 1/4W	01121	C8 4731
A27R20	0698-4505		R:FXD MET FLM 71.5K OHM 1% 1/8W	28480	0698-4505
A27R21	0698-4505		R:FXD MET FLM 71.5K OHM 1% 1/8W	28480	0698-4505
A27R22	0698-3445		R:FXD MET FLM 348 OHM 1% 1/8W	28480	0698-3445
A27R23	0757-0438		R:FXD MET FLM 5.11K OHM 1% 1/8W	28480	0757-0438
A27R24	0757-0438	4	R:FXD MET FLM 5.11K OHM 1% 1/8W	28480	0757-0438
A27R25	0757-0465		R:FXD MET FLM 100K OHM 1% 1/8W	28480	0757-0465
A27R2E	0757-0449		R:FXD FLM 20K OHM 1% 1/8W	28480	0757-0449
A27R29	0757-0438		R:FXD MET FLM 5.11K OHM 1% 1/8W	28480	0757-0438
A27R30	0757-0465		R:FXD MET FLM 100K OHM 1% 1/8W	28480	0757-0465

See introduction to this section for ordering information

Table 6-1. Replaceable Parts(Cont'd)

Reference Designation	HP Part Number	Qty	Description	Mfr Code	Mfr Part Number
A27R31	0757-0449	2	R:FXD FLM 20K OHM 1% 1/8W	28480	0757-0449
A27R32	0757-0401		R:FXD MFT FLM 100 OHM 1% 1/8W	28480	0757-0401
A27R33	0757-0465		R:FXD MET FLM 100K OHM 1% 1/8W	28480	0757-0465
A27R34	0698-3162		R:FXD MET FLM 46.4K OHM 1% 1/8W	28480	0698-3162
A27R35	0757-0442		R:FXD MET FLM 10.0K OHM 1% 1/8W	28480	0757-0442
A27R36	0757-0401	2	R:FXD MET FLM 100 OHM 1% 1/8W	28480	0757-0401
A27R37	0698-3162		R:FXD MFT FLM 46.4K OHM 1% 1/8W	28480	0698-3162
A27R38	0698-4505		R:FXD MET FLM 71.5K OHM 1% 1/8W	28480	0698-4505
A27R39	0698-4505		R:FXD MFT FLM 71.5K OHM 1% 1/8W	28480	0698-4505
A27R40	0684-4731		R:FXD COMP 47K OHM 10% 1/4W	01121	CB 4731
A27R43	0757-0449	2	R:FXD FLM 20K OHM 1% 1/8W	28480	0757-0449
A27R44	0757-0438		R:FXD MFT FLM 5.11K OHM 1% 1/8W	28480	0757-0438
A27R45	0757-0449		R:FXD FLM 20K OHM 1% 1/8W	28480	0757-0449
A27R46	0757-0449		R:FXD FLM 20K OHM 1% 1/8W	28480	0757-0449
A27R47	0684-4731		R:FXD COMP 47K OHM 10% 1/4W	01121	CB 4731
A27U1	1826-0059	5	IC:LIN. OPERATIONAL AMPLIFIER	12040	LM201AM
A27U2	1826-0018		IC:LINEAR OPERATIONAL AMPLIFIER	28480	1826-0018
A27U3	1826-0059		IC:LIN. OPERATIONAL AMPLIFIER	12040	LM201AM
A27U4	1826-0059	1	IC:LIN. OPERATIONAL AMPLIFIER	12040	LM201AM
A27U5	1826-0021		IC:VOLTAGE FOLLOWER 0 TO 70 C TO-99	12040	LM310H
A27U6	1826-0059		IC:LIN. OPERATIONAL AMPLIFIER	12040	LM201AM
A27U7	1826-0059	2	IC:LIN. OPERATIONAL AMPLIFIER	12040	LM201AM
A27U8	1820-1021		IC:DIGITAL	28480	1820-1021
A27U9	1820-1021	2	IC:DIGITAL	28480	1820-1021
A27U10	1820-0174		IC:TTL HEX INVERTER	01295	SN74J4N
A28	03490-66528	1	SAMPLE/HOLD LOGIC BOARD ASSY	28480	03490-66528
A28C1	0160-3077	1	C:FXD HY 0.022 UF 10% 100VDCW	56289	225P2739WBI-PWH
A28C2	0150-0084		C:FXD CER 0.1 UF +80-20% 100VDCW	72982	8131-100-651-1042
A28C3	0160-2605		C:FXD CER 0.02 MFD +80-20% 25VDCW	72982	5835000-V5U 203Z
A28CR1	1901-0518	1	DIONESHOT CARRIER	28480	1901-0518
A28CR2	1902-3183		DIOFF:BRFAKDOWN 12.1V 2% 400MH	28480	1902-3183
A28MP1	4040-0748	4	EXTRACTOR:PC BOARD, BLACK	28480	4040-0748
A28MP2	4040-0753		EXTRACTOR:PC BOARD, GREEN	28480	4040-0753
A28MP3	1200-0474		SOCKET:IC 14-PIN	28480	1200-0474
A28MP4	1200-0473		SOCKET:IC 16-PIN	28480	1200-0473
A28MP5	1200-0469	4	SOCKET:IC 28 CONTACT DUAL-INLINE TYPE	28480	1200-0469
A28MP6	0380-0832		STANDOFF:SWAGE TYPE 0.500" LG	00000	080
A28Q1	1854-0071	1	TSTR:SI NPNSELECTED FROM 2N3704I	28480	1854-0071
A28R1	0684-1031	3	R:FXD COMP 10K OHM 10% 1/4W	01121	CB 1031
A28R2	0684-3321		R:FXD COMP 3300 OHM 10% 1/4W	01121	CB 3321
A28R3	0684-5621		R:FXD COMP 5.6K OHM 10% 1/4W	01121	CB 5621
A28R4	0684-6821		R:FXD COMP 6.8K OHM 10% 1/4W	01121	CB 6821
A28R5	0684-1011		R:FXD COMP 100 OHM 10% 1/4W	01121	CB 1011
A28R6	0684-3321		R:FXD COMP 3300 OHM 10% 1/4W	01121	CB 3321
A28R7	0684-1031		R:FXD COMP 10K OHM 10% 1/4W	01121	CB 1031
A28R8	0684-5621		R:FXD COMP 5.6K OHM 10% 1/4W	01121	CB 5621
A28R9	1810-0050		RESISTIVE NETWORK 10 X 15K OHM 10%	28480	1810-0050
A28R10	1810-0050		RESISTIVE NETWORK 10 X 15K OHM 10%	28480	1810-0050
A28R11	0684-5621		R:FXD COMP 5.6K OHM 10% 1/4W	01121	CB 5621
A28R12	0684-5621		R:FXD COMP 5.6K OHM 10% 1/4W	01121	CB 5621
A28R13	0757-0446		R:FXD MFT FLM 15.0K OHM 1% 1/8W	28480	0757-0446
A28R14	0757-0283		R:FXD MET FLM 2.00K OHM 1% 1/8W	28480	0757-0283
A28R15	0684-1021		R:FXD COMP 1000 OHM 10% 1/4W	01121	CB 1021
A28U1	1820-0583	2	IC:TTL LP QUAD 2-INPT NAND GATE	12040	DM74L00N
A28U2	1820-0658		IC:TTL LOW POWER 8-INPUT MULTIPLEXER	07263	SL17146
A28U3	1820-0596		IC:TTL LP DUAL EDGE TRIG. D F/F	12040	DM74L74N
A28U3	1820-0658	1	IC:TTL LOW POWER 8-INPUT MULTIPLEXER	07263	SL17146
A28U4	1820-0656		IC:TTL LP 4-BIT 2-INPT MULTIPLEXER	01295	SN74L98N
A28U5	1820-0656		IC:TTL LP 4-BIT 2-INPT MULTIPLEXER	01295	SN74L98N
A28U6	1820-0708		IC:TTL LOW POWER DUAL 4-INPT MULTIPLEX	07263	U6893L 0959X
A28U7	1820-0471		IC:TTL HEX INVERTER W/OPEN COLL.(30V)	01295	SN7406N

See introduction to this section for ordering information

Table 6-1. Replaceable Parts(Cont'd)

Reference Designation	HP Part Number	Qty	Description	Mfr Code	Mfr Part Number
A28U9	1820-0099		IC:TTL 4-BIT BINARY COUNTER	01295	SN7493N
A28U1C	1820-0656		IC:TTL LP 4-BIT 2-INPT MULTIPLEXER	01295	SN74198N
A28U11	1820-0980	1	IC:DIGITAL CMOS HEX BUFFER/TRANSLATOR	28480	1820-0980
A28U12	1820-0598		IC:TTL LP QUAD 2-INPT EXCL. OR GATE	12040	DM74L86N
A28U13	1820-0077		IC:TTL DUAL D F/F	01295	SN7474N
A28U14	1818-2094	1	IC:N-CHANNEL RDM	28480	1818-2094
A28U15	1820-0656		IC:TTL LP 4-BIT 2-INPT MULTIPLEXER	01295	SN74198N
A28U16	1820-0935	1	IC:DIGITAL CMOS 14-BIT BINARY COUNTER	28480	1820-0935
A29	11118-66501	1	OUTGUARD TRIGGER ASSY	28480	11118-66501
A29C1	0180-0650		C:FXD AL ELFCT 390MF 20VDCW	28480	0180-0650
A29C3	0180-0228	1	C:FXD ELECT 22 UF 10% 15VDCW	56289	1500226X901582-DYS
A29C4	0150-0050		C:FXD CER 1000 PF +80-20% 1000VDCW	56289	C0678102F1022526-COH
A29C5	0170-0040		C:FXD MY 0.047 UF 10% 200VDCW	56289	142P47392-PTS
A29C6	0150-0050		C:FXD CER 1000 PF +80-20% 1000VDCW	56289	C0678102E1022526-COH
A29CR1	1901-0028		DIODE:SILICON 0.75A 400PIV	04713	SR1358-9
A29CR2	1907-0049		DIODE:BRFAKDOWN 6.19V 5%	04713	S210939-122
A29CR3	1901-0040		DIODE:SILICON 50 MA 30 WV	07263	FDG1088
A29MP1	1251-2551		CONNECTOR:SINGLE CONTACT MINIATURE	00779	332070
A29Q1	1854-0077	1	TSTR:SI NPN	07263	S17843
A29Q2	1854-0071		TSTR:SI NPN(SELECTED FROM 2N3704)	28480	1854-0071
A29Q3	1854-0071		TSTR:SI NPN(SELECTED FROM 2N3704)	28480	1854-0071
A29R1	0684-1031		R:FXD COMP 10K OHM 10% 1/4W	01121	CR 1031
A29R2	0757-0388		R:FXD FLM 30.1 OHM 10% 1/8W	28480	0757-0388
A29R3	0684-8221		R:FXD COMP 8200 OHM 10% 1/4W	01121	CR 8221
A29R4	0684-1011		R:FXD COMP 100 OHM 10% 1/4W	01121	CR 1011
A29R5	0684-1231		R:FXD COMP 12K OHM 10% 1/4W	01121	CR 1231
A29K6	0684-2231		R:FXD COMP 22K OHM 10% 1/4W	01121	CR 2231
A29R7	0684-1021		R:FXD COMP 1000 OHM 10% 1/4W	01121	CR 1021
A29R8	0684-1021		R:FXD COMP 1000 OHM 10% 1/4W	01121	CR 1021
A29R9	0684-8221		R:FXD COMP 8200 OHM 10% 1/4W	01121	CR 8221
A29T1	9100-3273	2	TRANSFORMER:PULSE	28480	9100-3273
A29U1	1820-0586		IC:TTL LP HEX INVERTER	12040	DM74104N
A29W6	03490-61617	1	CABLE ASSY:TRIG	28480	03490-61617
A30/A35	03490-69509	1	HP-IB ISOLATION ASSY: INCLUDES A30, A35 AND U1 THRU U11	28480	03490-69509
A30/A35U1-U11	1990-0514		OPTISOLATOR-LAMP-PHOTOCHOPPER	32684	OPI 1085
A30	03490-66530	1	HP-IB OUTGUARD ISOLATION ASSY	28480	03490-66530
A30C1	0180-1701		C:FXD ELFCT 6.8 UF 20% 6VDCW	28480	0180-1701
A30C2	0160-0156	1	C:FXD MY 0.0039 UF 10% 200VDCW	56289	142P39292-PTS
A30C3	0150-0093		C:FXD CER 0.01 UF +80-20% 100VDCW	72982	801-KR00011
A30C4	0150-0093		C:FXD CER 0.01 UF +80-20% 100VDCW	72982	801-KR00011
A30CR1	1901-0040		DIODE:SILICON 50 MA 30 WV	07263	FDG1088
A30CR2	1907-0040	2	DIODE BREAKDOWN:3.01V 5% 400 MW	28480	1902-3030
A30CR3	1901-0040		DIODE:SILICON 50 MA 30 WV	07263	FDG1088
A30MP1	1200-0431		SOCKET:IC 24 CONTACT	28480	1200-0431
A30MP2	1200-0473		SOCKET:IC 16-PIN	28480	1200-0473
A30MP3	1200-0474		SOCKET:IC 14-PIN	28480	1200-0474
A30Q1	1854-0071		TSTR:SI NPN(SELECTED FROM 2N3704)	28480	1854-0071
A30Q2	1854-0071		TSTR:SI NPN(SELECTED FROM 2N3704)	28480	1854-0071
A30Q3	1854-0071		TSTR:SI NPN(SELECTED FROM 2N3704)	28480	1854-0071
A30Q4	1854-0071		TSTR:SI NPN(SELECTED FROM 2N3704)	28480	1854-0071
A30Q5	1854-0071		TSTR:SI NPN(SELECTED FROM 2N3704)	28480	1854-0071
A30Q6	1854-0071		TSTR:SI NPN(SELECTED FROM 2N3704)	28480	1854-0071
A30Q7	1854-0071		TSTR:SI NPN(SELECTED FROM 2N3704)	28480	1854-0071
A30Q8	1854-0071		TSTR:SI NPN(SELECTED FROM 2N3704)	28480	1854-0071
A30Q9	1854-0071		TSTR:SI NPN(SELECTED FROM 2N3704)	28480	1854-0071
A30R1	0683-1025		R:FXD COMP 1000 OHM 5% 1/4W	01121	CR 1025
A30R2	0684-3331		R:FXD COMP 33K OHM 10% 1/4W	01121	CR 3331

See introduction to this section for ordering information

Table 6-1. Replaceable Parts(Cont'd)

Reference Designation	HP Part Number	Qty	Description	Mfr Code	Mfr Part Number
A30R3	0684-6821	1	R:FXD COMP 6.8K OHM 10% 1/4W	01121	CB 6821
A30R4	0684-3331		R:FXD COMP 33K OHM 10% 1/4W	01121	CB 3331
A30R5	0684-3331		R:FXD COMP 33K OHM 10% 1/4W	01121	CR 3331
A30R6	0684-5611		R:FXD COMP 560 OHM 10% 1/4W	01121	CR 5611
A30R12	0684-6821		R:FXD COMP 6.8K OHM 10% 1/4W	01121	CB 6821
A30R13	0684-6821	11	R:FXD COMP 6.8K OHM 10% 1/4W	01121	CB 6821
A30R14	0684-6821		R:FXD COMP 6.8K OHM 10% 1/4W	01121	CR 6821
A30R15	0684-6821		R:FXD COMP 6.8K OHM 10% 1/4W	01121	CB 6821
A30R16	0684-6821		R:FXD COMP 6.8K OHM 10% 1/4W	01121	CB 6821
A30R17-R21	0883-1515		R:FXD COMP 150 OHM 5% 1/4W	01121	CB 1515
A30R22	0684-1031	11	R:FXD COMP 10K OHM 10% 1/4W	01121	CB 1031
A30R23	0684-1031		R:FXD COMP 10K OHM 10% 1/4W	01121	CR 1031
A30R24 -R28	0683-1025		R:FXD COMP 1K OHM 5% 1/4W	01121	CB 1025
A30R25	0684-1521	1	R:FXD COMP 1500 OHM 10% 1/4W	01121	CB 1521
A30R30	0684-6821		R:FXD COMP 6.8K OHM 10% 1/4W	01121	CR 6821
	0883-1515		R:FXD COMP 150 OHM 5% 1/4W	01121	CB 1515
A30U1	1820-0710	3	IC:DIGITAL TTL+LOGIC 5V 5X	07263	SL17315
A30U2	1820-0621		IC:TTL QUAD 2-INPT NAND BUFFER W/OPEN C	01295	SN7438N
A30U3	1820-0586		IC:TTL LP HEX INVERTER	12040	DM74L04N
A30U4	1820-0640		IC:TTL DATA SELECTOR/MULTIPLEXER	01295	SN74150N
A30U5	1820-0174		IC:TTL LP HEX INVERTER	01295	SN7404N
A30U6	1820-0590	1	IC:TTL LP DUAL 2W 3-STATE IN AND-OR INV	12040	DM74L51N
A30U7	1820-0710		IC:DIGITAL TTL+LOGIC 5V 5X	07263	SL17315
A30U8	1820-0586		IC:TTL LP HEX INVERTER	12040	DM74L04N
A31	03490-66531	1	OUTGUARD MOTHER BOARD ASSY	28480	03490-66531
A31C1, C2	0180-0650	1	C:FXD AL FLECT 390 UF 10VDCW	28480	0180-0650
A31C3	0180-0197		C:FXD FLECT 2.2 UF 10% 20VDCW	56289	1500225X9020A2-DYS
A31C4	0180-0229		C:FXD FLECT 33 UF 10% 10VDCW	28480	0180-0229
A31C5	0150-0050		C:FXD CER 1000 PF +80-20% 1000VDCW	56289	C067R102F102ZS26-CDH
A31C6	0180-0197		C:FXD FLECT 2.2 UF 10% 20VDCW	56289	1500225X9020A2-DYS
A31C7	0150-0050		C:FXD CER 1000 PF +80-20% 1000VDCW	56289	C067R102F102ZS26-CDH
A31C8	0170-0040		C:FXD MY 0.047 UF 10% 200VDCW	56289	192P47397-PTS
A31C9	0150-0050		C:FXD CER 1000 PF +80-20% 1000VDCW	56289	C067R102F102ZS26-CDH
A31C10	0150-0093		C:FXD CER 0.01 UF +80-20% 100VDCW	72982	R01-K800311
A31CR1	1901-0363		1	DIODE ASSY:ST 100 PIV PER CELL	28480
A31CR2	1901-0363	DIODE ASSY:ST 100 PIV PER CELL		28480	1901-0363
A31CR3	1901-0040	DIODE:SILICON 50 MA 30 WV		07263	FDG1388
A31CR4	1901-0040	DIODE:SILICON 50 MA 30 WV		07263	FDG1388
A31CR5	1902-3190	1	DIODE BRFKARDIWN:13.0V 5% 400 MW	28480	1902-3190
A31CR6	1901-0040		DIODE:SILICON 50 MA 30 WV	07263	FDG1388
A31J1	1251-1365	1	CONN:PC 44 (2X22) CONTACTS	71785	252-22-30-300

See introduction to this section for ordering information

Refer to Backdating Sec. VIII

Table 6-1. Replaceable Parts(Cont'd)

Reference Designation	HP Part Number	Qty	Description	Mfr Code	Mfr Part Number
A31J2	1251-1365		CONN:PC 44 (2X22) CONTACTS	71785	252-22-30-300
A31J3	1251-1365		CONN:PC 44 (2X22) CONTACTS	71785	252-22-30-300
A31MP1	1205-0259	1	HEAT DISSIPATOR:FOR T0-3 CASE	13173	6104C-T0P
A31MP2	1251-0615	1	CONNECTOR:14-PIN, DUAL-IN-LINE	28489	1251-0615
A31MP3	1200-0474		SOCKET:IC 14-PIN	28480	1200-0474
A31MP4	0380-0643	1	STANDOFF:STUD MOUNT	28480	0380-0643
A31MP5	1251-2551		CONNECTOR:SINGLE CONTACT MINIATURE	30779	337071
A31MP6	2260-0001	2	NUT:HEX SST 4-40X1/4X3/32	80120	080#
A31MP7	5040-0170		GUIDE:PLUG-IN PC BOARD	28480	5040-0170
A31Q1	1854-0071		TSTR:SI NPN(SELECTED FROM 2N3704)	28480	1854-0071
A31Q2	1854-0071		TSTR:SI NPN(SELECTED FROM 2N3704)	28480	1854-0071
A31R3	0684-3321		R:FXD COMP 3300 OHM 10% 1/4W	01121	CR 3321
A31R4	0684-1011		R:FXD COMP 100 OHM 10% 1/4W	01121	CR 1011
A31R5	0684-8221		R:FXD COMP 8200 OHM 10% 1/4W	01121	CR 8221
A31R6	1810-0135	1	RESISTIVE NETWORK 5 X 10K OHM 5% 1/4W	28480	1810-0135
A31R7	1810-0136	2	RESISTIVE NETWORK:	28480	1810-0136
A31R8	1810-0136		RESISTIVE NETWORK:	28480	1810-0136
A31R9	0684-6821		R:FXD COMP 6.8K OHM 10% 1/4W	01121	CR 6821
A31R10	0684-2231		R:FXD COMP 22K OHM 10% 1/4W	01121	CR 2231
A31R11	0684-1231		R:FXD COMP 12K OHM 10% 1/4W	01121	CR 1231
A31R12	0684-1021		R:FXD COMP 1000 OHM 10% 1/4W	01121	CR 1021
A31R13	0684-8221		R:FXD COMP 8200 OHM 10% 1/4W	01121	CR 8221
A31R14	0684-1021		R:FXD COMP 1000 OHM 10% 1/4W	01121	CR 1021
A31R15	0684-2221		R:FXD COMP 2200 OHM 10% 1/4W	01121	CR 2221
A31T1	9100-3273		TRANSFORMER:PULSE	28480	9100-3273
A31U1	1820-0430		IC:LINEAR, VOLTAGE REGULATOR 5V	28480	1820-0430
A31U2	1820-0174		IC:TTL HEX INVERTER	01295	SN7404N
A31U3	1820-0621		IC:TTL QUAD 2-INPT(NAND) BUFFER W/OPEN C	01295	SN7438N
A31U4	1820-0586		IC:TTL 1P HEX INVERTER	12040	DM74L04N
A31W6	03490-61617	1	CABLE ASSY:TRIG	28480	03490-61617
A31W7	03490-61618	1	CABLE ASSY:ASCD	28480	03490-61618
A32	03490-66532	1	OUTGHARD KIM ASSY	28480	03490-66532
A32C1	0160-0299	1	C:FXD MY 1800 PF 10% 250VDCW	56289	192P18292-PTS
A32C2	0180-1743	1	C:FXD FLECT 0.1 UF 10% 35VDCW	56289	150H104X5035A2-NYS
A32C3	0160-1867	1	C:FXD CFR 0.01 UF +10J-10% 25VDCW	72982	8005-01ACR-W5K-103P
A32C4	0150-0093	1	C:FXD CFR 0.01 UF +80-20% 100VDCW	72982	R01-KR03011
A32CR1	1901-0040		DIODE:SILICON 50 MA 30 WV	07263	FDG1088
A32CR2	1901-0040		DIODE:SILICON 50 MA 30 WV	07263	FDG1088
A32MP1	4040-0713	1	EXTRACTOR:PC BOARD, ORANGE	28480	4040-0713
A32MP2	1200-0431		SOCKET:IC 24 CONTACT	28480	1200-0431
A32MP3	1200-0469		SOCKET:IC 28 CONTACT DUAL-IN-LINE TYPE	28480	1200-0469
A32MP4	1200-0473		SOCKET:IC 16-PIN	28480	1200-0473
A32MP5	1200-0474		SOCKET:IC 14-PIN	28480	1200-0474
A32R1	0684-1231		R:FXD COMP 12K OHM 10% 1/4W	01121	CR 1231
A32R2	0684-2221		R:FXD COMP 2200 OHM 10% 1/4W	01121	CR 2221
A32R3	1810-0050		RESISTIVE NETWORK 10 X 15K OHM 10%	28480	1810-0050
A32R4	1810-0055	3	RESISTIVE NETWORK:8 ALL 10K OHM 5%	28480	1810-0055
A32R5	1810-0055		RESISTIVE NETWORK:8 ALL 10K OHM 5%	28480	1810-0055
A32R6	0684-1031		R:FXD COMP 10K OHM 10% 1/4W	01121	CR 1031
A32R7	0684-1031		R:FXD COMP 10K OHM 10% 1/4W	01121	CR 1031
A32R8	0684-1031		R:FXD COMP 10K OHM 10% 1/4W	01121	CR 1031
A32R9	0684-1031		R:FXD COMP 10K OHM 10% 1/4W	01121	CR 1031
A32R10	0684-1031		R:FXD COMP 10K OHM 10% 1/4W	01121	CR 1031
A32R11	0684-1031		R:FXD COMP 10K OHM 10% 1/4W	01121	CR 1031
A32R12	0684-1031		R:FXD COMP 10K OHM 10% 1/4W	01121	CR 1031
A32U1	1820-0567		IC:TTL DUAL VOLTAGE-CONTROLLED MULTIVI	04713	MC4024P
A32U2	1818-2097	1	ROM:N-CHANNEL	28480	1818-2097
A32U3	1818-2098	1	ROM:N-CHANNEL	28480	1818-2098
A32U4	1820-0788		IC:TTL HEX D-TYPE FLIP/FLOP WITH CLEAR	01295	SN35431
A32U5	1820-0586		IC:TTL 1P HEX INVERTER	12040	DM74L04N
A32U6	1820-0788		IC:TTL HEX D-TYPE FLIP/FLOP WITH CLEAR	01295	SN35431

See introduction to this section for ordering information

Table 6-1. Replaceable Parts(Cont'd)

Reference Designation	HP Part Number	Qty	Description	Mfr Code	Mfr Part Number
A33	03490-66533	1	OUTWARD DATA ASSY	28480	03490-66533
A33C1	0150-0050		C:FXD CER 1000 PF +80-20% 1000VDCW	56289	C0678102E102Z526-CDH
A33C2	0150-0093		G:FXD CFR 0.01 UF +80-20% 100VDCW	72982	801-K800011
A33C3	0150-0093		C:FXD CFR 0.01 UF +80-20% 100VDCW	72982	801-K800011
A33CR1	1902-3030		DIODE BRFAKDOWN:3.01V 5% 400 MW	28480	1902-3030
A33MP1	0403-0186	1	EXTRACTOR:PC BOARD, VIOLET	28480	0403-0186
A33MP2	1200-0431		SOCKET:IC 24 CONTACT	28480	1200-0431
A33MP3	1200-0473		SOCKET:IC 16-PIN	28480	1200-0473
A33MP4	1200-0474		SOCKET:IC 14-PIN	28480	1200-0474
A33R1	0684-4721		R:FXD COMP 4700 OHM 10% 1/4W	01121	CR 4721
A33R2	0684-2721		R:FXD COMP 2700 OHM 10% 1/4W	01121	CR 2721
A33U1	1820-0640		IC:TTL DATA SELECTOR/MULTIPL EXFR	01295	SN74150N
A33U2	1820-0627		IC:TTL LP ACD TO DEC. DECODER	07263	U7893L0159X
A33U3	1820-0627		IC:TTL LP ACD TO DEC. DECODER	07263	U7893L0159X
A33U4	1820-0596		IC:TTL LP DUAL EDGE TRIG. D F/F	12040	DM74L74N
A33U5	1820-0596		IC:TTL LP DUAL EDGE TRIG. D F/F	12040	DM74L74N
A33U6	1820-0596		IC:TTL LP DUAL EDGE TRIG. D F/F	12040	DM74L74N
A33U7	1820-0591		IC:TTL LP 4W 3-2-2-3 INPT.AND OR GATE	12040	DM74L54N
A33U8	1820-0839	3	IC:TTL QUAD D-TYPE F/F	01295	SN74175N
A33U9	1820-0839		IC:TTL QUAD D-TYPE F/F	01295	SN74175N
A33U1C	1820-0583		IC:TTL LP QUAD 2-INPT NAND GATE	12040	DM74L00N
A33U11	1820-0174		IC:TTL HEX INVERTER	01295	SN7404N
A33U12	1820-0621		IC:TTL QUAD 2-INPT NAND BUFFER W/OPEN C	01295	SN7438N
A33U13	1820-0591		IC:TTL LP 4W 3-2-2-3 INPT.AND OR GATE	12040	DM74L54N
A33U14	1820-0596		IC:TTL LP DUAL EDGE TRIG. D F/F	12040	DM74L74N
A34	03490-66534	1	INWARD ROM ASSY	28480	03490-66534
A34C1	0150-0093		C:FXD CFR 0.01 UF +80-20% 100VDCW	72982	801-K800011
A34CR1	1902-3190		DIODE BRFAKDOWN:13.0V 5% 400 MW	28480	1902-3190
A34MP1	4040-0748		EXTRACTOR:PC BOARD, BLACK	28480	4040-0748
A34MP2	4040-0747		EXTRACTOR:PC BOARD, GRAY	28480	4040-0747
A34MP3	1200-0469		SOCKET:IC 28 CONTACT DUAL-INLINE TYPE	28480	1200-0469
A34MP4	1200-0473		SOCKET:IC 16-PIN	28480	1200-0473
A34MP5	1200-0474		SOCKET:IC 14-PIN	28480	1200-0474
A34R1	0684-2221		R:FXD COMP 220J OHM 10% 1/4W	01121	CR 2221
A34R2	0684-3321		R:FXD COMP 330J OHM 10% 1/4W	01121	CR 3321
A34R3	0684-1531		R:FXD COMP 15K OHM 10% 1/4W	01121	CR 1531
A34R4	1810-0055		R:RESISTIVE NETWORK:28 ALL 10K OHM 5%	28480	1810-0055
A34R5	0684-1831	8	R:FXD COMP 18K OHM 10% 1/4W	01121	CR 1831
A34R6	0684-1831		R:FXD COMP 18K OHM 10% 1/4W	01121	CR 1831
A34R7	0684-1031		R:FXD COMP 10K OHM 10% 1/4W	01121	CR 1031
A34R8	0684-1031		R:FXD COMP 10K OHM 10% 1/4W	01121	CR 1031
A34R9	0684-1031		R:FXD COMP 10K OHM 10% 1/4W	01121	CR 1031
A34R1C	0684-1031		R:FXD COMP 10K OHM 10% 1/4W	01121	CR 1031
A34R11	0684-1831		R:FXD COMP 18K OHM 10% 1/4W	01121	CR 1831
A34R12	0684-1031		R:FXD COMP 10K OHM 10% 1/4W	01121	CR 1031
A34R13	0684-1031		R:FXD COMP 10K OHM 10% 1/4W	01121	CR 1031
A34R14	0684-1031		R:FXD COMP 10K OHM 10% 1/4W	01121	CR 1031
A34R15	0684-1831		R:FXD COMP 18K OHM 10% 1/4W	01121	CR 1831
A34R16	0684-1031		R:FXD COMP 10K OHM 10% 1/4W	01121	CR 1031
A34R17	0684-1831		R:FXD COMP 18K OHM 10% 1/4W	01121	CR 1831
A34R18	0684-1031		R:FXD COMP 10K OHM 10% 1/4W	01121	CR 1031
A34R19	0684-1031		R:FXD COMP 10K OHM 10% 1/4W	01121	CR 1031
A34R20	0684-1031		R:FXD COMP 10K OHM 10% 1/4W	01121	CR 1031
A34R21	0684-1831		R:FXD COMP 18K OHM 10% 1/4W	01121	CR 1831
A34R22	0684-1831		R:FXD COMP 18K OHM 10% 1/4W	01121	CR 1831
A34R23	0684-1831		R:FXD COMP 18K OHM 10% 1/4W	01121	CR 1831
A34R24	0684-1031		R:FXD COMP 10K OHM 10% 1/4W	01121	CR 1031

See introduction to this section for ordering information

Table 6-1. Replaceable Parts(Cont'd)

Reference Designation	HP Part Number	Qty	Description	Mfr Code	Mfr Part Number
A3403	1820-0596	2	IC:TTL LP DUAL EDGE TRIG. D F/F	12340	DM74L74N
A3404	1820-0777	1	IC:TTL LCM POWER BCD TO DECODER	28480	1820-0777
A3405	1818-2096	1	COMMON-CHANNEL	28480	1818-2096
A3406	1820-0620	2	IC:TTL DUAL 4-INPT MULTIPLEXER	01295	SN74153N
A3407	1820-0620		IC:TTL DUAL 4-INPT MULTIPLEXER	01295	SN74153N
A3408	1820-0596		IC:TTL LP DUAL EDGE TRIG. D F/F	12340	DM74L74N
A3409	1820-0788		IC:TTL HEX D-TYPE F/IF/FLOP WITH CLEAR	01295	SN35431
A34010	1820-0328		IC:TTL QUAD 2-INPT NDR GATE	04713	SN7402N
A34W1	03490-61619	2	CABLE ASSY	28480	03490-61619
A30/A35	03490-69509		HP-IB ISOLATION ASSY: INCLUDES A30, A35, AND U1-U11	28480	03490-69509
A30/A35U1-11	1990-0402		TSTR:PHOTO	28480	1990-0402
A35	03490-66535	1	HP-IB INGUARD ISOLATION BOARD ASSY	28480	03490-66535
A35C1	0150-0093		C:FXD CER 0.01 UF +80-20% 100VDCW	72982	801-KR00011
A35MP1	1200-0473		SOCKET:IC 16-PIN	28480	1200-0473
A35MP2	1200-0474		SOCKET:IC 14-PIN	28480	1200-0474
A3501	1854-0071		TSTR:SI NPN(SELECTED FROM 2N3704)	28480	1854-0071
A3502	1854-0071		TSTR:SI NPN(SELECTED FROM 2N3704)	28480	1854-0071
A3503	1854-0071		TSTR:SI NPN(SELECTED FROM 2N3704)	28480	1854-0071
A3504	1854-0071		TSTR:SI NPN(SELECTED FROM 2N3704)	28480	1854-0071
A3505	1854-0071		TSTR:SI NPN(SELECTED FROM 2N3704)	28480	1854-0071
A35R1, R5	0683-1025		R:FXD COMP 1K OHM 5% 1/4W	01121	CB 1025
A35R6	0684-6721		R:FXD COMP 1500 OHM 10% 1/4W	01121	CB 1521
A35R7	0684-6821		R:FXD COMP 4700 OHM 10% 1/4W	01121	CB 4721
A35R8	0684-6821		R:FXD COMP 6.8K OHM 10% 1/4W	01121	CB 6821
A35R9	0684-6821		R:FXD COMP 6.8K OHM 10% 1/4W	01121	CB 6821
A35R10	0684-6821		R:FXD COMP 6.8K OHM 10% 1/4W	01121	CB 6821
A35R11	0684-6821		R:FXD COMP 6.8K OHM 10% 1/4W	01121	CB 6821
A35R12-R16	0683-1515		R:FXD COMP 150 OHM 5% 1/4W	01121	CB 1515
A35R17	0683-1025		R:FXD COMP 1000 OHM 5% 1/4W	01121	CB 1025
A3501	1820-0174		IC:TTL HEX INVERTER	01295	SN7406N
A3502	1820-0876	1	IC:DIGITAL LP QUAD 4-BIT, TTL	01295	SN74L75N
A3503	1820-0586		IC:TTL LP HEX INVERTER	12040	DM74L06N
A3504	1820-0513	1	IC:TTL QUAD 2-INPT AND GATE(OPEN COL)	01295	SN7409N
A35W1	03490-61619		CABLE ASSY	28480	03490-61619
A36	03490-66536	1	INGUARD PROGRAM ASSY	28480	03490-66536
A36C1	0150-0093		C:FXD CER 0.01 UF +80-20% 100VDCW	72982	801-KR00011
A36MP1	4040-0748		EXTRACTOR:PC BOARD, BLACK	28480	4040-0748
A36MP2	4040-0755		EXTRACTOR:PC BOARD, VIOLET	28480	4040-0755
A36MP3	1200-0431		SOCKET:IC 24 CONTACT	28480	1200-0431
A36MP4	1200-0473		SOCKET:IC 16-PIN	28480	1200-0473

3. Refer to Backdating Sec. VIII

See introduction to this section for ordering information

Table 6-1. Replaceable Parts(Cont'd)

Reference Designation	HP Part Number	Qty	Description	Mfr Code	Mfr Part Number
A36MP5	1200-0474		SOCKET: IC 14-PIN	28480	1200-0474
A36Q1	1854-0071		TSTR:SI NPN(SELECTED FROM 2N3704)	28480	1854-0071
A36R1	0684-4701		R:FXD COMP 47 OHM 10% 1/4W	01121	CB 4701
A36R2	0684-1811		R:FXD COMP 180 OHM 10% 1/4W	01121	CB 1811
A36R3	0684-1031		R:FXD COMP 10K OHM 10% 1/4W	01121	CB 1031
A36R4	0684-1031		R:FXD COMP 10K OHM 10% 1/4W	01121	CB 1031
A36U1	1820-0600	1	IC:TTL LP DECADE COUNTER	12040	DM85L90N
A36U2	1820-0777		IC:TTL LOW POWER BCD TO DECODER	28480	1820-0777
A36U3	1820-0511		IC:TTL QUAD 2-INPT AND GATE	01295	SN7408N
A36U4	1820-0839		IC:TTL QUAD D-TYPE F/F	01295	SN74175N
A36U5	1820-0174		IC:TTL HEX INVERTER	01295	SN7404N
A36U6	1820-0656		IC:TTL LP 4-BIT 2-INPT MULTIPLEXER	01295	SN74L98N
A36U7	1820-0640		IC:TTL DATA SELECTOR/MULTIPL FXER	01295	SN74150N
A36U8	1820-0656		IC:TTL LP 4-BIT 2-INPT MULTIPLEXER	01295	SN74L98N
A36U9	1820-0596		IC:TTL LP DUAL EDGE TRIG. D F/F	12040	DM74L74N
A36U11	1820-0596		IC:TTL LP DUAL EDGE TRIG. D F/F	12040	DM74L74N
A36U12	1820-0596		IC:TTL LP DUAL EDGE TRIG. D F/F	12040	DM74L74N
A37	11118-66502	1	SAMPLE/HOLD TRIGGER GATE ASSY	28480	11118-66502
A37MP1	4040-0748		EXTRACTOR: PC BOARD BLACK	28480	4040-0748
A37MP2	4040-0755		EXTRACTOR: PC BOARD V10	28480	4040-0755
A37U1	1820-0583		IC: TTL LP QUAD 2-INPUT NAND GATE	12040	DM74L00N

See introduction to this section for ordering information

Table 6-1. Replaceable Parts(Cont'd)

Reference Designation	HP Part Number	Qty	Description	Mfr Code	Mfr Part Number
CHASSIS & MISCELLANEOUS PARTS					
A1	03490-66501		MAIN CIRCUIT BOARD ASSY	28480	03490-66501
A2	03490-66502		HIGH IMPEDANCE ASSY	28480	03490-66502
A3	03490-66543		BOARD ASSY:DISPLAY	28480	03490-66543
A4	03490-66504		BOARD ASSY:REMOTE JUMPER	28480	03490-66504
A5	03490-66505		BOARD ASSY:RANGE SWITCH	28480	03490-66505
A6	03490-66506		BOARD ASSY:CONVERTER AC	28480	03490-66506
A7	03490-66507		BOARD ASSY:OHM CONVERTER	28480	03490-66507
A8	03490-66508		OUTGUARD POWER SUPPLY BOARD ASSY	28480	03490-66508
A9	03490-66509		INGUARD DATA OUTPUT BOARD ASSY	28480	03490-66509
A10	03490-66510		OUTGUARD DATA OUTPUT BOARD ASSY	28480	03490-66510
A11	03490-66511		INGUARD REMOTE ASSY	28480	03490-66511
A12	03490-66512		OUTGUARD REMOTE BOARD ASSY	28480	03490-66512
A13	03490-66513		RATIO REFERENCE BOARD ASSY	28480	03490-66513
A14			NOT ASSIGNED		
A15	03490-60306		DATA OUTPUT ISOLATION BOARD ASSY	28480	03490-60306
A16			NOT ASSIGNED		
A17	03490-60308		REMOTE ISOLATION BOARD ASSY	28480	03490-60308
A18			NOT ASSIGNED		
A19			NOT ASSIGNED		
A20			NOT ASSIGNED		
A21			NOT ASSIGNED		
A22	03490-60302		SYSTEM ISOLATION BOARD ASSY	28480	03490-60302
A23			NOT ASSIGNED		
A24	03490-66524		S/H ANALOG JUMPER ASSY	28480	03490-66524
A25	03490-66525		S/H LOGIC JUMPER ASSY	28480	03490-66525
A26	03490-66526		RATIO JUMPER ASSY	28480	03490-66526
A27	03490-66527		SAMPLE/HOLD ANALOG BOARD ASSY	28480	03490-66527
A28	03490-66528		SAMPLE/HOLD LOGIC BOARD ASSY	28480	03490-66528
A29	11118-66501		OUTGUARD TRIGGER ASSY	28480	11118-66501
A30	03490-66530		ASCII OUTGUARD ISOLATION ASSY	28480	03490-66530
A31	03490-66531		OUTGUARD OTHER BOARD ASSY	28480	03490-66531
A32	03490-66532		OUTGUARD ROM ASSY	28480	03490-66532
A33	03490-66533		OUTGUARD DATA ASSY	28480	03490-66533
A34	03490-66534		INGUARD ROM ASSY	28480	03490-66534
A35	03490-66535		ASCII INGUARD ISOLATION BOARD ASSY	28480	03490-66535
A36	03490-66536		INGUARD PROGRAM ASSY	28480	03490-66536
A37	11118-66502		SAMPLE/HOLD TRIGGER GATE ASSY	28480	11118-66502
C1	0160-3333	2	C:FXD CFR 5000 PF 20% 250WVAC	28480	0160-3333
C2	0160-3333		C:FXD CFR 5000 PF 20% 250WVAC	28480	0160-3333
CR1	1902-1232	1	OTIME BREAKDOWN:5.6V 10% 445 MA	80131	1N3997R
F1	2110-0312	1	FUSE:CARTRIDGE 1 AMP 250V SLOW-BLOW	71400	MDL-1
F2	2110-0202	1	FUSE:0.50A 250V SLOW-BLOW	75915	313-5005
J1, J2	1510-0536	4	BINDING POST ASSY	28480	1510-0536
J3	1510-0538	1	BINDING POST ASSY	28480	1510-0538
J4, J5	1510-0536		BINDING POST ASSY	28480	1510-0536
J6	1251-0087	1	CONNECTOR:FEMALE 50-PIN MINAT	28480	1251-0087
J7	1251-0085	1	CONNECTOR:FEMALE 36-PIN MINAT	28480	1251-0085
J10	1251-1232	1	CONNECTOR:MALE 4 PIN S/P PURPOSE	28480	1251-1232
J11	1251-0143	1	CONNECTOR:FEMALE 14-CONTACT JACK	28480	1251-0143
J12	1251-3283	1	CONNECTOR:24-PIN	28480	1251-3283
MP1	4040-0914	1	PANEL:FRONT	28480	4040-0914
MP1A	03490-04301	1	DECAL:FRONT PANEL (STANDARD)	28480	03490-04301
MP1B	03490-04302	1	DECAL:FRONT PANEL S/H	28480	03490-04302
MP1C	03490-04303	1	DECAL:FRONT PANEL RATIO	28480	03490-04303
MP1D	03490-04304	1	DECAL:FRONT PANEL - RATIO/S/H	28480	03490-04304
MP2	4114-0717	1	WINDOWS:DISPLAY	28480	4114-0717
MP3	03490-04119	1	GUARD-COVER-BOTTOM	28480	03490-04119
MP4	03490-04402	1	COVER:BOTTOM	28480	03490-04402
MP5	03490-28301	1	TRIM:BOTTOM	28480	03490-28301
MP6	03490-22001	1	FRAME:SIDE	28480	03490-22001
MP7	03490-23701	1	EXTENDER:ROD SWITCH	28480	03490-23701
MP8	03490-60312	1	PANEL ASSY:REAR	28480	03490-60312
MP9	03490-00601	1	SHIELD:POWER INPUT	28480	03490-00601
MP10	03490-60402	1	CHASSIS ASSY	28480	03490-60402
MP11	03490-04101	1	GUARD-COVER-TOP	28480	03490-04101
MP12	03490-04401	1	COVER:TOP	28480	03490-04401
MP13	03490-21101	1	HEAT SINK:TRANSISTOR	28480	03490-21101
MP14	0340-0782	1	INSULATOR:TRANSISTOR	28480	0340-0782
MP15	4040-0921	1	TRIM:TOP	28480	4040-0921

See introduction to this section for ordering information

Table 6-1. Replaceable Parts(Cont'd)

Reference Designation	HP Part Number	Qty	Description	Mfr Code	Mfr Part Number
MP16	5000-0593	1	COVER:STDF 3 X 16.100 (VF GRAY)	28480	5000-0593
MP17	5000-0050	1	TRIM:SLDS	28480	5000-0050
MP18A	03490-28302	1	FOOT:CNTR	28480	03490-28302
MP18	5060-0767	1	FOOT ASSY:FM	28480	5060-0767
MP19	1490-0030	1	STAND:TILT	28480	1490-0030
MP20	0370-0929	1	KNDR:LFVER,JADF GRAY(ALL)	28480	0370-0929
MP21	0370-2112	1	KNDR:ONE-HALF POINTER	28480	0370-2112
MP23	0370-2248	1	KNDR:ON/OFF	28480	0370-2248
MP24	0370-2367	1	KNDR:PUSHBUTTON MANUAL TRIGGER	28480	0370-2367
MP25	0510 1165	1	RING: RETAINER	00000	OBD
MP26	9320-1646	1	CARD: OPERATING, 60 HZ	28480	9320-1646
MP27	9320-1647	1	CARD: OPERATING, 50 HZ	28480	9320-1647
MP29	0340-0752	1	INSULATOR: BDG POST POLYC	28480	0340-0752
MP30	0360-0752	1	NUT: TERMINAL	00000	OBD
MP31	03490-84411	1	KIT: RACK MOUNT	28480	03490-84411
MP33	5060-0630	1	BOARD:EXTENDER 22 PIN (2X22)	28480	5060-0630
MP34	5060-5983	1	PC ASSY:EXTENDER 18 PIN (2X18)	28480	5060-5983
MP35	03490-04118	1	PLATE	28480	03490-04118
MP36	4040-0916	1	LFVER:FUNCTION SWITCH	28480	4040-0916
MP37	0370-0914	1	RFEL:PUSHBUTTON KNDR, JADF GREY	28480	0370-0914
MP38	0370-1099	2	KNDR:JADF GRAY	28480	0370-1099
MP39	0370-1099	1	KNDR:JADF GRAY	28480	0370-1099
MP40	5060-6032	1	PC BOARD:EXTENDER	28480	5060-6032
MP41	03490-64101	1	COVER: REAR TERMINAL	28480	03490-64101
MP42	0340-0744	4	INSULATOR: SUPPORT	28480	0340-0744
MP43	0340-0751	1	INSULATOR: BDG POST POLYC	28480	0340-0751
MP44	03490-01208	1	BRACKET: FRONT TERMINAL	28480	03490-01208
P1	1251-2357	1	SOCKET: 3-PIN MALE POWER RECEPTACLE	82389	EAC-301
P6	1251-0086	1	CONNECTOR: 50 CONTACT R & P	28480	1251-0086
P7	1251-0084	1	PLUG: 36-CONTACT MALE W/NOOD & CLAMP	28480	1251-0084
P10	1251-1233	1	CONNECTOR: GUARDED CABLE PLUG	28480	1251-1233
P11	1251-0142	1	CONNECTOR: MALE 14 CONTACTS	28480	1251-0142
O1	1854-0063	1	TSTR:SI NPN	80131	2N3055
R1	0811-2771	1	R: FXD WW 0.18 OHM 3% 3W	28480	0811-2771
S1	3101-1720	1	SWITCH: PUSHBUTTON DPDT SINGLE STATION	28480	3101-1720
S2	3101-1609	1	SWITCH: SLIDE 2-2 DPDT	82389	11E-1036
S3	3100-3078	1	SWITCH:FUNCTION	28480	3100-3078
S4			SFF ASSY		
S5	3100-3076	1	SWITCH:ROTARY	28480	3100-3076
S6	3100-2735	1	SWITCH:ROTARY	28480	3100-2735
S7	3100-2734	1	SWITCH:RATIO	28480	3100-2734
SR	3101-0045	1	SWITCH:SLIDE DPDT 0.5 AMP 12V V.R.	42199	11238
T1	9100 3495	1	TRANSFORMER	28480	9100-3495
W1	9120-1343	1	CABLE ASSY:POWER, DETACHABLE	70403	KHS-7041
W2	03490-61610	1	CABLE ASSY:AC	28480	03490-61610
W3	03490-61612	1	CABLE REAR INPUT	28480	03490-61612
W4	03490-61613	1	CABLE ASSY	28480	03490-61613
XF1	1400-0085	1	FUSEHOLDER	75915	342004
XQ1	1200-0479	1	SOCKET TSTR, NYLON INSULATOR	75263	4601
	0362 0280		CONNECTOR CRIMP	28480	0362 0280
	44090A	1	HP-IB SERVICE KIT INCLUDES:		
	03490-66532	1	OUTGUARD ROM ASSY	28480	03490 66532
	03490-66533	1	OUTGUARD DATA ASSY	28480	03490-66533
	03490-66534	1	INGUARD ROM ASSY	28480	03490-66534
	03490-66504	1	PC ASSY-REMOTE JUMPER BOARD	28480	03490-66504
	03490-66536	1	INGUARD PROGRAM ASSY	28480	03490-66536
	03490-69509	1	LIGHT ISOLATION ASSY	28480	03490 69509
	03490-80013	1	PARTS KIT FOR ISOLATION ASSY CONSISTING OF:	28480	03490-80013
	1540-0249	1	PLASTIC BOX	28480	1540-0249
	1820-0174	2	IC:TTL HEX INVERTER	01295	SN7404N
	1820-0513	1	IC:DIGITAL	01295	SN7409N
	1820-0586	3	IC:DIGITAL	12040	DM74L04N
	1820-0590	1	IC:TTL LP DUAL	12040	DM74L51N
	1820-0621	1	IC:TTL QUAD	01295	SN7438N
	1820-0640	1	IC:DIGITAL	01295	SN23623
	1820-0710	2	IC:DIGITAL	07263	SL17315
	1820-0876	1	IC:DIGITAL	01295	SN21957
	1854-0071	5	TSTR:SI NPN	28480	1854-0071
	1990-0402	5	TSTR:PHOTO	28480	1990-0402
	03490-80031	1	PARTS KIT FOR OUTGUARD MOTHER BOARD CONSISTING OF:	28480	03490-80031
	1540-0248	1	PLASTIC BOX	28480	1540-0248
	1820-0174	1	IC:TTL HEX	01295	SN7404N
	1820-0430	1	IC:LINEAR	28480	1820-0430
	1820-0586	1	IC:TTL LP HEX INVERTER	12040	DM74L04N
	1820-0621	1	IC:TTL QUAD	01295	SN7438N

See introduction to this section for ordering information

Table 6-1. Replaceable Parts(Cont'd)

Reference Designation	HP Part Number	Qty	Description	Mfr Code	Mfr Part Number
	1901-0363	1	DIO ASSY SI	28480	1901-0363
	03490-80032	1	PARTS KIT FOR OUTGUARD ROM ASSY CONSISTING OF:	28480	03490-80032
	1540-0248	1	PLASTIC BOX	28480	1540-0248
	1818-2097	1	MOS N CHAN ROM	28480	1818-2097
	1818-2098	1	MOS N CHAN ROM	28480	1818-2098
	1820-0567	1	IC: DIGITAL	04713	SC13241PK
	1820-0586	1	IC:TTL LP HEX INVERTER	12040	DM74L04N
	1820-0788	2	IC: DIGITAL	01295	SN35431
	03490-80033	1	PARTS KIT FOR OUTGUARD DATA ASSY CONSISTING OF:	28480	03490-80033
	1540-0248	1	PLASTIC BOX	28480	1540-0248
	1820-0174	1	IC TTL HEX INVERTER	01295	SN7404N
	1820-0583	1	IC:TTL LP QUAD	12040	DM74L00N
	1820-0591	2	IC:TTL LP	12040	DM74L54N
	1820-0596	4	IC: DIGITAL	12040	DM74L74N
	1820-0621	1	IC:TTL QUAD	01295	SN7438N
	1820-0627	2	IC:TTL LP	07263	U7893L0159X
	1820-0640	1	IC: DIGITAL	28480	1820-0640
	1820-0839	2	IC: DIGITAL	01295	SN35872
	1902-3030	1	DIO: BKDN 3.01 V	28480	1902-3030
	03490-80034	1	PARTS KIT FOR INGUARD ROM ASSY CONSISTING OF:	28480	03490-80034
	1540-0248	1	PLASTIC BOX	28480	1540-0248
	1818-2096	1	MOS N CHAN ROM	28480	1818-2096
	1820-0328	1	IC:TTL QUAD	04713	SN7402N
	1820-0596	2	IC: DIGITAL	12040	DM74L74N
	1820-0620	2	IC:TTL DUAL	01295	SN74153N
	1820-0777	1	IC: DIGITAL	28480	1820-0777
	1820-0788	1	IC: DIGITAL TTL HEX	01295	SN35431
	1902-3190	1	DIO: BKDN 13 V	28480	1902-3190
	03490-80036	1	PARTS KIT FOR INGUARD PROGRAM ASSY CONSISTING OF:	28480	03490-80036
	1540-0248	1	PLASTIC BOX	28480	1540-0248
	1820-0174	1	IC:TTL HEX INVERTER	01295	SN7404N
	1820-0511	1	IC:TTL QUAD	01295	SN7408N
	1820-0596	3	IC: DIGITAL	12040	DM74L74N
	1820-0600	1	IC:TTL LP	12040	DM85L90N
	1820-0640	1	IC: DIGITAL	28480	1820-0640
	1820-0656	2	IC:TTL LP	01295	SN74L98N
	1820-0777	1	IC: DIGITAL	28480	1820-0777
	1820-0839	1	IC: DIGITAL	01295	SN35872
	44090-90001		OPERATING NOTE	28480	44090-90001
	44090-64501		CARRYING CASE	28480	44090-64501
	03490-00605	1	SHIELD-AC	28480	03490-00605
	5951-7587		LABEL	28480	5951-7587

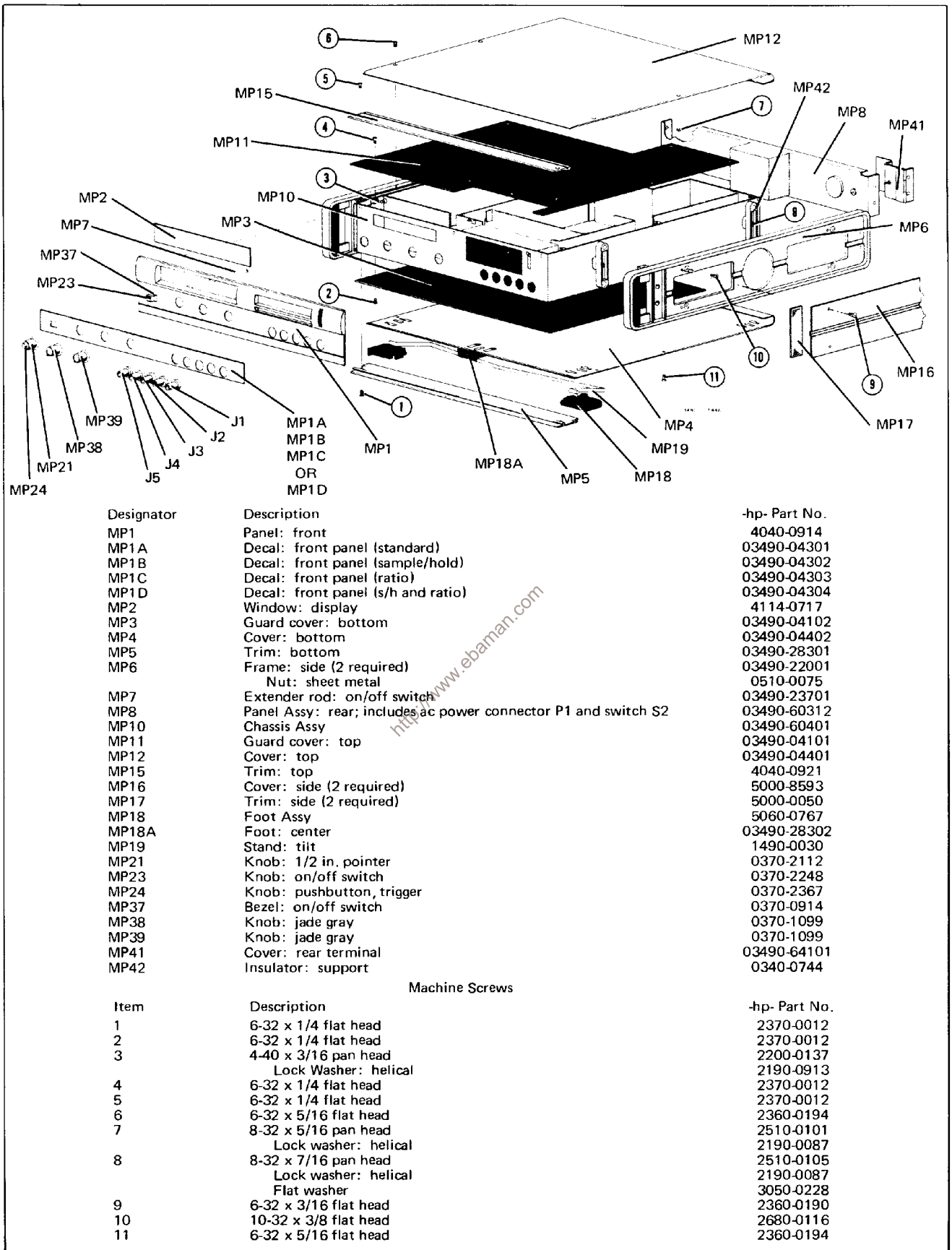

Figure 6-1. Chassis Parts.

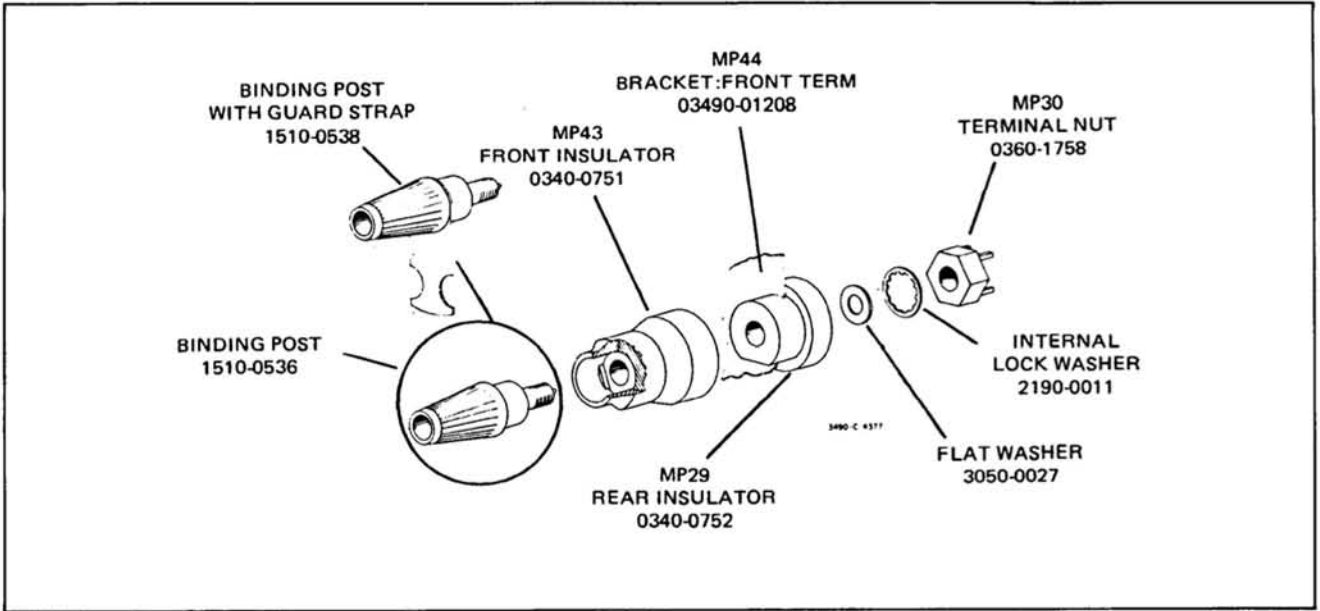

Figure 6-2. Binding Post Assembly.

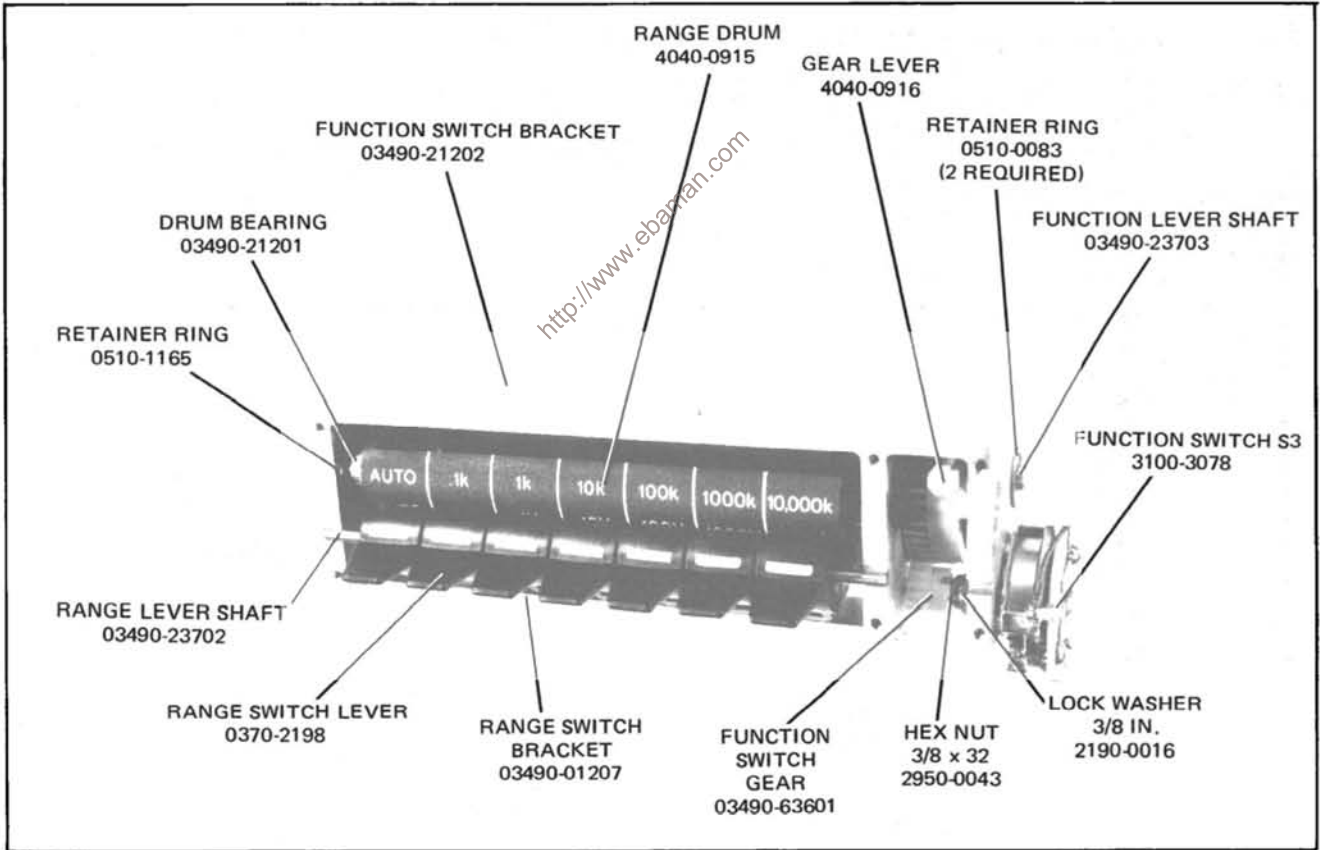

Figure 6-3. Switch Assembly.

SECTION VII TROUBLESHOOTING AND CIRCUIT DIAGRAMS

7-1. INTRODUCTION.

7-2. This section contains information necessary for repairing the Model 3490A. Schematic diagrams, troubleshooting trees, and other troubleshooting and repair information are included. Figure 7-17 shows the location of assemblies within the 3490A. Additional troubleshooting notes are located on schematics.

7-3. PRELIMINARY TROUBLESHOOTING.

7-4. If the Model 3490A operates incorrectly and the trouble cannot be corrected by the Adjustment Procedures, the following troubleshooting information should be used. Check for loose wires or other obvious sources of trouble, such as burned or loose components. Make sure printed circuit boards are seated firmly in connectors. Also make sure those microcircuit packages that mount in sockets are firmly seated.

7-5. TROUBLESHOOTING TREES.

7-6. Troubleshooting information for various circuits or operations of the 3490A is contained in several troubleshooting trees and associated information. The General Troubleshooting Tree, Figure 7-4, may be used to isolate the problem to a particular area of the instrument. The following list indicates the circuits to which each tree applies:

Troubleshooting Tree Title	Figure No.
Standard 3490A Circuits	
General	7-4
DC Analog	7-5
AC Converter	7-6
Ohms Converter	7-7
Display	7-8
Logic Test	7-9
Logic Clock	7-10
Option 021	
Data Output	7-11
Option 022	
Remote	7-12
Option 030	
HP-IB I/O	7-13
Option 040 or 045	
Sample/Hold General	7-14
Sample/Hold Logic	7-15
Option 080	
Ratio	7-16

7-7. ACCESS FOR SERVICING.

7-8. Access to most areas of the instrument may be gained by removing the top cover and the top guard cover. It should not be necessary to remove the bottom covers unless components on the Main Circuit Assembly, A1, must be replaced. Remove the top trim strip to gain access to the Display Assembly. The three vertical screws which secure the Display Assembly heat sink to the guard shield must be removed in order to remove the Display Assembly.



The High Impedance, AC Converter and the Ohms Converter printed circuit boards and components must be kept clean and free from fingerprints or other contamination, or performance may be degraded. Handle these assemblies by the board extractors.

7-9. POWER SUPPLY CHECKS.

7-10. Check the power supply voltages at the points listed in Table 7-1 using an oscilloscope and a dc digital voltmeter with 4-digit resolution. Voltage and ripple specifications are as shown. All ripple measurements are to be made with the sample rate in the HOLD position. Voltages are listed following the supply used as its reference. Therefore, power supply voltages should be checked in this order. The first supply checked which fails to meet the voltage specified is the faulty supply. All supplies referenced to the faulty supply will also indicate readings out of specification. With the faulty supply identified proceed to troubleshoot as follows:

- a. Pull options and install required jumper boards. If problem disappears, determine which option is at fault and proceed to its troubleshooting section.

Table 7-1. Power Supply Voltages and Current Limit Values.

Base Supply			
A1A1 Test Point	Voltage	Ripple	Current Limit (Approx. Voltages)
+17 V	+16.99 to +17.01 V	< 50 mV p-p	A1R104 = 434 V
-5 V	+ 4.995 to + 5.075 V	< 60 mV p-p	A1R1 = 448 V
+30 V	+30.10 to +30.90 V	< 25 mV p-p	A1R111 = 1.34 V
-17 V	-16.925 to -17.175 V	< 50 mV p-p	A1R118 = 54 V
-5 V	- 5.00 to 5.85 V	< 60 mV p-p	
-30 V	-30.10 to -30.90 V	< 25 mV p-p	A1R125 = 1.30 V

Raw Supply			
Test Point	Supply	Voltage	Ripple (Approx. Voltage)
TPD	+24 V	-24 to +28 V	1 V p-p
	-24 V	-24 to 28 V	1.2 V p-p
	+38 V	+38 to +44 V	5 V p-p
TPA	-38 V	-38 to -44 V	5 V p-p
TPC	+9 V	+9 to +11 V	1.5 V p-p

b. If the problem is not with an option, determine if the faulty supply is in current limit (see Paragraph 7-12). If so, determine where the short is by use of the power supply jumpers and troubleshoot that section.

c. If the faulty supply is not in current limit, determine if the faulty supply has the correct raw supply voltage (see Table 7-1). If the raw supply does not meet specification, troubleshoot this section.

d. If the faulty supply is not in current limit and the raw supply is within specification, troubleshoot the faulty supply.

7-11. If the + 17 V supply is out of specification and cannot be adjusted per Paragraph 5-54, troubleshoot according to Paragraph 7-10, steps a, b, c and d. It is essential that the + 17 V supply be within specification since all other supplies are referenced to this supply and will be affected. If oscillation problems are encountered on the + 17 V supply, change A1C109 to 1000 pF, 400 pF or remove from circuit. If there are ripple problems on the + 17 V supply or any other supply, check to assure the line voltage selection switches are set to correspond with available line voltage. If ripple still exists, replace the filter capacitor of faulty supply. Ripple problems on the - 17 V supply can be caused by ripple or low voltage of the - 30 V supply (lower voltage than the - 24 V raw voltage supply).

7-12. All power supply regulators are current limited so that if an excessive load is applied, the regulator voltage output goes to near zero. If this is suspected to be the problem, the supply in current limiting can be determined by measuring for the current limit voltage across the resistor which are both specified in Table 7-1. Provision has been made for isolating certain areas of the Main Circuit Assembly by removing designated jumper wires in order to locate the area where excessive loading occurs. Table 7-2 lists the jumper wire designations and the circuits supplied through each. These jumpers are located on the Main Circuit Assembly, A1 and the vertical board, A1A1. All of the Logic circuits are supplied through only one jumper wire for each voltage. Consequently, jumper wires are provided in the ground circuits to isolated portions of the logic circuits. These ground jumpers are shown on the schematic diagrams, Figure 7-23 and 7-24.

7-13. DC ANALOG CIRCUITS.

7-14. The DC Analog Troubleshooting Tree, Figure 7-5, covers the DC Amplifier, Integrator and Zero Detect circuits, ± 10 V References, the DC Switching Logic and Level Translators and the Power Supplies.

7-15. A2 Assembly Exchange.

7-16. Cleanliness of the A2 High Impedance Assembly and the proper positioning of components on the assembly are highly important to the performance of the instrument. Also, A2U2 is very difficult to replace. Consequently, a rebuilt High Impedance Assembly, -hp- Part No. 03490-69502, has been made available to

Table 7-2. Power Supply Jumper Wires.

Voltage	Wire	Location	Circuits Supplied
+ 17 V	WH	A1	Logic
+ 17 V	W2	A1A1	± 10 V Reference
+ 17 V	W6	A1A1	Integrator, Zero Detect
- 17 V	W1	A1	Logic
- 17 V	WEE	A1	DC Switching Level Translators
- 17 V	W3	A1A1	±10 V Reference
- 17 V	W8	A1A1	Integrator, Zero Detect
+ 30 V	WZ	A1	Integrator, Zero Detect
+ 30 V	WBB	A1	DC Amplifier
+ 30 V	W4	A1A1	± 10 V Reference
- 30 V	WAA	A1	Integrator, Zero Detect
- 30 V	WCC	A1	DC Amplifier
- 30 V	WFF	A1	DC Switching Level Translators, A1CR403
+ 5 V	WJ	A1	Logic, Display, Switches
+ 5 V	W1	A1A1	A1U401, Overload Protection, DC Switching Logic
+ 5 V	W7	A1A1	Integrator, Zero Detect
- 5 V	WG	A1	Logic
- 5 V	W5	A1A1	Integrator, Zero Detect.

facilitate repair of your 3490A when the trouble is on the A2 Assembly. Contact your nearest -hp- Sales and Service Office for details.

7-17. DC Amplifier Checks.

7-18. To check the DC Amplifier zero, set the Function switch to TEST and select Range 5. This grounds the amplifier input and sets the amplifier gain to 100. The front panel display should be 000.000 ± 15 counts. To check for leakage current in the input circuits, compare the numerical reading in Test 5 to the reading in Test 6 with the input terminals shorted. If the reading in Test 6 is somewhat higher (ignoring the decimal point), check for leakage current. Remember that no soldering should be done on the A2 Assembly (see Paragraph 7-14).

7-19. If the DC Amplifier cannot be adjusted to zero in Paragraph 5-60 step b, it is possible that there may be leakage to Guard from some point in the circuits. Disconnect the Guard shorting strap from the input Low terminal. If the offset is removed or can then be adjusted to zero, leakage to Guard is probable. Some of the possible causes are: 1) Breakdown of the insulation for power transistor Q1 or CR1. 2) Leakage to Guard in the power transformer. Disconnect the small orange wire from the transformer cable to the solder lug on the Guard shield to check this. 3) If the instrument has one of Options 020, 021, 022, 030 or 040, there may be leakage to Guard on the isolation assembly. 4) A wire clipping or other metal chip may be wedged between the Guard shield and the Main Circuit Assembly A1.

7-20. Normal operating voltages within the DC Amplifier are shown on the schematic diagram, Figure 7-20. To check the operation of various stages of the amplifier, first set the Sample Rate control to HOLD and disconnect the Bootstrap Amplifier (white jumper wire, labeled "Bootstrap" on the A2 Component Loca-

tion drawing). Connect the gates of both A2Q1A and B to ground. Connect a dc null meter (-hp- 419A) between A1TPR and ground, and adjust A1R522 from one extreme to the other. If this point adjusts both positive and negative, the amplifier is probably operating correctly, and the Bootstrap Amplifier should be checked. If A1TPR will not adjust both positive and negative, connect the dc null meter between the source of A2Q1B and add adjust A1R522 to both extremes. The voltage should adjust both positive and negative. Each stage of the amplifier can be checked in the same manner, connecting the dc null meter between the collectors of A1Q509A and B, the emitters of A1Q505 and A1Q508, the collectors of A1Q506 and A1Q507, or the emitters of A1Q510 and A1Q511.

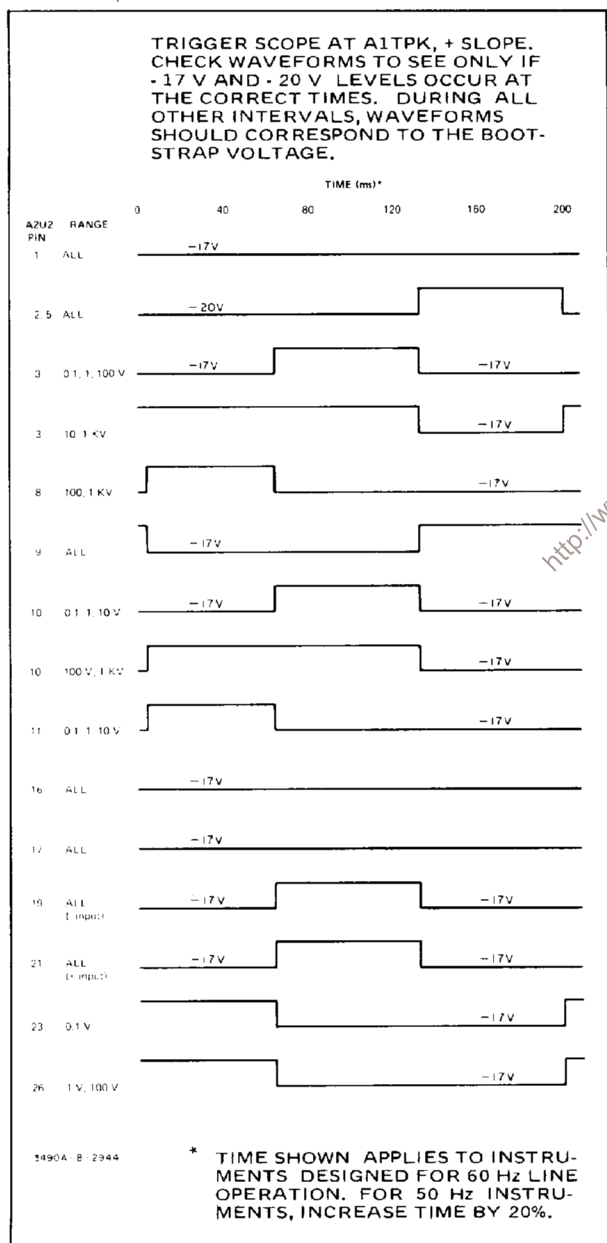

Figure 7-1. Switching Inputs to A2U2.

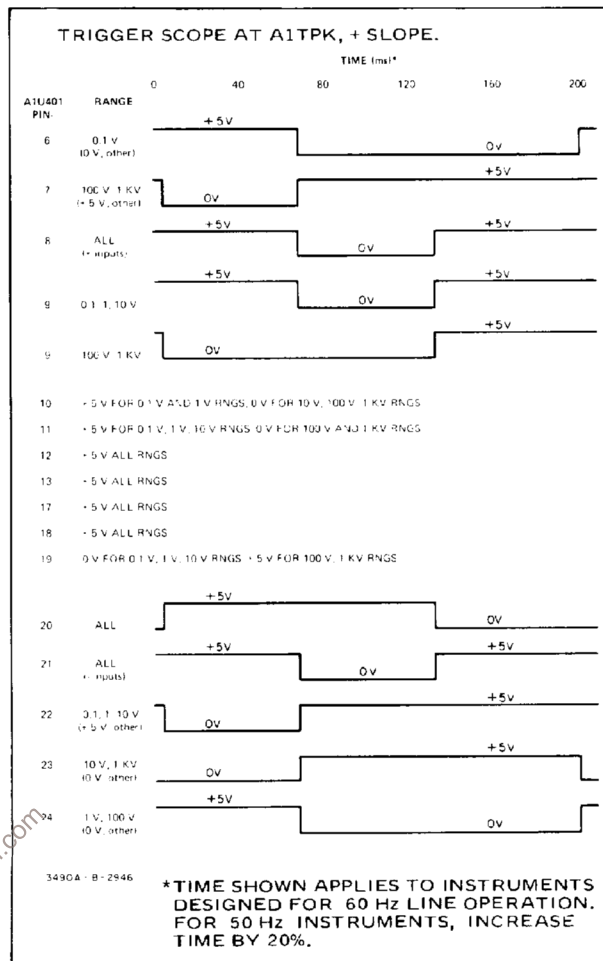

Figure 7-2. Switching Outputs of A1U401.

7-21. After these checks and following repair of the DC Amplifier, the DC Amp. Zero control should be adjusted using the following procedure:

- a. Set 3490A FUNCTION to TEST, RANGE to 2, SAMPLE RATE to FAST.
- b. Connect a clip lead across A2C3.
- c. Adjust A1R522 for a display of +.000010 to -.000026.

7-22. DC Amplifier Switching Circuits.

7-23. Figure 7-1 shows the inputs to the DC Amplifier input switching FET's. Waveforms at the connections to A2U2 should be compared to the bootstrap waveform at the white jumper on A2 (labeled "Bootstrap" on the Component Location drawing). The "OFF" voltage level of -17 V or -20 V must be correct. During the "ON" time, when the waveform is more positive than -17 V, the waveform should correspond to the bootstrap waveform.

7-24. The switching outputs of the DC Logic ROM, shown in Figure 7-2, should be as shown in each case.

7-25. Replacement of QCR301.

7-26. If it is necessary to replace the reference transistor diode package A1QCR301, it is also necessary to replace resistors A1R306, 308, 310, 313, 314 and 315, which are matched to QCR301. Matched resistors are supplied with the replacement reference, QCR301.

7-27. A-to-D CONVERSION CIRCUIT CHECKS.

7-28. The Analog-to-Digital (A-to-D) Conversion circuits consist of the Integrator, the x20 Amplifier, and the Zero Detect circuits. Some problems in these circuits may be detected by applying a full-range input voltage. For example, the Integrator output waveform at A1TP1 may be checked with a -10 V input on the 10 Vdc range. The center portion of the waveform (10 ms between run-up and run-down) should be flat. If this portion decays, this may indicate leakage in the Integrator capacitor, C203. If the waveform continues to rise, the input switches Q204 and Q205 may not be completely cut off during this period.

7-29. Some types of problems, such as amplifier offset or failure, may be found by setting the Sample Rate control to HOLD and making dc voltage measurements within the circuits. For instance, both inputs to an operational amplifier should be equal and near zero. To check the balance of a dual FET, such as Q206 for example, first remove the microcircuit amplifier (U201 in this case) from its socket. Connect both FET gates to ground, and measure the source voltages, which should be equal. These voltages may be measured at pins 2 and 3 of the open U201 socket.

7-30. With the instrument sampling and with a full range input, the x20 Amplifier output should not exceed 1.2 to 1.4 V because of the diodes between the amplifier input and output. Also with a full-range input, the zero detect reference voltage at pin 3 of U203 should be approximately ± 50 mV during run-up and run-down. Non-linearity of negative readings may be caused by a defective amplifier, U201.

7-31. INTEGRATOR TROUBLESHOOTING.

7-32. The integrator may cause noise on full scale readings in the dc mode. If this occurs, check A1R207, Q206, Q207, U201 and U202. If there is noise at low input levels (ie., 100 mV input on 10 V dc range), check A1C207. A1Q209 will be very noisy if pinch-off voltage is not correct. To check for a noisy Q209, increase the +17 V supply and observe noise. The increase in the +17 V supply increases the bias on Q209. If the noise disappears at a higher +17 V supply voltage, Q209 should be replaced. Readjust the +17 V supply per Paragraph 5-54.

7-33. AC CONVERTER TROUBLESHOOTING.

NOTE

The indication on all ranges with the input shorted will not be zero but should be less than 50 counts.

Table 7-3. AC Reed Relay Checks.

Ranges Affected	Symptoms	Possible Causes
100 V 1000 V	Overload — 1 V input on 100 V range results in 100 V display	K2 Shorted
1 V 10 V	Display is one-half the input value	K2 open
1 V 10 V	Low input impedance, approx. 20 kΩ	K3 shorted
100 V 1000 V	Overload — 1 V input on 100 V range results in 50 V display.	K3 open
1 V 100 V	Display is 1/10 the input value	K4 shorted
10 V 1000 V	Overload	K4 open

7-34. Operation of the AC Converter circuits may be checked using the Troubleshooting Tree, Figure 7-6. Table 7-3 lists a number of symptoms associated with reed relay failures.

7-35. Cleanliness of certain components and areas of the AC Converter Assembly are critical to the performance of the AC Voltmeter circuits. The assembly should be handled only by the board extractors, and should be cleaned thoroughly following any repair.

7-36. Certain components on the AC Converter Assembly must be spaced the correct distance from the printed circuit board for proper operation of the circuit. Table 7-4 lists these components and the proper spacing that must be observed during repair.

Table 7-4. Component Spacing.

Designator A6-	Spacing from Component Center to Printed Circuit Board	
	Minimum	Maximum
C1	0.1 in	0.2 in
C2	0.1 in	0.2 in
C3	0.1 in	0.2 in
C5	0.1 in	0.2 in
R1A	0.4 in	0.5 in
R1B	0.1 in	0.2 in
R4A	0.4 in	0.5 in
R4B	0.1 in	0.2 in
R4C	0.1 in	0.2 in

7-37. OHMS CONVERTER TROUBLESHOOTING.

7-38. The Ohms Converter Troubleshooting Tree, Figure 7-7, may be used to locate the trouble if the Ohms Converter does not operate correctly. Make sure the DC Voltmeter operation is correct before beginning the Ohms Converter checks.

7-39. The cleanliness of some areas of the Ohms Converter Assembly is important to proper operation. Handle the printed circuit board only by the extractors, and clean the repaired area thoroughly.

7-40. DISPLAY TROUBLESHOOTING.

7-41. The Display Troubleshooting Tree, Figure 7-8, may be used to troubleshoot a defective display. The numerical display units and the polarity unit may be most easily checked by substituting a known good unit. Access to the Display Assembly is gained by removing the 3490A top trim strip and the three vertical screws securing the display heat sink to the guard shield.

7-42. LOGIC TROUBLESHOOTING SUGGESTIONS.

7-43. Several microcircuits in the logic section may be checked by observing the inputs and outputs of the device. The "Q" output of a D flip-flop, for example, should agree with the "D" input if the flip-flop is being clocked. (See AIU6, 7, 11, 14, 17, 20 and 22.) The output is changed by the "0" to "1" transition of the clock input. Also, the output of an inverter (AIU8 and 10) should be the logical inverse of its input.

7-44. If incorrect readings are observed on the logic test, pull AIU2, 3, 9 and 16 and restate, taking care to seat leads properly in their sockets. AIU2, 3, 9 and 16 may be checked by substituting a known good device.

7-45. Certain microcircuits may be associated with particular malfunctions. AIU19 and 21 deal with programming the 3490A range and function. AIU15 and 24 are associated with sampling and sample rate delays. AIU15 also deals with function delays.

7-46. If decimal point or ranging problems cannot be located by using the troubleshooting trees, the trouble may be in the display, the front panel switching, or the optional Remote Assembly. The decimal points in the display are switched during the LOW true enable signals to the display units (see Figure 7-8).

7-47. If the instrument does not sample, the logic circuits may be locked in a certain state or sequence. Turn the instrument off. While holding the manual pushbutton depressed, turn the instrument back on and observe the states of logic signals YMA through YMG with an oscilloscope (see Figure 7-24). These are found at test points O, T, P, S, Q, N and J in the logic section of the main circuit board. Test point O should be a steady HIGH, and all others LOW. If these levels are not correct, the Read Only Memory, AIU9, or one of the State Storage flip-flops may be defective. If all seven signals are correct, release the pushbutton and check the test points again with the oscilloscope. If all levels are the same as before (TPO HIGH and all others LOW), the normally closed contacts of the pushbutton switch may not be making contact. Check to see if the pushbutton is binding in the center of the Sample Rate knob.

7-48. DATA OUTPUT TROUBLESHOOTING (Option 021).

7-49. Certain types of failures in the output information may be traced to certain circuits in the Data Output Assemblies. Table 7-5 lists a number of symptoms and

Table 7-5. Data Output Troubleshooting Tips.

Symptoms	Probable Cause
Measurement Information:	
No data output	A9U9
No data output and no polarity, overload, or overrange	A9U6
No odd numbers in any digit	A10U1, 2, 3, 7
No 2's, 3's, 6's, or 7's in any digit	A10U1, 2, 4, 7
No 4's, 5's, 6's, or 7's in any digit	A10U1, 2, 5, 7
No 8's or 9's in any digit	A10U1, 2, 6, 7
Range Information:	
No range data output	A9U7
No range and no function data output	A9U6
No odd numbered range data	A10U3
Ranges 2, 3, and 6 do not print correctly	A10U4
Ranges 4, 5, and 6 do not print correctly	A10U5
Function Information:	
No function data output	A9U7
No function and no range output	A9U6
Functions 1, 3, 5, 7, 9, -, A, and * not correct	A10U3
Functions 2, 3, 6, 7, +, -, Ω, and * not correct	A10U4
Functions 4, 5, 6, 7, V, A, Ω, and * not correct	A10U5
Functions 8, 9, +, -, V, A, Ω, and * not correct	A10U6
Polarity, Overload, Overrange, Sample/Hold, and Remote Mode Information:	
None of the above outputs correct	A9U7
None of the above and no range output	A9U6
No polarity output	A10U5
No overload output	A10U6
No overrange output	A10U3
No Sample/Hold Mode output	A10U6
No Remote Mode output	A10U6

their probable causes. Refer also to the Data Output Troubleshooting Tree, Figure 7-11.

7-50. REMOTE CONTROL TROUBLESHOOTING (Option 022).

7-51. Refer to the Remote Troubleshooting Tree, Figure 7-12, for information for troubleshooting the remote control circuits.

7-52. HP-IB TROUBLESHOOTING (Option 030).

7-53. General Checks.

7-54. If the 3490A with Option 030 does not operate correctly, first determine whether the trouble is in the I/O circuit or the main 3490A circuits. The performance checks in Section V may be used to determine whether the instrument operates properly in standard multimeter operation. Make sure the I/O plug-in printed circuit boards are seated properly in their sockets, and that the ribbon cable connectors are inserted properly. Also make certain that all microcircuit packages are seated firmly in the sockets.

7-55. Troubleshooting Method.

7-56. The logic circuits which make up the HP-IB option are very difficult to troubleshoot by the normal component method of troubleshooting. Consequently, an HP-IB Service Kit, -hp- Part No. 44090A, has been made available to facilitate fast and efficient on-site and bench repair of the HP-IB I/O Option. The HP-IB Service Kit consists of six assemblies (-hp- Part No. 03490-66504, -66509, -66532, -66533, -66534 and -66536), and six parts kits (-hp- Part No. 03490-80013, -80031, -80032, -80033, -80034 and -80036), which are individually available. See Table 6-1 for description of assemblies and parts kits. This table also provides a

breakdown of individual components contained in the Service Kit and their respective parts kits. The printed circuit assemblies provided in the repair kit may be substituted for assemblies in the instrument in order to isolate the trouble. A kit of microcircuit packages for each assembly is provided so that once the trouble has been isolated to an assembly, the defective microcircuits on that assembly may be replaced. A system controller and a printer are required for troubleshooting the I/O circuits. These may be the controller and printer in the system in which the 3490A is used. A dc voltmeter is also required. The HP-IB Troubleshooting Tree, Figure 7-13, checks most of the 3490A I/O circuits.

7-57. External Trigger Circuit Check.

7-58. The external trigger circuits may be checked by the following procedure.

a. Place 3490A in local control by setting the Remote Control Enable line (REN) to HIGH.

b. Set front panel SAMPLE RATE control to HOLD. Check logic level of External Trigger Flag (LETf) at J11 pin 4. Measure to outguard ground at pin 8 or 14 of J11, or on Outguard Data Assembly A33. LETf should be LOW until an external trigger command is given. If not, check A31Q1.

c. Momentarily connect J11 pin 7 to outguard ground. 3490A should sample each time pin 7 is grounded. If not, check A31Q2 and associated components, including pulse transformer T1. If the instrument does not have the Sample/Hold option, a jumper should be installed in place of T1. Make sure this jumper is seated properly in the correct sockets.

7-59. SAMPLE/HOLD SERVICING.

7-60. Access to Sample/Hold Circuits.

7-61. The Sample/Hold Analog and Logic printed circuit assemblies, A27 and A28, are fastened together and must be removed from their sockets as a unit. Printed circuit extender boards (Part Nos. 5060-6032 and 5060-5983, supplied with the 3490A Option 040/045) may be used to mount the Sample/Hold assemblies high enough for access to the circuits. The metal shield covering the Logic assembly may be removed without separating the two assemblies. Do not separate these assemblies unless it becomes necessary in order to replace components.



The Analog Assembly, A27, especially those areas in the vicinity of the teflon insulators, must be kept clean and free from fingerprints or other contamination, or Sample/Hold performance may be degraded.

7-62. If it becomes necessary to separate the Sample/Hold printed circuit assemblies in order to replace certain components, it is preferable not to disassemble more than necessary. For example, if a repair is to be made to the Analog Assembly, A27, the flexible shield should not be removed from A28. If the unit has been disassembled, use the following procedure and Figure 7-3 for reassembly.

a. Place Logic Assembly A28 (item 3 in Figure 7-3) component side down on work surface. Place 4 spacers (item 4) over the four captive spacers in A28.

b. Carefully put flexible shield in place, aligning holes in shield with the spacers.

c. Secure shield to A28, using two nylon screws (item 6) in the two holes nearest the bottom edge of A28. *These screws must be non-metallic.*

d. Place two spacers (item 4) on top of the other two holes in flexible shield.

e. Place Analog Assembly, A27, component side up over the two spacers in step d and secure with the screws (item 8).

f. Secure aluminum shield (item 2) over component side of A28, using four screws (item 1).

g. Connect brown, red and orange wires from A28 to pins 1, 2 and 3, respectively, on A27.

7-63. Operating the 3490A with Sample/Hold Assemblies Removed.

7-64. If a problem exists in the Sample/Hold circuits which affects operation of the 3490A with Sample/Hold off, the S/H Analog and Logic Assemblies, A27 and A28, may be removed and replaced by jumper boards, which are supplied with the Sample/Hold option. These boards complete the circuits necessary to allow the 3490A to operate (see Figure 4-27). The wire disconnected from the Analog assembly must be connected to the pin on the Analog Jumper Board for proper operation. Five pins are also provided at the left end of the Logic Jumper Board for terminating the wires disconnected from the Logic assembly. These pins are not connected to any circuitry.

7-65. SAMPLE/HOLD TROUBLESHOOTING TREES.

7-66. Two troubleshooting trees are provided to assist in isolating problems in instruments with Sample/Hold. The S/H General Troubleshooting Tree, Figure 7-14, is designed to determine if the trouble is in the Sample/Hold circuits or in other circuits in the 3490A. If it is determined that the trouble is indeed in the Sample/Hold circuits, this tree will also help determine whether it is in the analog or logic circuits. The Logic Troubleshooting Tree, Figure 7-15, provides further assistance in isolating trouble in the Sample/Hold logic circuits.

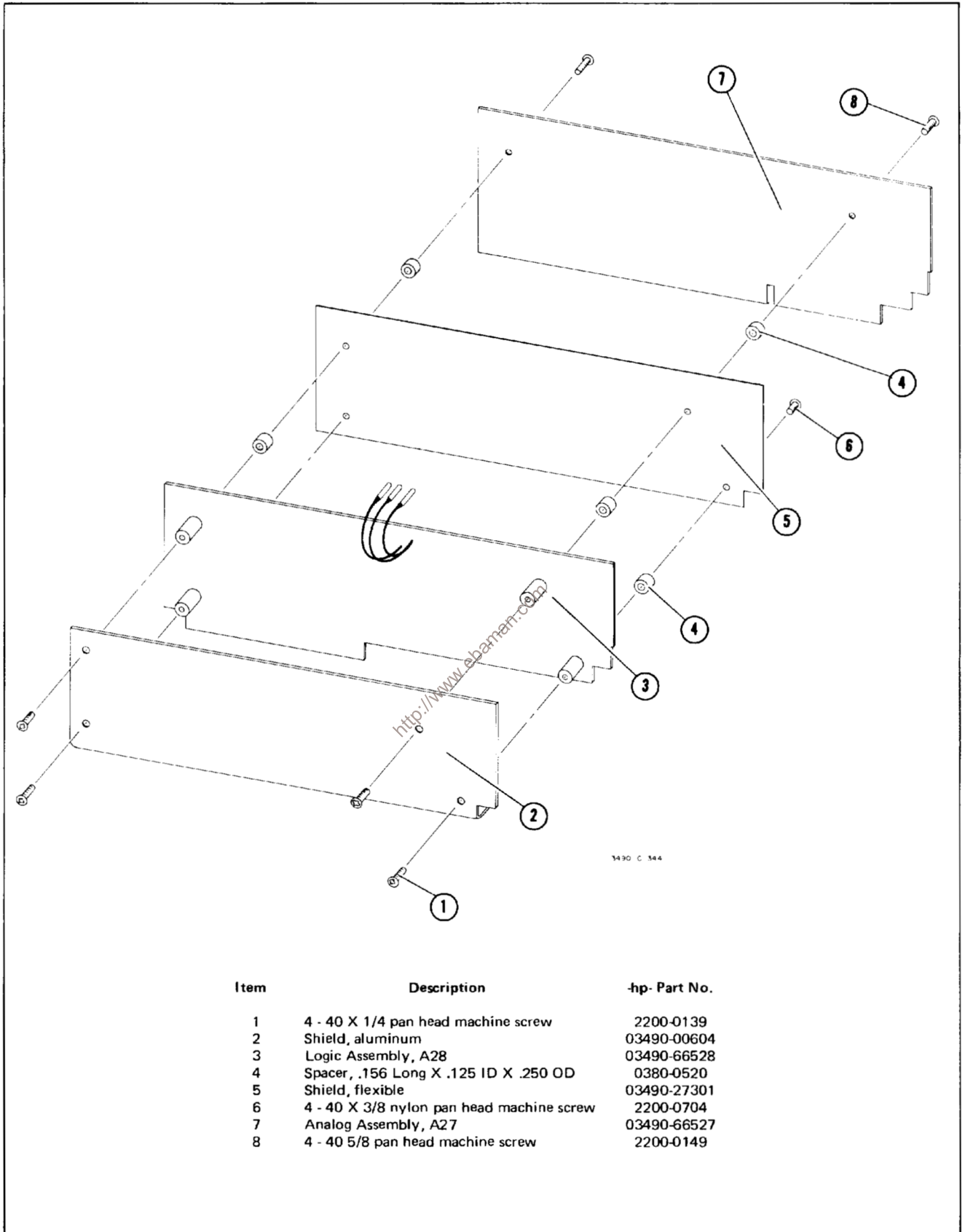

Figure 7-3. Sample/Hold Assembly.

7-67. RATIO TROUBLESHOOTING.

7-68. If ratio measurements are not correct and the trouble cannot be corrected by the Adjustment Procedure, or if the adjustments cannot be made correctly, the following troubleshooting information should be used. Check for obvious sources of trouble, such as burned or loose components or loose wires. Make sure the printed circuit board, A13, is seated firmly in its connector, and that the cable, W8, and the three operational amplifiers are seated firmly in their sockets.

7-69. External Reference Amplifier Checks.

7-70. The Ratio Troubleshooting Tree, Figure 7-16, checks the External Reference Amplifier circuits. However, correct interpretation of the display symptoms is needed to determine if the trouble is in the amplifier or logic circuits. For example, if the display reads approximately 75% of normal (10 V Input/10 V Ext. Ref. ≈ 07.5000), the trouble is probably in the amplifier circuits. If the display reads Overload for both positive and negative inputs (at INPUT terminals), the trouble is probably in the amplifier circuits, but if it reads Overload for only one input polarity, the trouble is more likely in the logic circuits. If the displayed polarity is incorrect and the display reads Overload, check the polarity logic circuits.

7-71. Amplifier Zero Offset.

7-72. If the Reference Amplifier zero adjustments in steps a through h of the Ratio Adjustment Procedure cannot be made correctly, the trouble may be leakage in either A13CR2 or 3. This condition can be most easily checked by unsoldering one lead of each diode and trying the zero procedure again. If the amplifiers can be zeroed with the diodes disconnected, one or both of them is defective.

7-73. Reference Polarity Logic Checks.

7-74. In the 3490A measurement system, if the Input voltage is positive, a negative reference is required for run-down, and vice versa. In ratio measurements, the applied External Reference voltage is inverted and these two voltages are substituted for the positive and negative internal reference voltages. The Reference Polarity Logic on the Ratio Assembly, A13, makes it possible to use either polarity External Reference input with either polarity Input voltage by selecting the correct reference polarity for run-down. If a failure in the Reference Polarity Logic causes the reference voltage used for run-down to be the same polarity as the Input, the display will indicate Overload. If the 3490A operates correctly in dc voltage measurements with inputs of both polarities, but reads Overload with one polarity input in ratio measurements, check the Reference Polarity Logic as follows:

- a. Set RATIO switch to EXT REF 10 V and apply 10 V to EXT REF terminals.

- b. Set FUNCTION to DC and apply full-range input on either the 1 V or 10 V range. Select the combination of INPUT and EXT REF polarity that causes the display to read Overload.









- c. Set SAMPLE RATE to HOLD. Check logic levels within Reference Polarity Logic circuits as indicated on the schematic diagram, Figure 7-22. Logic HIGH = + 2.4 V to + 5 V; LOW = 0 to + 0.6 V.

7-75. SCHEMATIC NOTES.

7-76. The following notes apply in general to all schematic diagrams:

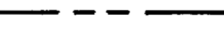
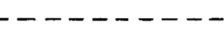
- a. Partial reference designations are shown. Prefix with assembly or subassembly designation(s) or both for complete designation.
- b. Component values are shown as follows unless otherwise noted:

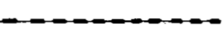
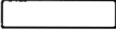
Capacitance in microfarads
Resistance in ohms

- c. * Average value shown. Optimum value selected at factory.
- d.  Denotes earth ground.
- e.  Denotes chassis or frame ground.
- f.  Denotes floatable circuit ground.
- g.  Denotes printed circuit assembly ground.
- h.  Denotes assembly outline.
- i.  Denotes subassembly outline.
- j.  Denotes main signal path.
- k.  Denotes feedback path.
- l.  Denotes front panel markings.
- m.  Denotes screwdriver adjust.
- n. 924 Denotes wire color. Color code is the same as the resistor color code. First number identifies the base color; second identifies the wider strip; and third number identifies the narrower strip (e.g. 924 = white, red, yellow).
- o. **3** Denotes schematic number on which connection is made.
- p.  Refer to manual backdating, Section VIII.

7-77. LOGIC GATE SYMBOLS.

7-78. A number of logic gate integrated circuits are used in the 3490A. Most of these are TTL circuits, in which the HIGH logic level is $\geq +2.4$ V and LOW is $\leq +0.5$ V. The normal symbol used to indicate a 2-input NAND Gate is shown below, accompanied by the truth table.

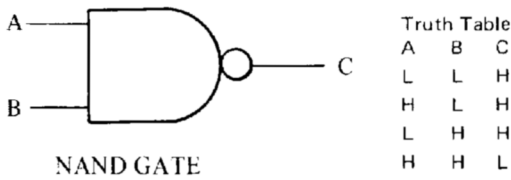

As the truth table indicates, both inputs must be HIGH (true) to obtain a LOW output. The purpose of the circle (invert symbol) at the gate output might then be assumed to indicate that the signal is LOW true at that point. The truth statement for this NAND Gate may be restated to read, "A LOW signal at either input results in a HIGH output," and the same truth table applies. In keeping with this statement and the use of the circle to indicate a LOW true signal, the following "OR" function symbol may be used.

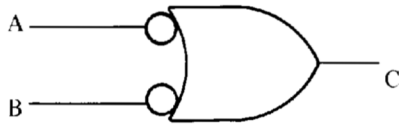

In some cases, a NAND Gate circuit may be used to invert a logic signal. This may be done by connecting the same signal to both inputs. If this is done, the following symbol may be used, indicating that the circuit merely inverts the signal.

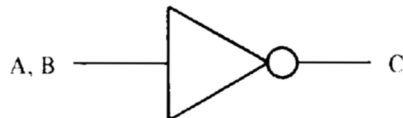

If the input signal is LOW true, the circle may be placed on the input side of the symbol.

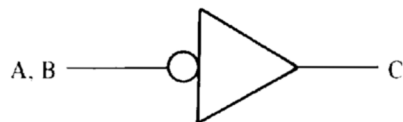

The NAND Gate may also be used as an inverter by connecting one input permanently to HIGH (+ 5 V). In this case, the circuit may be shown as follows.

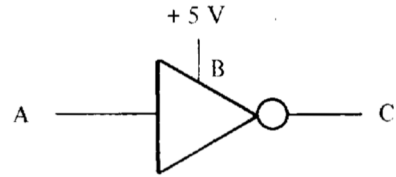

Note that the same truth table applies, and that if one input is held HIGH, the output is the inverse of the other input.

7-76. Another gate circuit used is the Exclusive OR Gate, normally drawn:

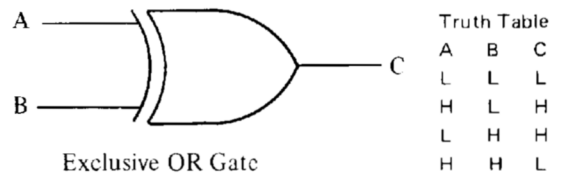

Note from the truth table that the output is HIGH if one, and only one, input is HIGH. When both inputs are either HIGH or LOW, the output is LOW. If one input is held LOW (connected to ground, for example) at all times, the output follows the other input. When used in this manner, this symbol may be used.

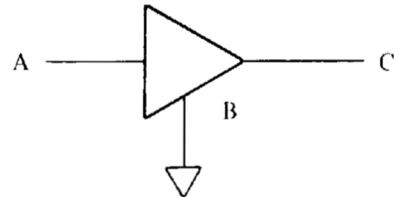

If one input is held HIGH (+ 5 V), an inverter symbol may be used, because the output becomes the inverse of the input.

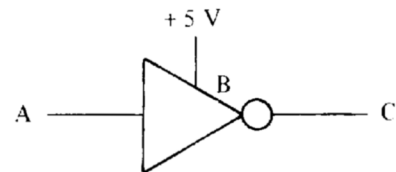
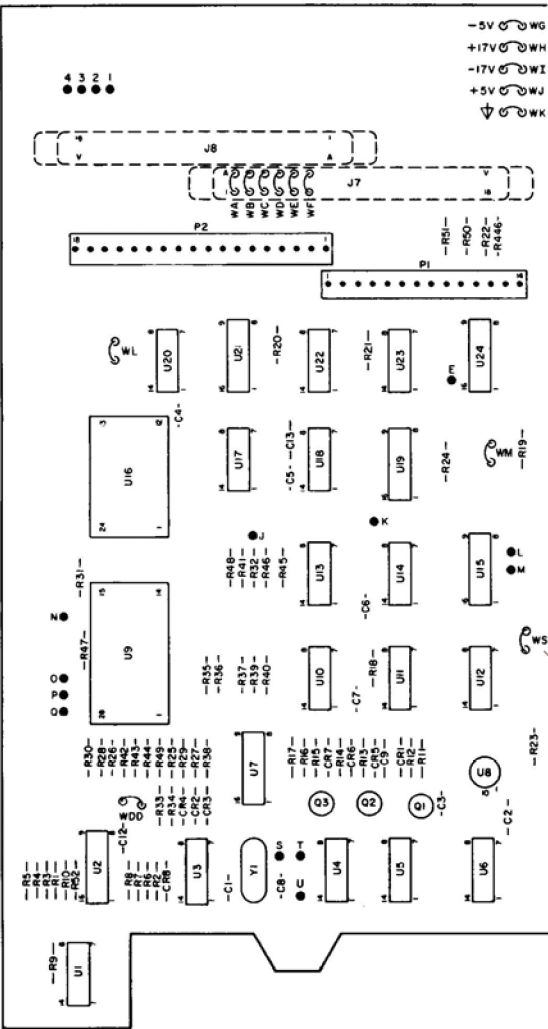

Table 7-6. Alphabetical Listing of 3490A Mnemonics.

Mnemonic	Description	Source	Mnemonic	Description	Source
LACI	AC input enable	A1U401	LEOR	End of reading	U14
LACO	AC converter output switch	A1U401	LEXE	External encode	A22U1
HAUT	Internal autorange	From HFAT or A11U11	HFAT	Front panel autorange	S4A
HAZD	Analog zero detect	A1U203	HFFA	Front panel function bit A	S3
LCDC	Clear data counter	A1U16	HFFB	Front panel function bit B	S3
HCDC	Clear data counter	A1U23	HFRA	Front panel range bit A	S4 or A11U11
LCDF	Change data flag (HDFL)	A1U16	HFRB	Front panel range bit B	S4 or A11U11
LCER	Change end of reading (LEOR)	A1U16	HFRC	Front panel range bit C	S4 or A11U11
HCES	Close electronic switch	A1U9	HFSC	Fast state clock	U3
LCHC	Change hundred thousand count select (HSHC)	U16	LFTX	False transfer	U16
LCMA	Change main time bit A (HMTA)	U16	LHNG	X100 Gain	U401
LCMB	Change main time bit B (HMTB)	U16	LHLD	Hold (stops interval sampling)	S5A or A22U1
LCMC	Change main time bit C (HMTC)	U16	LIA	X1 Atten	U401
LCOV	Clock overload	U16	HIFA	Internal function bit A	From S3 or A11U10
HCRA	Combined range bit A	S4 or A11U11	HIFB	Internal function bit B	From S3 or A11U10
HCRB	Combined range bit B	S4 or A11U11	LIG	X1 Gain	U401
HCRC	Combined range bit C	S4 or A11U11	HINP	Input polarity	U22
LCSO	Clear stored outputs	U16	LINS	Input short	U401
LCTC	Clear time counter	U16	LIOG	X10 Gain	U401
HDCA	Data Counter bit A	U1	HMTA	Main time bit A	U14
LIR	X1 Atten reed	U401	HMTB	Main time bit B	U11
HIRA	Internal range bit A	U21	HMTC	Main time bit C	U11
HIRB	Internal range bit B	U21	LOIA	X0.01 Atten	U401
HIRC	Internal range bit C	U21	LOIR	X0.01 Atten, reed	U401
LLEC	Leakage control	U401	LOMR	Ohms ref select	U401
HMA	Machine state bit A	Next state outputs from	LOTE	Output enable to decoder	U9
HMB	Machine state bit B	ROM U9, present state	HOVP	Overload protection	U401
HMC	Machine state bit C	outputs from state	HOVL	Overload	U22
HMD	Machine state bit D	storage U7, U17.	LPRF	+ Ref select	U401
HMDA	Main time bit A delayed	From Sample/Hold option	LPRG	Preset range	U16
HMDB	Main time bit B delayed	if not installed these signals	HRAP	Ratio polarity	U22 or Ratio option
HMDC	Main time bit C delayed	are same as HMTA, B, C.	HSA	Display scan A	A3U2
HME	Machine state bit E	(See HMA)	HSB	Display scan B	A3U2
HMF	Machine state bit F	(See HMA)	HSC	Display scan C	A3U2
HMG	Machine state bit G	(See HMA)	HSCK	State clock	U4
LMNC	Manual button normally closed contact	S5B	LSCK	State clock	U4
LMNO	Manual button normally open contact	S5B	LSHC	Select ÷ 100,000 counts	U6
LMOT	Memory output	U9	LSHC	Select ÷ 100,000 counts	U6
HMQA	Machine qualifier selection bit A	U10	LSPL	Store polarity	U16
HMQB	Machine qualifier selection bit B	U10	HSSA	Sample rate switch bit A	S5A
HMQC	Machine qualifier selection bit C	U10	HSSB	Sample rate switch bit B	S5B
HMQD	Machine qualifier selection bit D	U10	HSSC	Sample rate switch bit C	S5C
HMQD	Machine qualifier selection bit D	U9	LTC1	Time count 1 (÷ 10,000 or ÷ 100,000)	Q1
HMQE	Machine qualifier selection bit E	U10	HTC2	Time count 2	U6
LMQE	Machine qualifier selection bit E	U9	HTC4	Time count 4	U12
LMRF	— Ref select	U401	HTC8	Time count 8	U12
HDCB	Data Counter bit B	U1	HTC16	Time count 16	U12
HDCC	Data Counter bit C	U1	HTC32	Time count 32	U12
HDCD	Data Counter bit D	U1	HTFE	Transfer enable	U9
HDFL	Data Flag	U20	LTXF	Transfer	U18
LDNR	Downrange	U16	LTON	Turn-on, low for approx. 100 ms after turn-on	Q3
HDPP	Display polarity	U22 or Ratio or S/H Option	LUPR	Uprange	U16
			HZDT	Zero detect	U23

H preceding mnemonic means HIGH is true;
L means LOW is true.



3490A-C-2937A

A1

-hp- Part No. 03490-66551

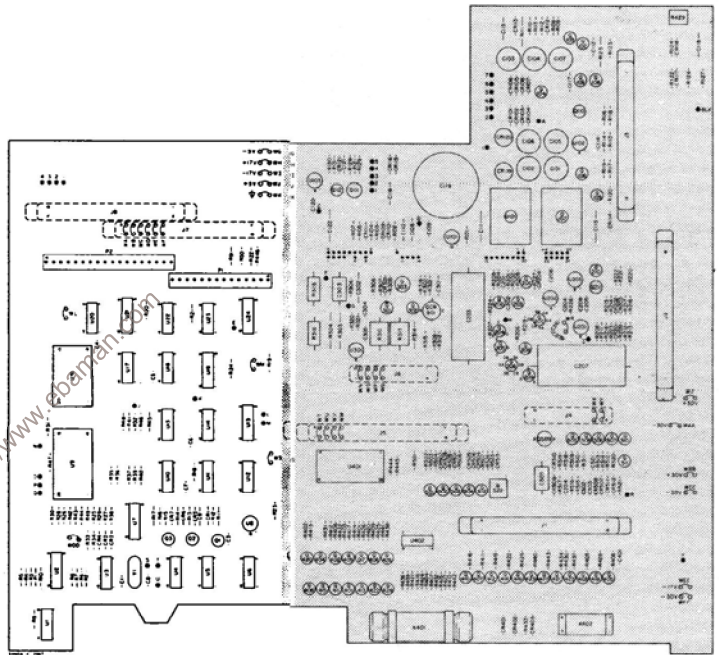

A1

-hp- Part No. 03490-66551

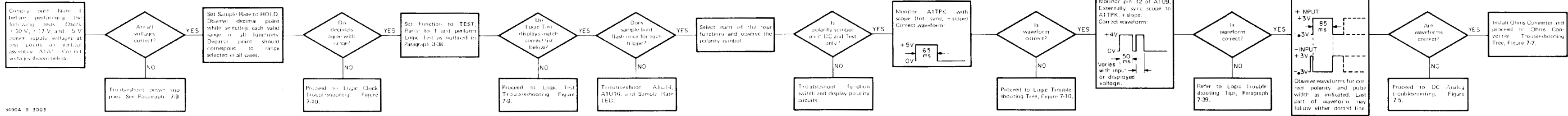

3490A □ 3003

NOTES

1. Before following this Troubleshooting Procedure, remove the Ohms Converter from its connector. It is not necessary to disconnect its input or output leads. If the Ohms Converter is left in its connector, a failure in the Logic Clock may damage the converter, or a failure in the converter may disable the clock and prevent valid troubleshooting.
2. A dc voltmeter, an oscilloscope and a dc standard are required for these checks. The Low terminal of the dc standard must be capable of floating at least 500 V above its chassis ground, since the oscilloscope ground (chassis) must be connected to the 3490A circuit element.
3. The time shown on waveforms is the correct time for instruments designed for 60 Hz line operation. For 50 Hz instruments, increase the time shown by 20 %.

Power Supply Voltages

A1A1 Test Point	Voltage
+17 V	+16.39 to +17.01 V
+30 V	+30.00 to +30.90 V
-5 V	+4.695 to +5.075 V
5 V	5.00 to 5.39 V
+17 V	16.96 to 17.65 V
-50 V	30.16 to 30.90 V

Correct list of Logic Test readings. Numbers, polarity symbol, and sequence must be exactly as shown, but readings may begin at any point in the list.

- + 080.024
- + 04.0024
- + 0.20024
- + 0.010024
- + 0.000024
- + 10.0024
- + 200.024
- + 4000.24
- + 80002.4
- + 6060.xx 01

<http://www.ebaman.com>

Figure 7-4. General Troubleshooting Tree.

7-11/7-12

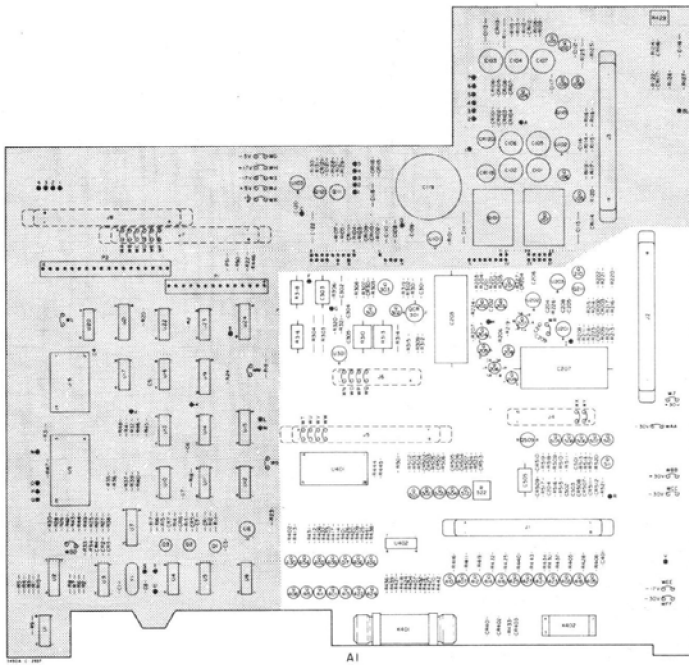

-hp Part No. 03490-66551

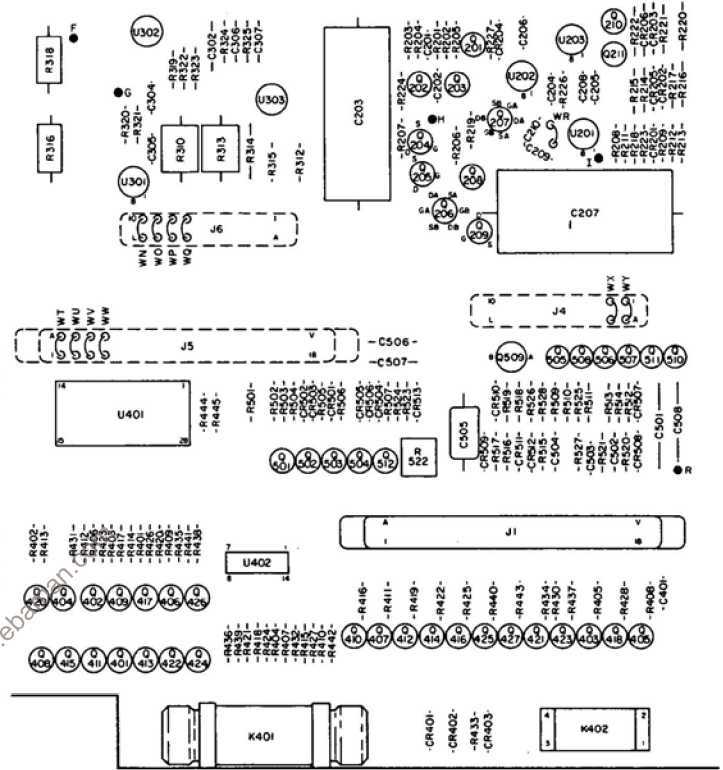

A1

-hp Part No. 03490-66551

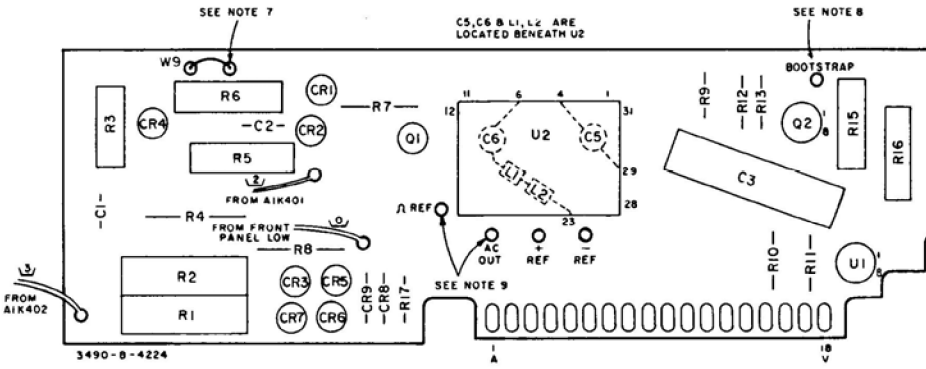

A2

hp Part No. 03490-66502 Rev. C

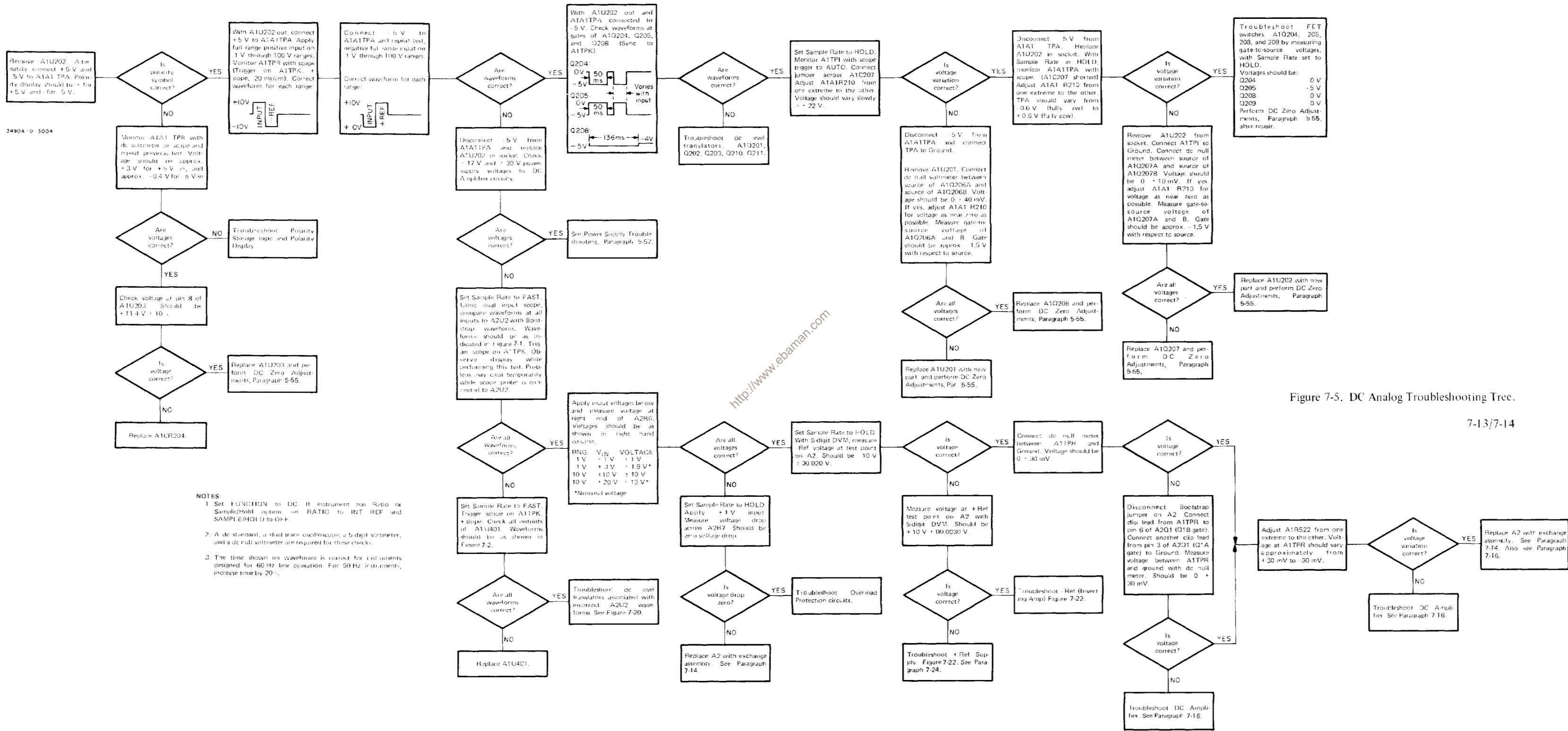

NOTES:

1. Set FUNCTION to DC. If instrument has Ratio or Sample/Hold option, set RATIO to INT REF and SAMPLE/HOLD to OFF.
2. A dc standard, a dual trace oscilloscope, a 5 digit voltmeter, and a dc null voltmeter are required for these checks.
3. The time shown on waveforms is correct for instruments designed for 60 Hz line operation. For 50 Hz instruments, increase time by 20%.

Figure 7-5. DC Analog Troubleshooting Tree.

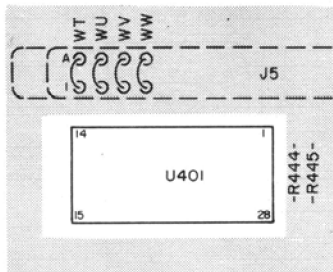

Frequency-Related Accuracy Problems

Frequency at which Specification is Exceeded	Range on which Error Occurs	Possible Cause
100 Hz (low frequency only)	All ranges 1 V and 100 V 10 V and 1000 V 100 V and 1000 V	R4A or R4B R4B or R27 R4C or R28 R1A, B or R3
20 kHz - 30 kHz (mid-band only)	All ranges 1 V and 100 V 10 V and 1000 V 100 V and 1000 V	C3 C3 or C25 C3 or C26 C2 or C5
100 kHz (high frequency only)	All ranges 1 V and 100 V 10 V and 1000 V 100 V and 1000 V	C3, R29A, B, or R32 C25 C26, C27, or C28 C2, C4, C5, or C6

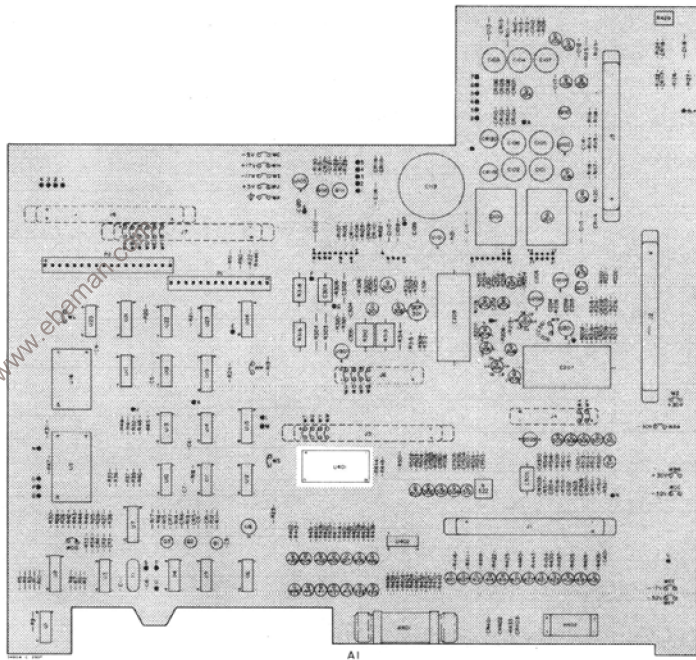

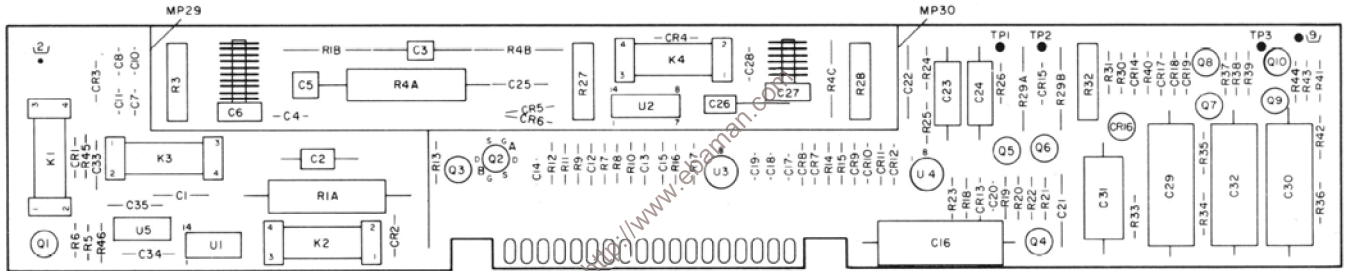

3490A-B-4223

A6

hp Part No. 03490-66506
Rev D

Set FUNCTION to AC. Apply full-range input at 100 Hz on each range. Monitor converter output at white wire. Should be +1 V ± 0.002 V for full-range input on each range.

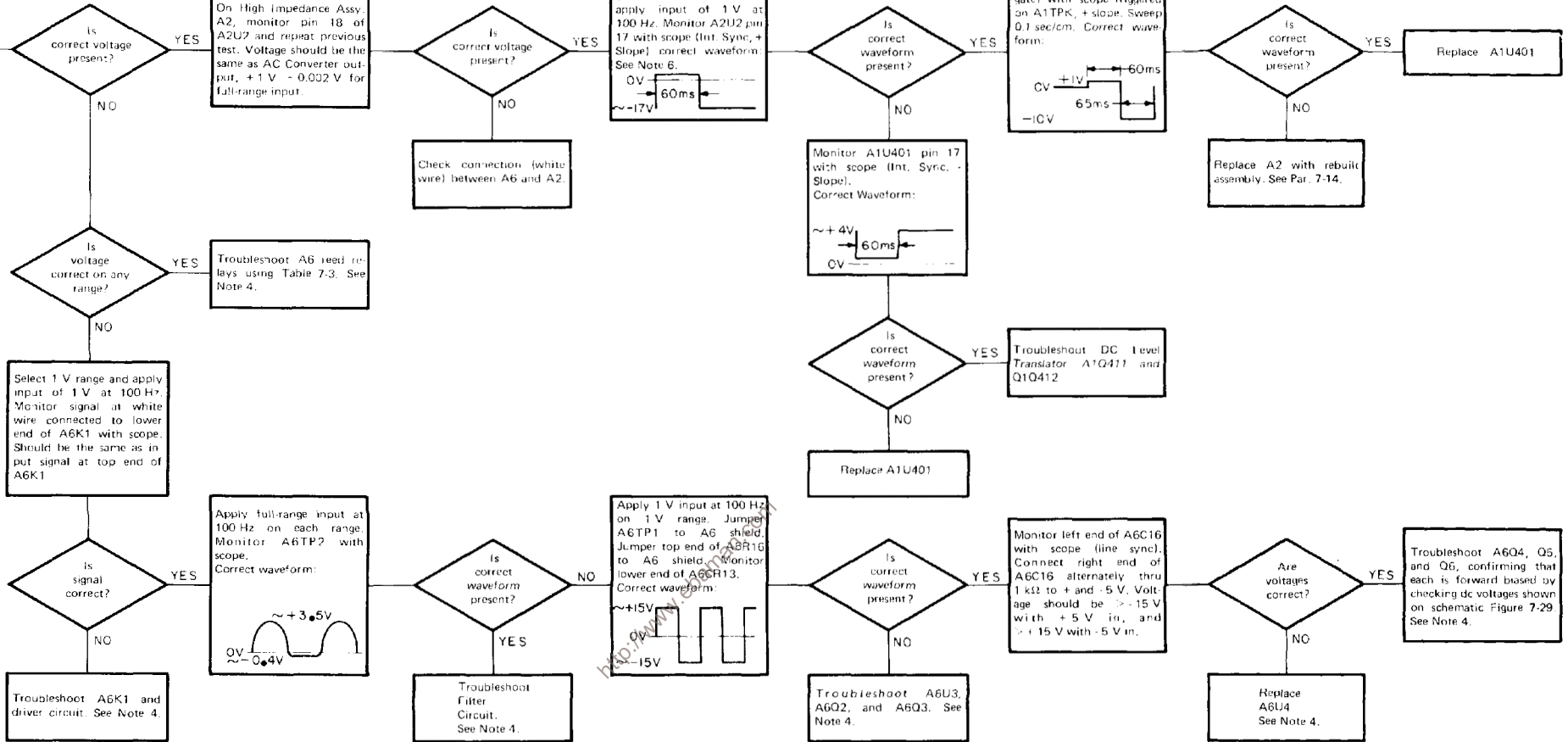
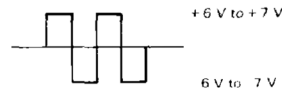

Figure 7-6. AC Converter Troubleshooting Tree.

NOTES:

1. DC voltmeter circuits, including logic, must be operating correctly before this procedure is attempted.
2. An ac calibrator, an oscilloscope, and a dc voltmeter are required for these checks.
3. The time shown on waveforms is correct for instruments designed for 60 Hz line operation. For 50 Hz instruments, increase time shown by 20%.
4. After repairing the AC Converter, check the overload protection circuits in the following manner:
 - a. Set 3490A FUNCTION to AC, RANGE to 1 V, SAMPLE RATE to FAST.
 - b. Apply input of 10 V at 100 Hz.

c. Monitor A6TP1 with scope. Correct waveform:



d. If waveform is not clipped at proper levels, troubleshoot A6CR5-12, A6R14, 15.

e. Measure voltage at A6TP3 with scope. Should be +2 V to +2.5 V.

f. If voltage is not correct, troubleshoot A6CR16-19, A6R40.

5. If the AC Converter operation is out of specifications only at certain frequencies, refer to the table of Frequency-Related Accuracy Problems.

6. Pin 18 indicates the reverse waveform.

SEE NOTE 7

C5, C6 & L1, L2 ARE
LOCATED BENEATH U2

SEE NOTE 8

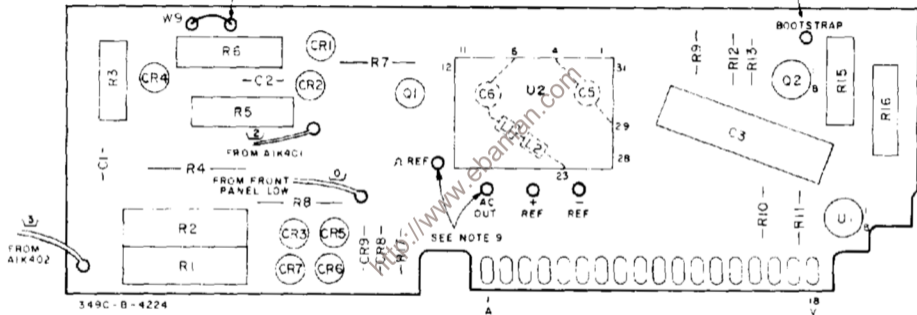

349C-B-4224

A2

hp Part No. 03490-66502 Rev. C

549CA-R 2979A

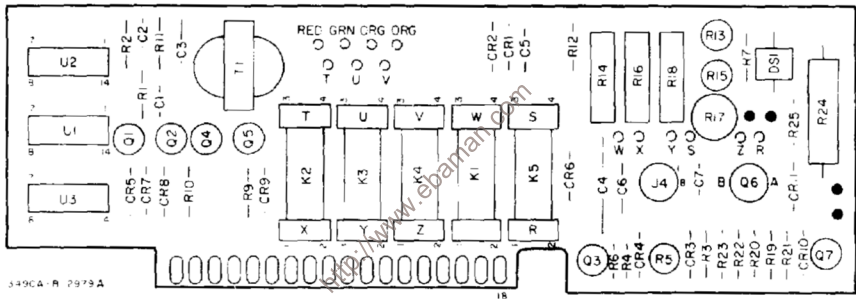

A7

hp Part No. 03490-66507

Rev. C

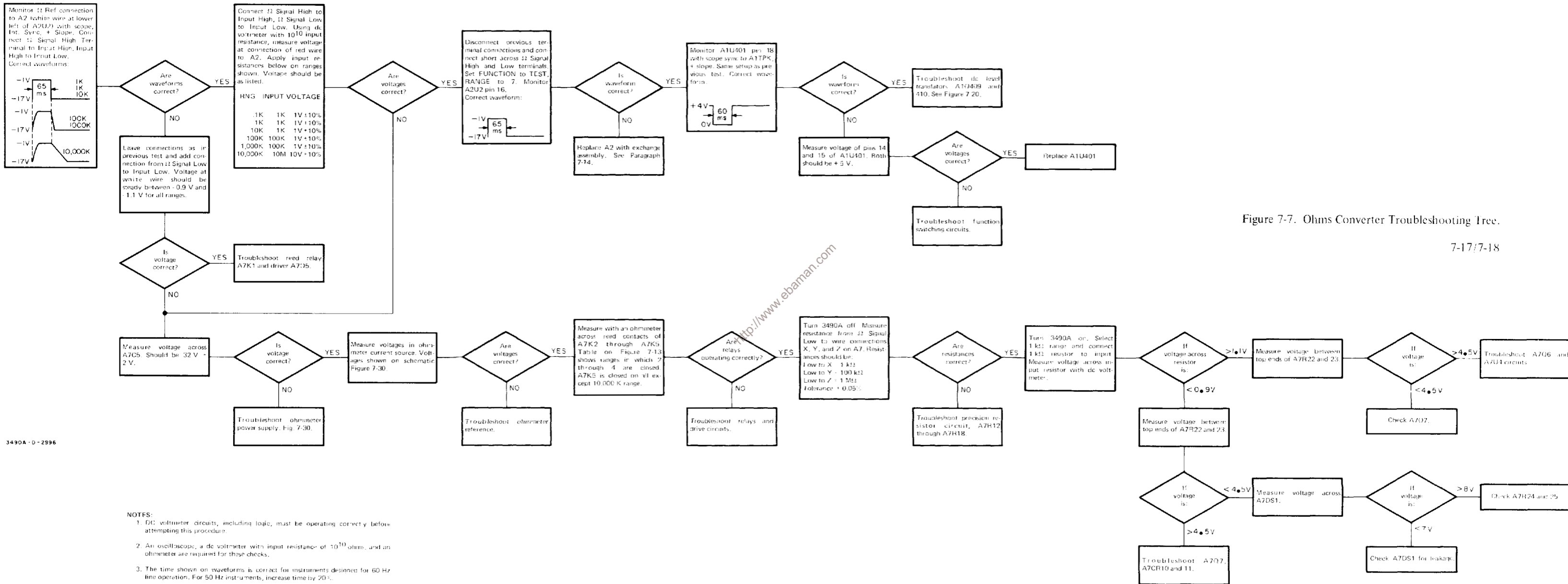
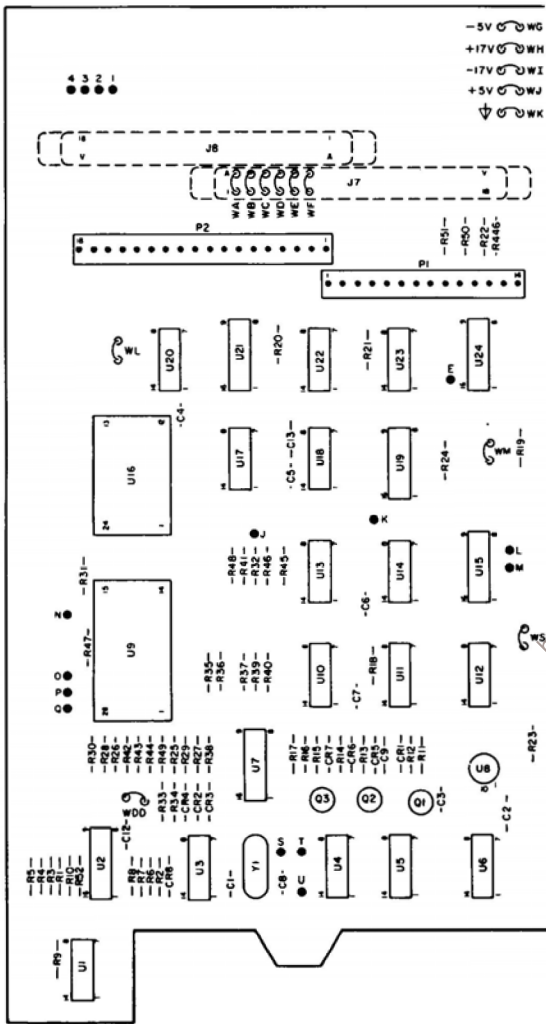

Figure 7-7. Ohms Converter Troubleshooting Tree.

7-17/7-18

NOTES:

1. DC voltmeter circuits, including logic, must be operating correctly before attempting this procedure.
2. An oscilloscope, a dc voltmeter with input resistance of 10¹⁰ ohms, and an ohmmeter are required for these checks.
3. The time shown on waveforms is correct for instruments designed for 60 Hz line operation. For 50 Hz instruments, increase time by 20%.



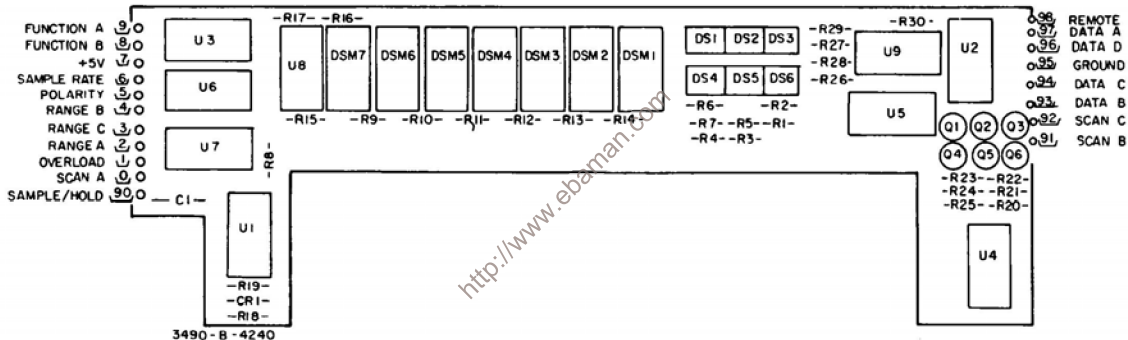

3490-B-4240

A3

hp Part No. 03490-66543

Monitor the scan signals at A1U2 as shown below. Scope on Int. Sync. + Slope. Correct waveforms: Scan C, Pin 8

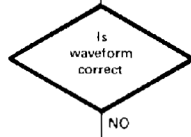
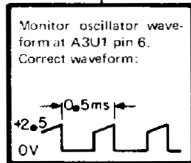
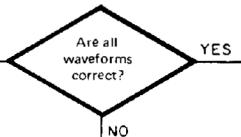
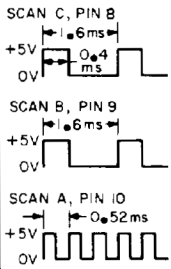

Replace A3U1

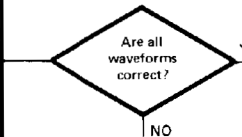
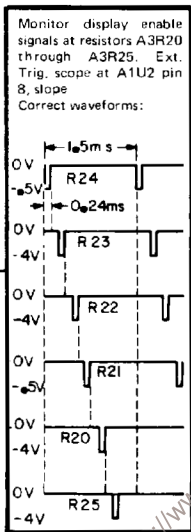

Replace A3U5

Troubleshoot display units DSM1 through DSM6 by substituting a known good unit for one which appears to be defective.

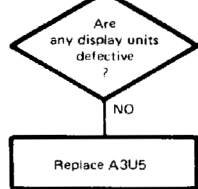

Replace defective display units.

NOTES:

1. If the 3490A has the special annunciator display, the assembly designation is A20. All A3 component designators also apply to the A20 assembly.
2. An oscilloscope is required for these checks.

Figure 7-8. Display Troubleshooting Tree.

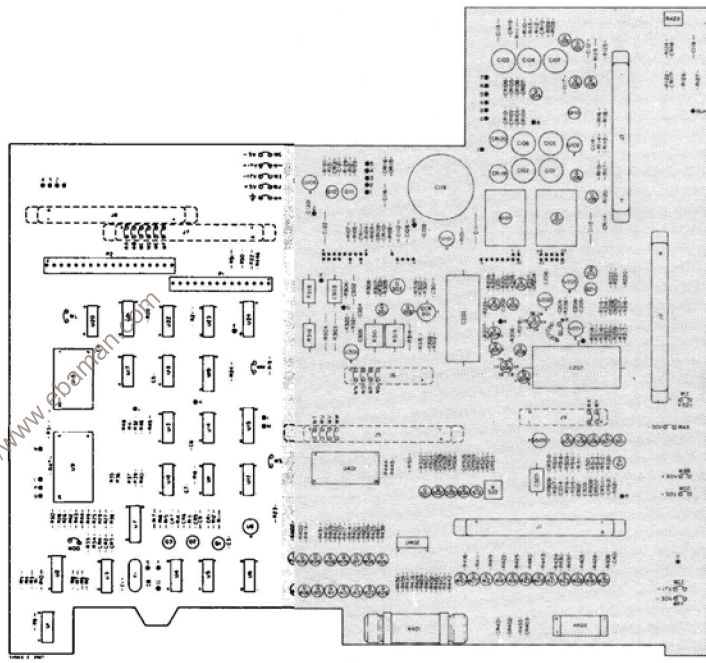
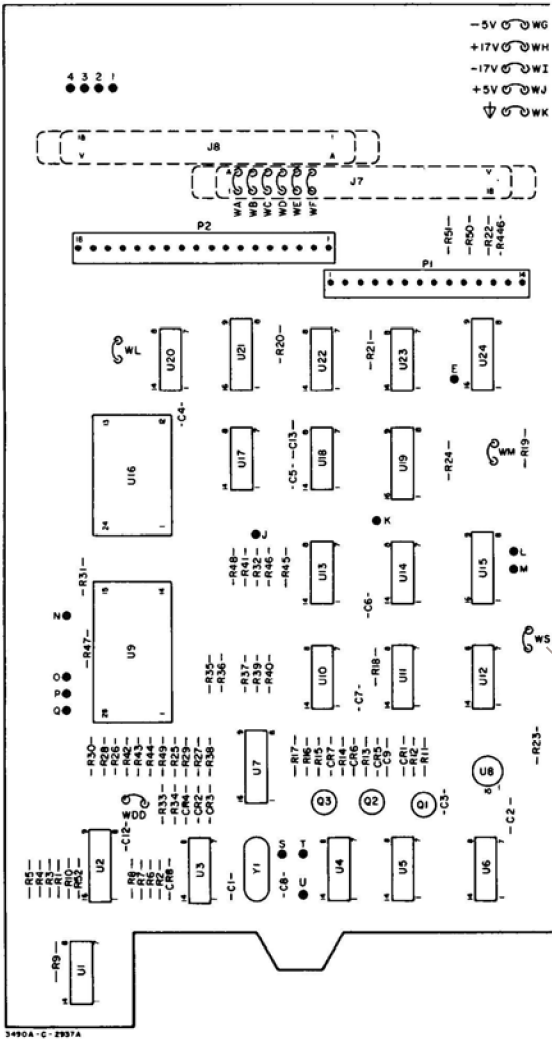

AI

-hp- Part No. 03490-66551

A1

-hp- Part No. 03490-66551

-5V WG
 +17V WH
 -17V WI
 +5V WJ
 WK

4 3 2 1

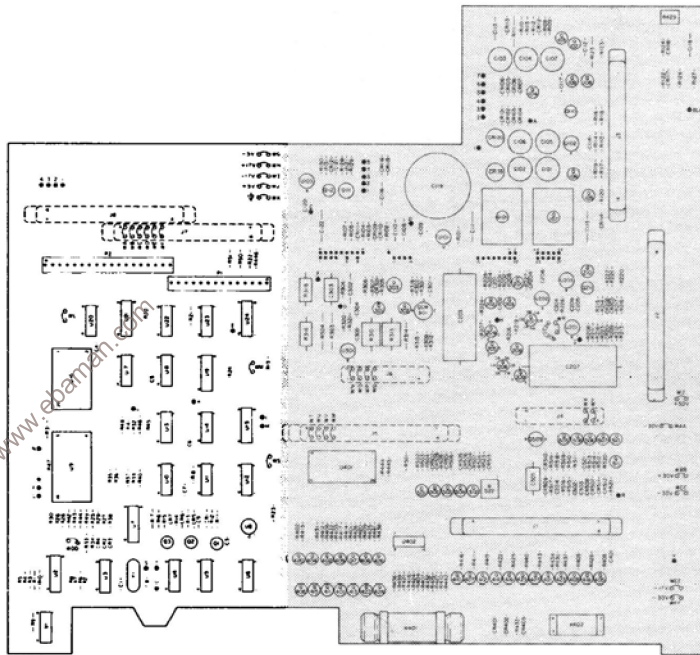
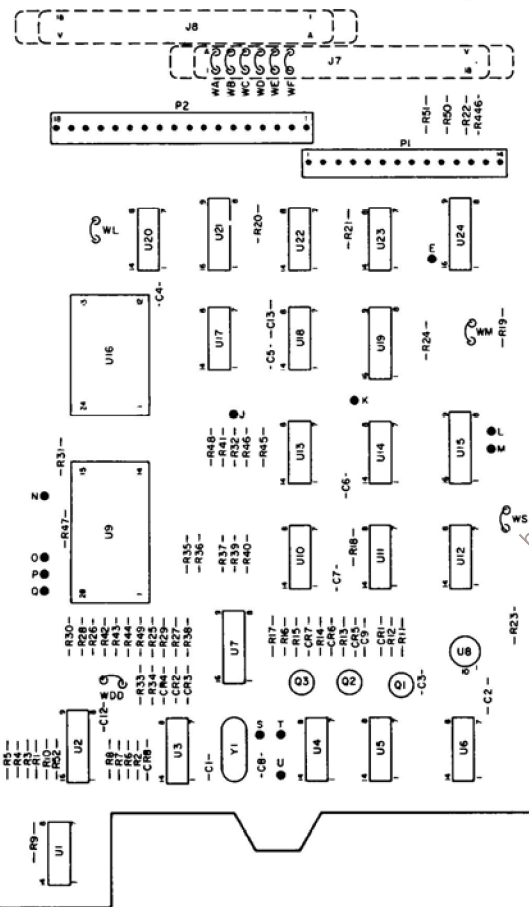

A1

-hp- Part No. 03490-66551

A1

-hp- Part No. 03490-66551

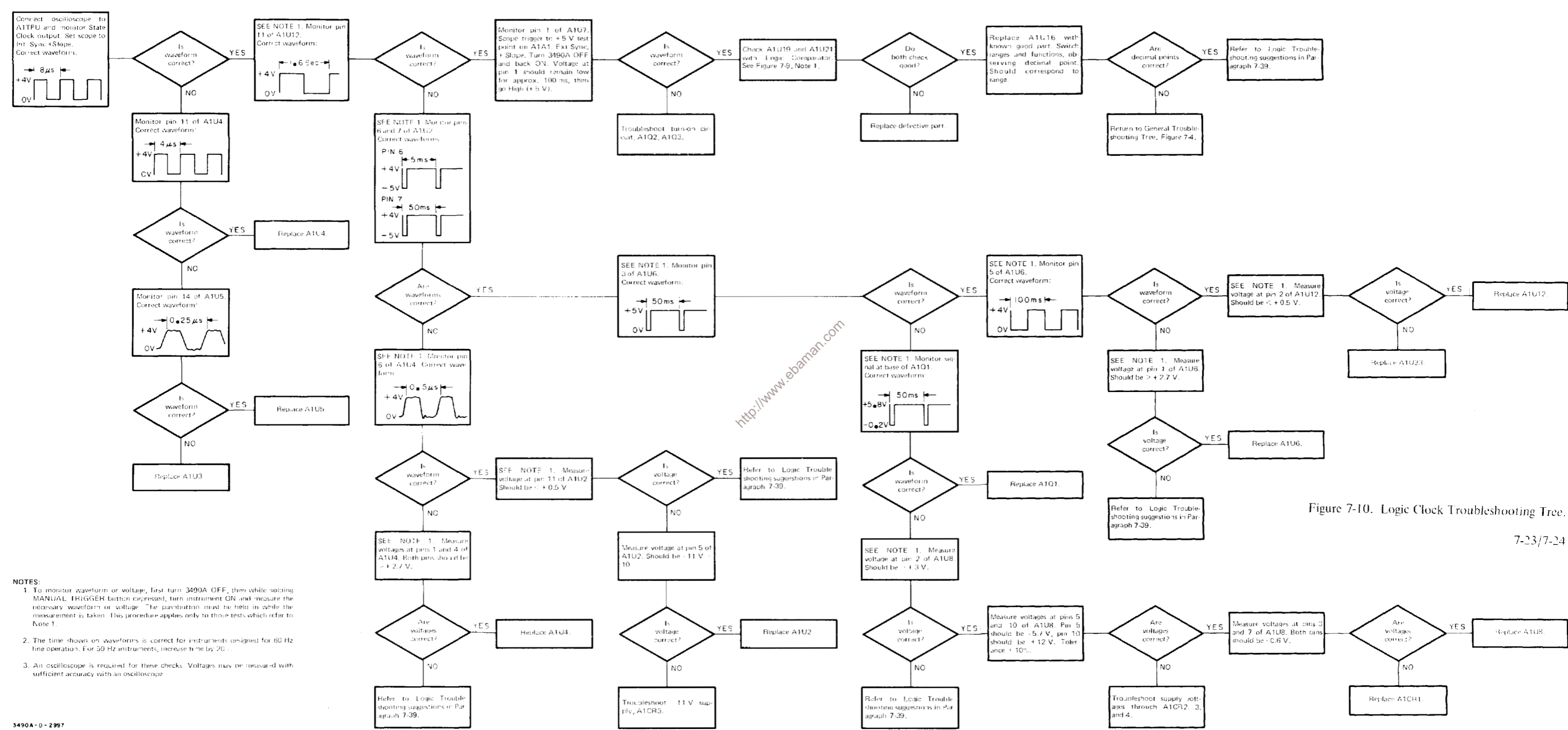
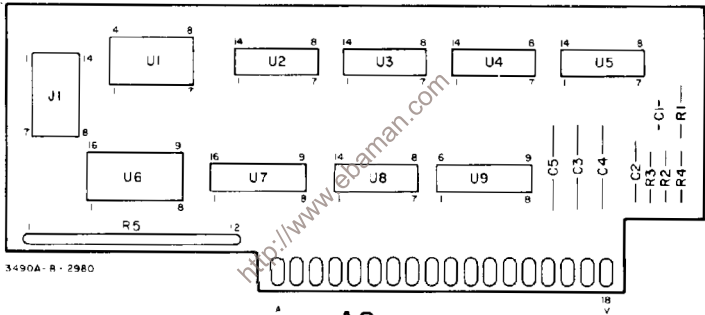

Figure 7-10. Logic Clock Troubleshooting Tree.

7-23/7-24

- NOTES:**
- To monitor waveform or voltage, first turn 3490A OFF, then while holding MANUAL TRIGGER button depressed, turn instrument ON and measure the necessary waveform or voltage. The pushbutton must be held in while the measurement is taken. This procedure applies only to those tests which refer to Note 1.
 - The time shown on waveforms is correct for instruments designed for 60 Hz line operation. For 50 Hz instruments, increase time by 20%.
 - An oscilloscope is required for these checks. Voltages may be measured with sufficient accuracy with an oscilloscope.



3490A-R-2980

hp Part No. 03490-66509

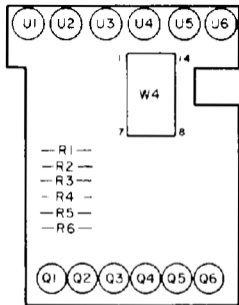

AI5A1

hp Part No. 03490-66515

3490A - B - 3000

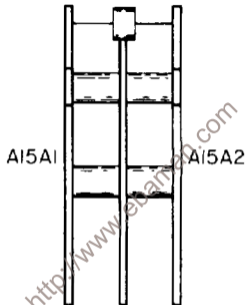

AI5

hp Part No. 03490-60306

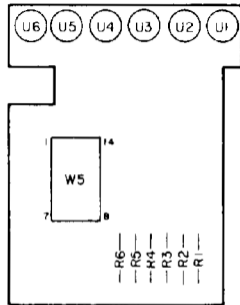

AI5A2

hp Part No. 03490-66516

U1-U6

OPTICAL ISOLATORS

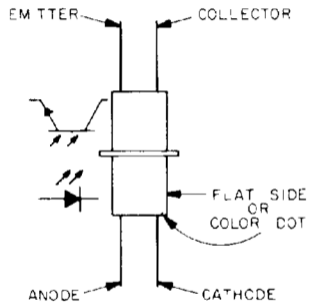

3490 B-3597

-hp- PART NO. 5080-9052

and

-hp- PART NO. 1990-0402

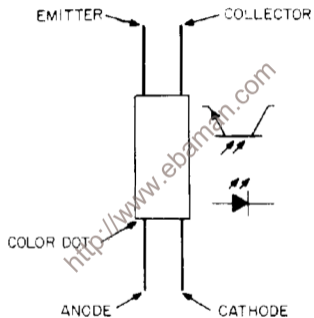

-hp- PART NO. 1990-0514

If an optical isolator is to be replaced, see Section VIII, Backdating, CHANGE NO. 9, Table 8-2 to determine correct Part No.

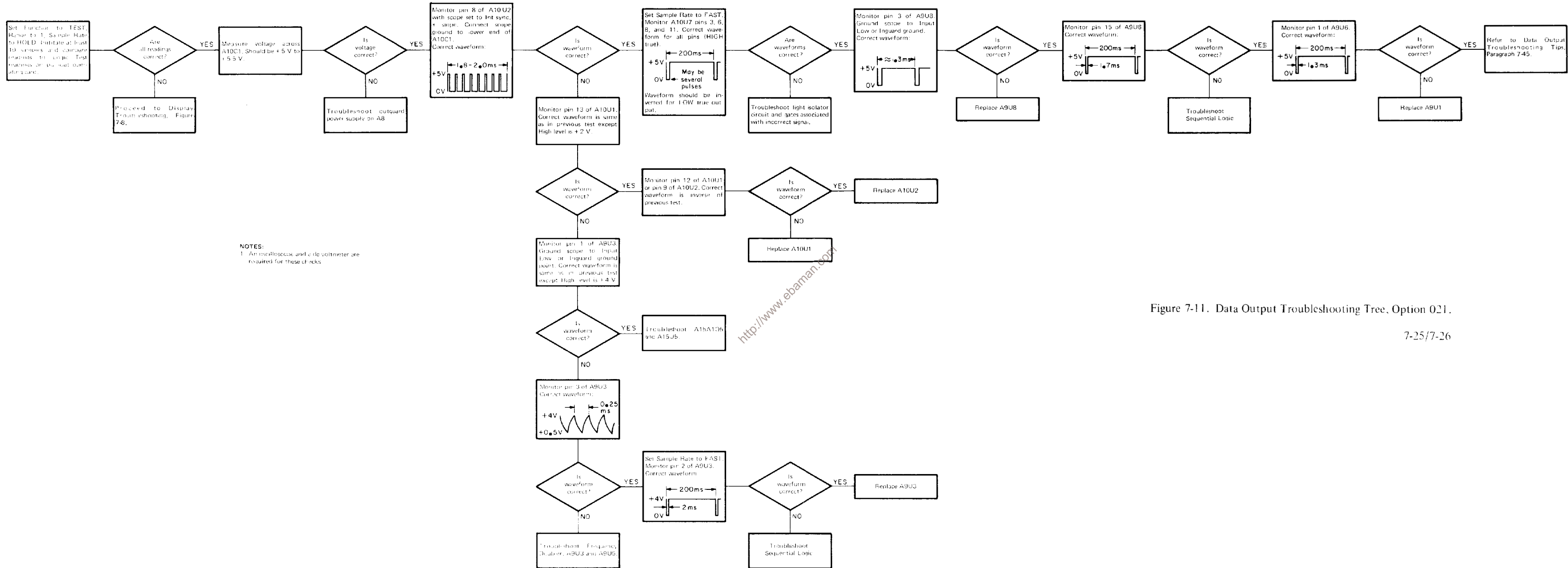

NOTES:
1. An oscilloscope, and a dc voltmeter are required for these checks.

Figure 7-11. Data Output Troubleshooting Tree, Option 021.

7-25/7-26

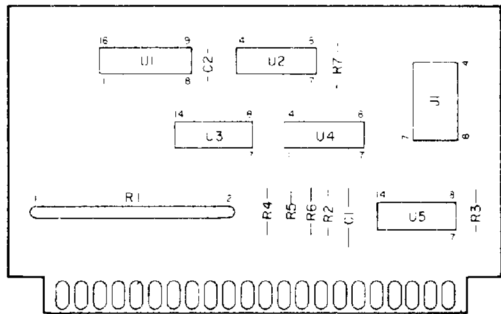

3490A-B-2986

AI2

hp Part No. 03490-66512

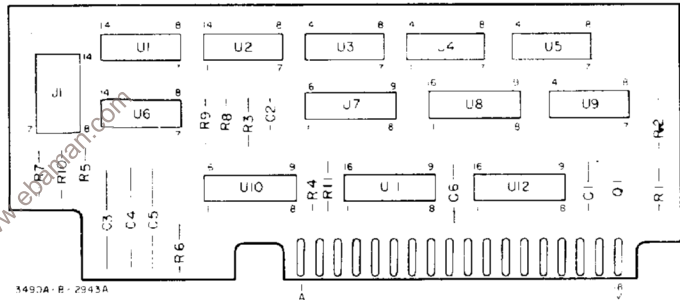

3490A-B-2943A

AI1

hp Part No. 03490-66511

Rev. C



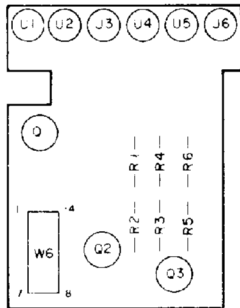

A17A1

hp Part No. 03490-66517

3490A-B-3001

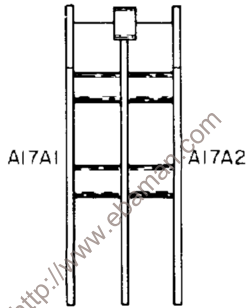

A17

hp Part No. 03490-60308

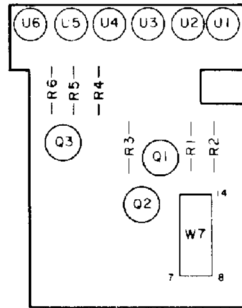

A17A2

hp Part No. 03490-66518

U1-U6

OPTICAL ISOLATORS

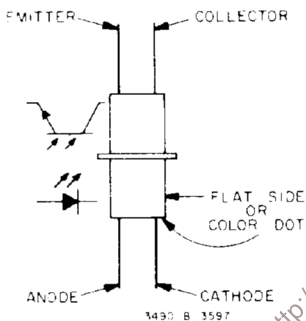

-hp- PART NO. 5080-9052
and
-hp- PART NO. 1990-0402

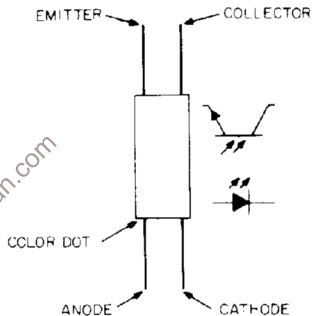

-hp- PART NO. 1990-0514

If an optical isolator is to be replaced, see Section VIII, Backdating, CHANGE NO. 9, Table 8-2 to determine correct Part No.

SEE NOTE 1

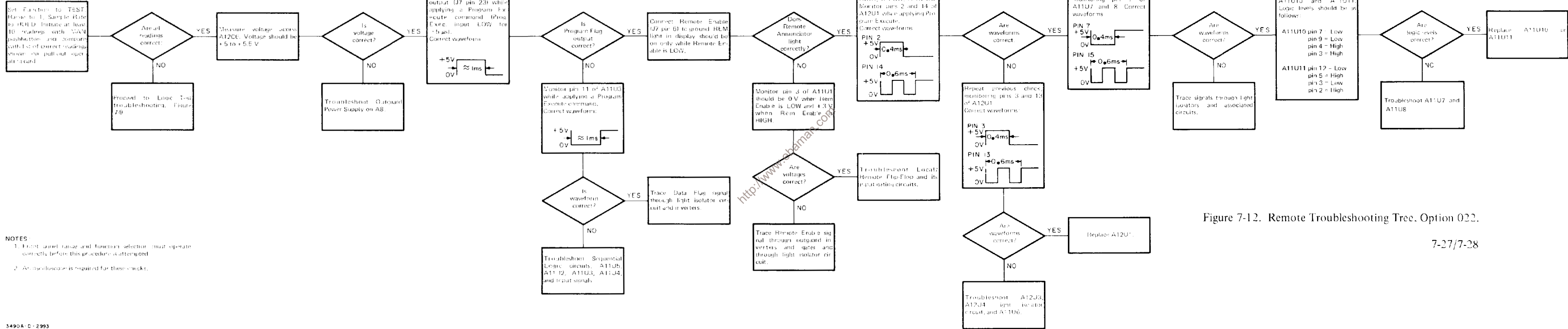

Figure 7-12. Remote Troubleshooting Tree, Option 022.

7-27/7-28

NOTES:

1. Front panel range and function selector must operate correctly before this procedure is attempted.
2. An oscilloscope is required for these checks.

START

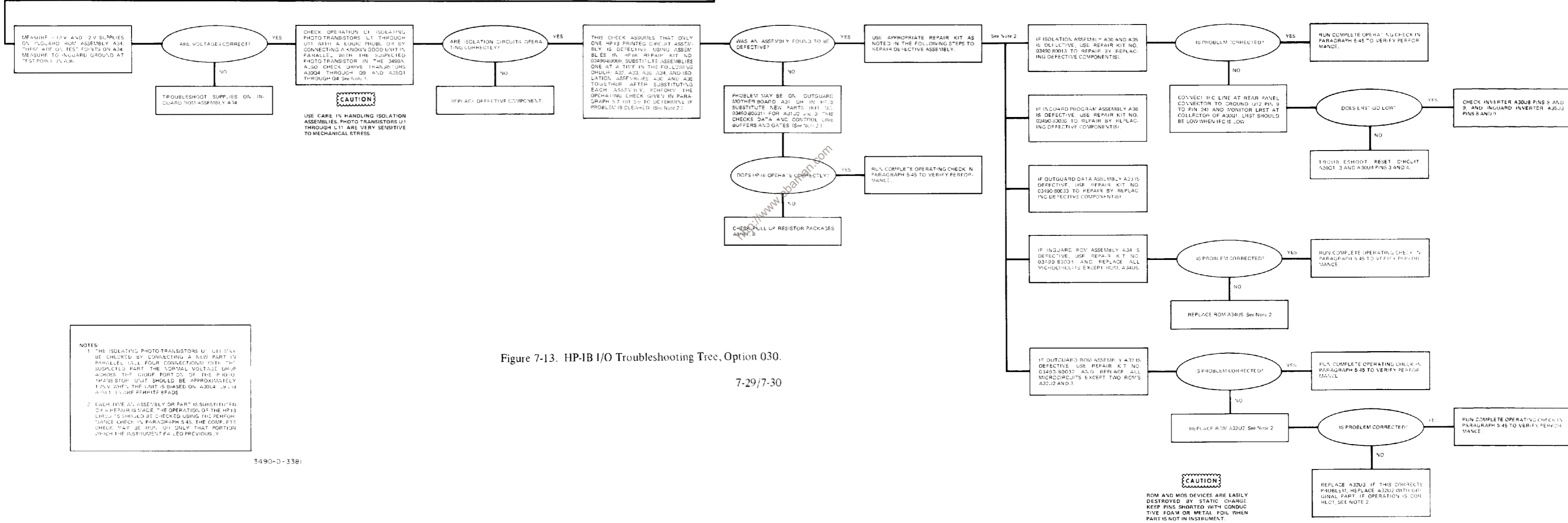
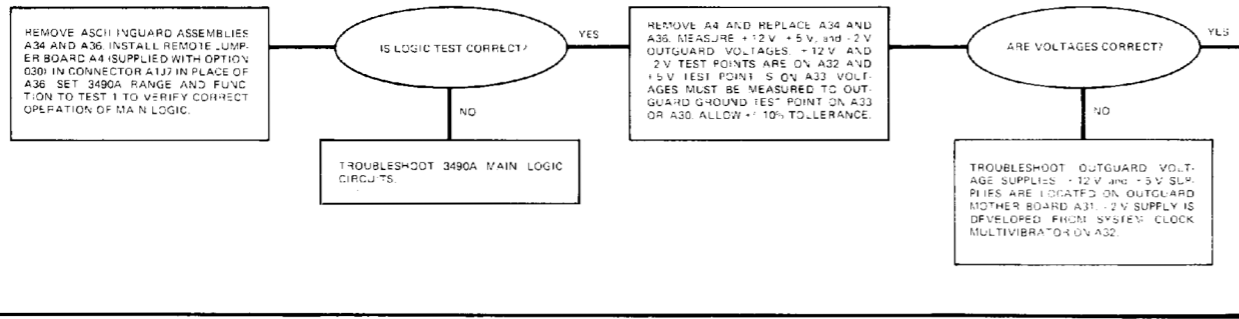

NOTES:

1. THE ISOLATING PHOTO TRANSISTORS U1 THROUGH U11 MAY BE CHECKED BY CONNECTING A NEW PART IN PARALLEL (ALL FOUR CONNECTIONS) WITH THE SUSPECTED PART. THE NORMAL VOLTAGE DROP ACROSS THE JUNCTION PORTION OF THE PHOTO TRANSISTOR UNIT SHOULD BE APPROXIMATELY 1.75 V WHEN THE UNIT IS BIASED ON A30L4 3 AND 4 WITH 1.5 MA FERRITE BEADS.

2. EACH TIME AN ASSEMBLY OR PART IS SUBSTITUTED OR A REPAIR IS MADE, THE OPERATION OF THE HP-13 CIRCUITS SHOULD BE CHECKED USING THE PERFORMANCE CHECK IN PARAGRAPH 5.45. THE COMPLETE CHECK MAY BE RUN, OR ONLY THAT PORTION WHICH THE INSTRUMENT FAILED PREVIOUSLY.

3490-D-3381

Figure 7-13. HP-IB I/O Troubleshooting Tree, Option 030.

7-29/7-30

CAUTION

ROM AND MOS DEVICES ARE EASILY DESTROYED BY STATIC CHARGE. KEEP PINS SHORTED WITH CONDUCTIVE FOAM OR METAL FOIL WHEN PART IS NOT IN INSTRUMENT.

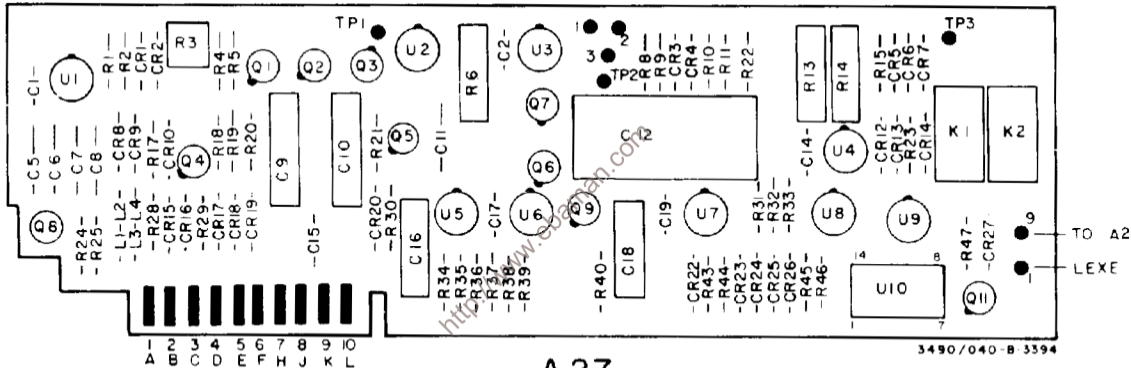

A27

hp Part No. 03490-66527

Rev. B

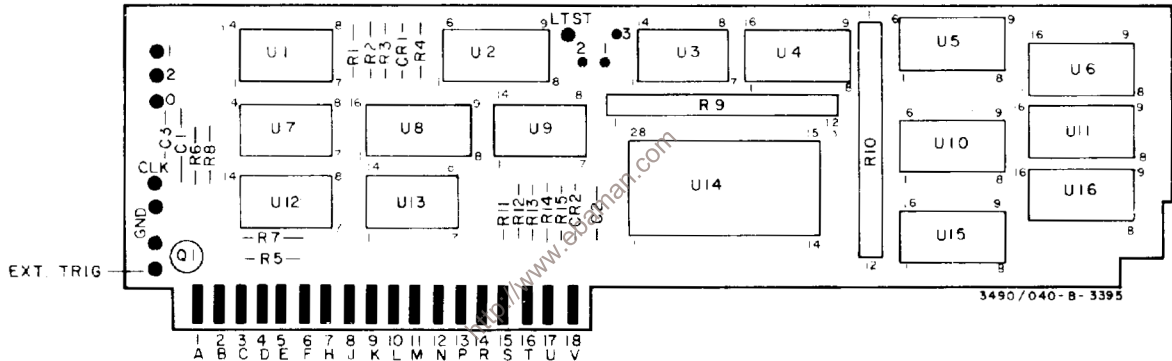

3490/040-B-3395

A 28

hp Part No. 03490-66528

Rev. C

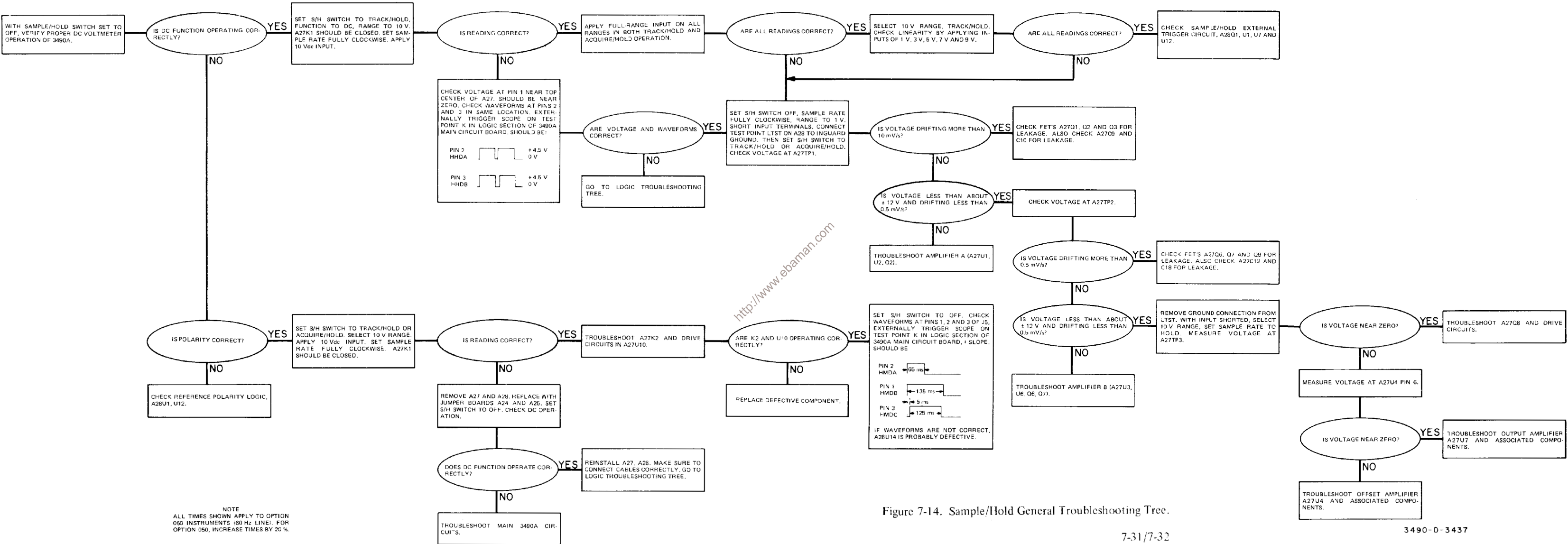
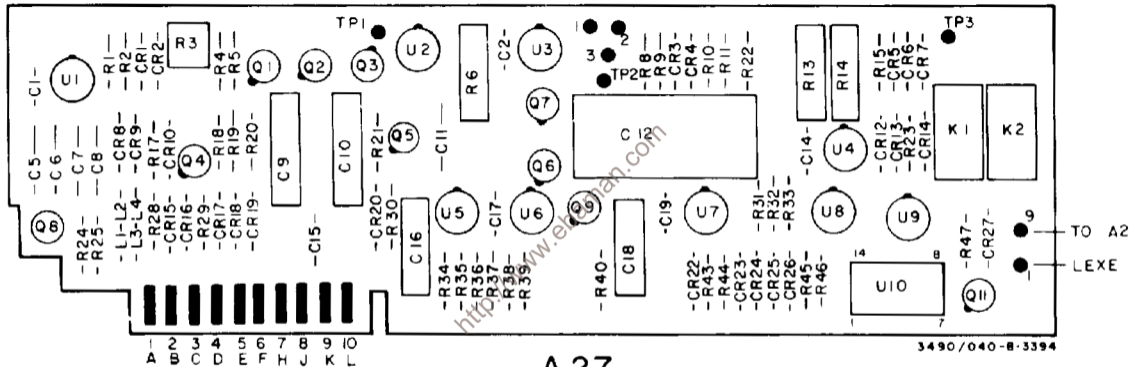

Figure 7-14. Sample/Hold General Troubleshooting Tree.



A27

hp Part No. 03490-66527

Rev. B

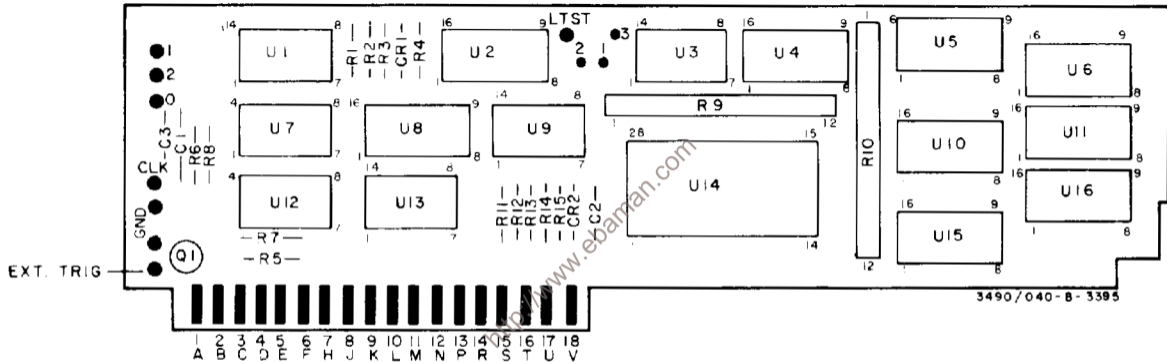

3490/040-B-3395

A28

hp Part No. 03490-66528

Rev. C

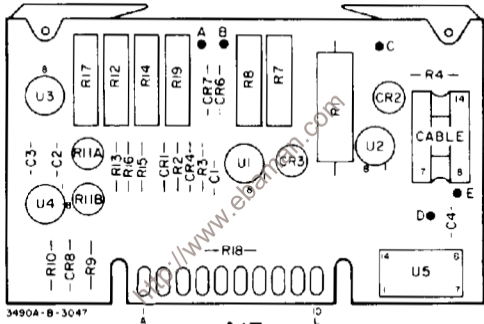

3490A-B-3047

A13

hp Part No. 03490-66513

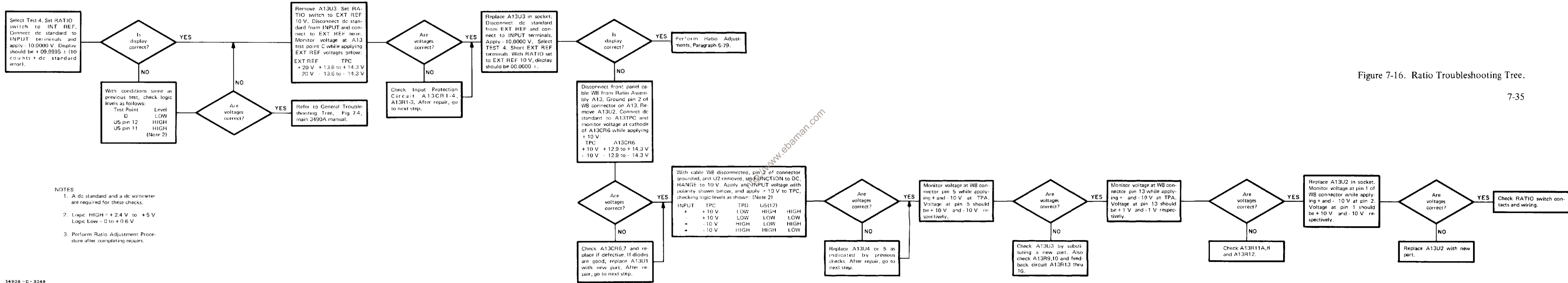

Figure 7-16. Ratio Troubleshooting Tree.

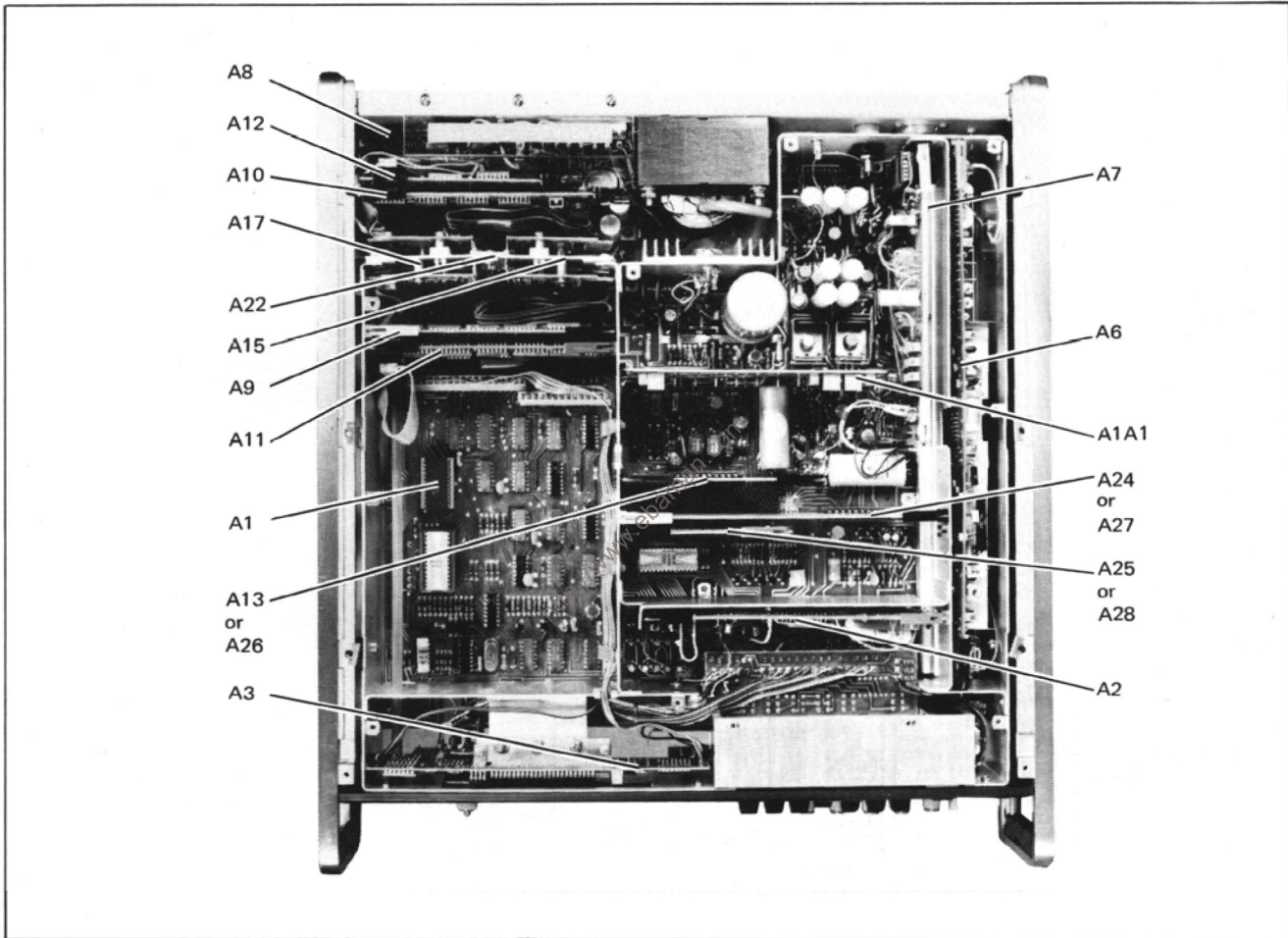

Figure 7-17. Location of Assemblies.

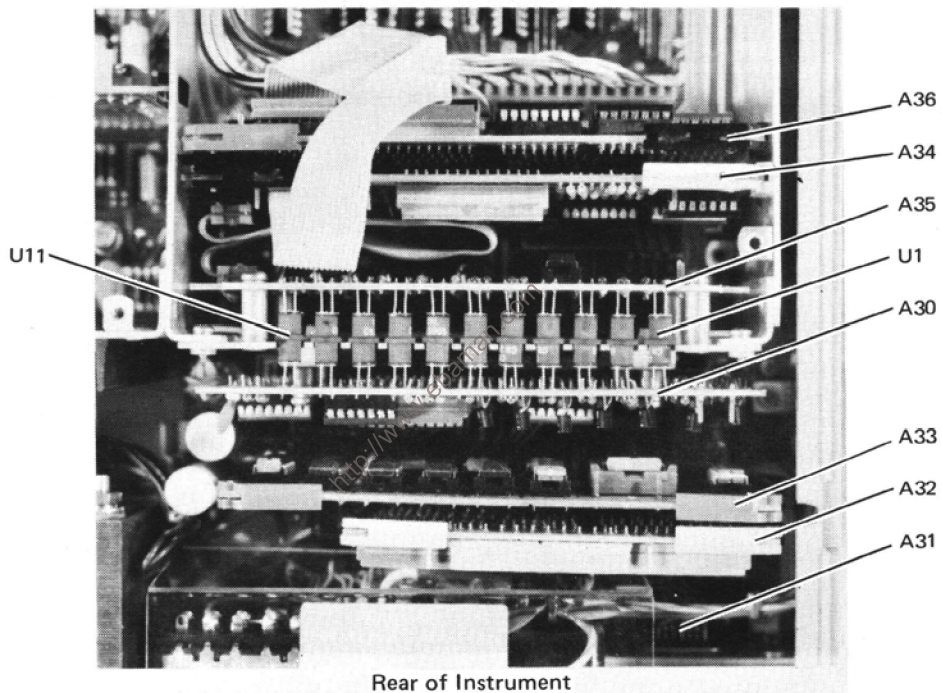

Figure 7-17. Location of Assemblies.

Assembly	Description	Figure No.
A1	Main Circuit Assembly	7-20 7-21 7-22 7-23 7-24 7-25 7-26
A2	High Impedance Assembly	7-20
A3	Display Assembly	7-27
A4	Remote Jumper Board	none
A5	Range Switch Assembly	7-28
A6	AC Converter Assembly	7-29
A7	Ohms Converter Assembly	7-30
A8	Outguard Power Supply	7-26
A9	Inguard Data Output Assembly	7-32
A10	Outguard Data Output Assembly	7-32
A11	Inguard Remote Assembly	7-33
A12	Outguard Remote Assembly	7-33
A13	Ratio Reference Assembly	7-22
A15	Data Output Isolation Assembly	7-32
A17	Remote Isolation Assembly	7-33
A22	Trigger Isolation Assembly	7-31
A24	Sample/Hold Analog Jumper Board	none
A25	Sample/Hold Logic Jumper Board	none
A26	Ratio Jumper Board	none
A27	Sample/Hold Analog Assembly	7-34
A28	Sample/Hold Logic Assembly	7-35
A29	Outguard Sample/Hold Power Supply	7-31
A30	HP-IB Outguard Isolation Assembly	7-38
A31	HP-IB Outguard Mother Board	7-40
A32	Outguard ROM Assembly	7-39
A33	Outguard Data Assembly	7-39
A34	HP-IB Inguard Isolation Assembly	7-37
A35	Inguard Program Assembly	7-38
A36	Sample/Hold Trigger Gate Assembly	7-37
A37	Sample/Hold Trigger Gate Assembly	7-31

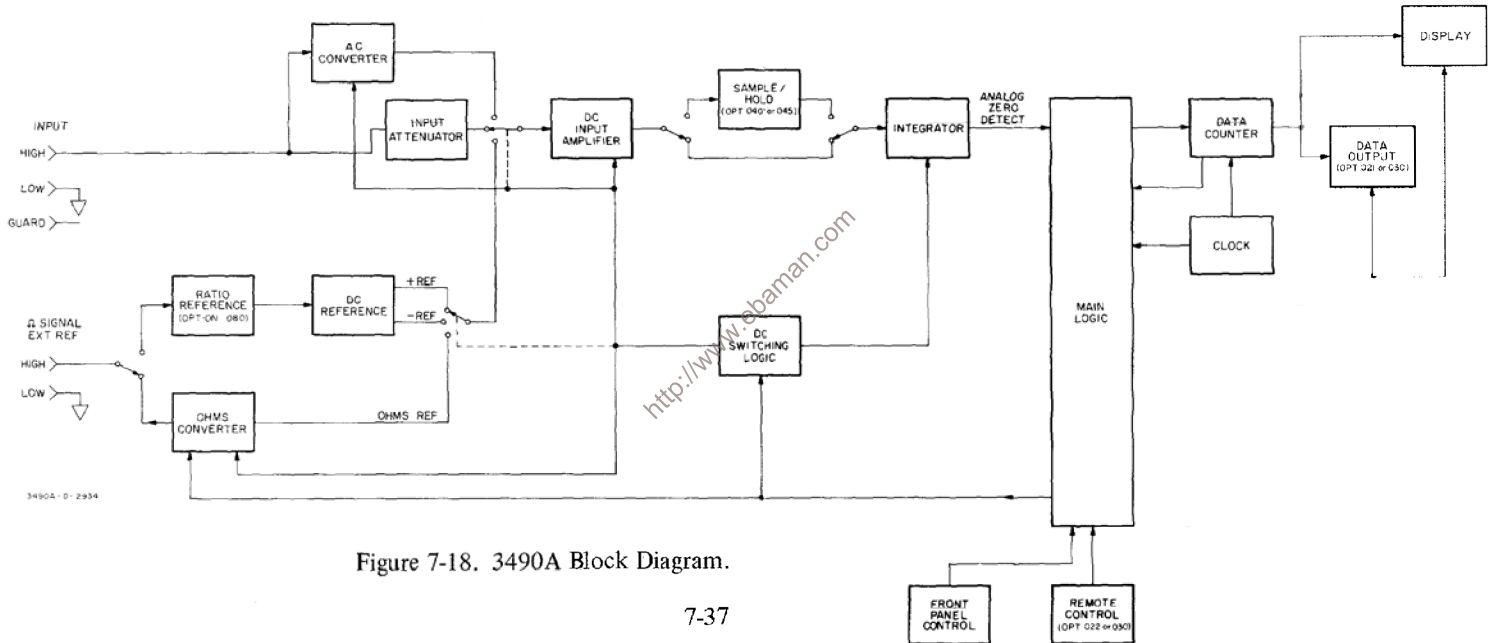
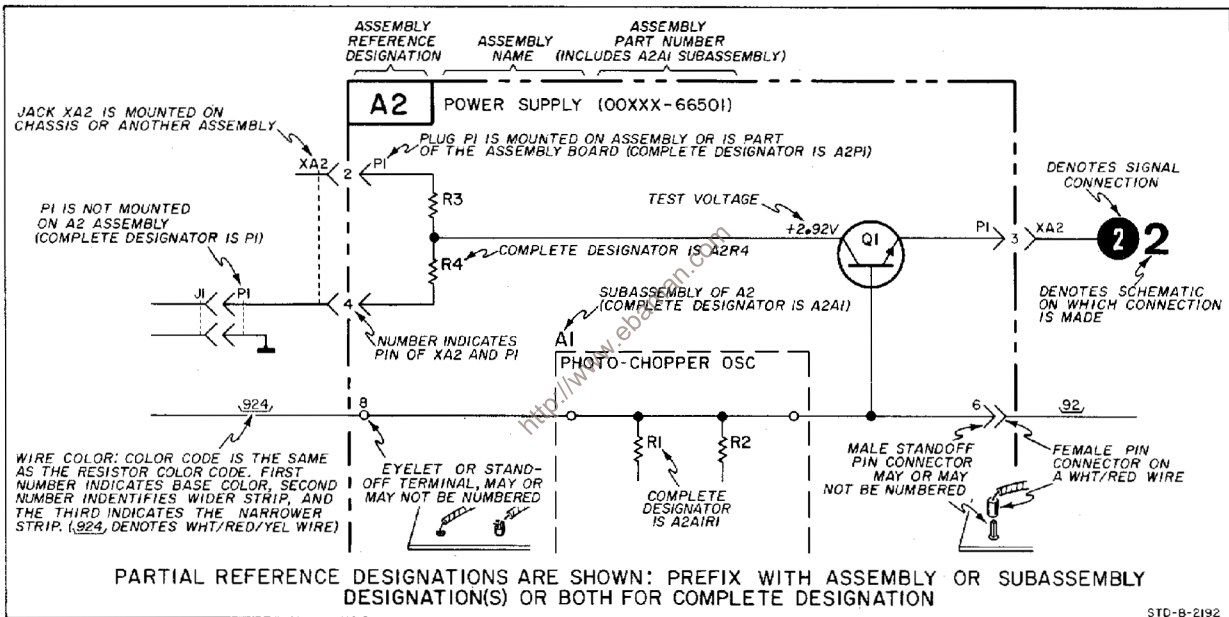

Figure 7-18. 3490A Block Diagram.

REFERENCE DESIGNATIONS



STD-B-2192

Figure 7-19. Reference Designations.

- R402-
- R413-
- R431-
- R412-
- R406-
- R429-
- R403-
- R417-
- R414-
- R401-
- R426-
- R430-
- R409-
- R435-
- R441-
- R436-

- 408
- 415
- 411
- 401
- 413
- 422
- 424

- R435-
- R439-
- R421-
- R418-
- R404-
- R407-
- R423-
- R432-
- R410-
- R442-

- 410
- 407
- 414
- 416
- 425
- 424
- 427
- 421
- 434
- 430
- 433
- 403
- 418
- 406

- R416-
- R411-
- R419-
- R422-
- R425-
- R440-
- R443-
- R434-
- R430-
- R437-
- R405-
- R428-
- R408-
- C401-

- CR401-
- CR402-
- R433-
- CR403-

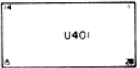
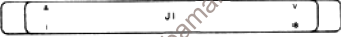
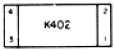

- R444-
- R445-

- R501-
- R502-
- R503-
- R504-
- CR502-
- CR503-
- R508-
- CR501-
- R506-
- CR506-
- CR506-
- CR504-
- R507-
- R524-
- R523-
- CR513-

- 501
- 502
- 503
- 504
- 512
- 522



- CR509-
- R517-
- R516-
- R519-
- R518-
- CR512-
- R526-
- R515-
- R528-
- C504-
- R509-
- R510-
- R527-
- C503-
- R521-
- R513-
- R514-
- R520-
- R512-
- CR508-
- CR507-

- C501-
- C508-

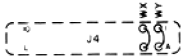

- 509
- 505
- 508
- 506
- 507
- 511
- 510

- +30V WBB
- 30V WCC

- 17V WEE
- 30V WFF
- C403-

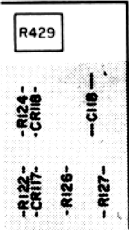

- R124-
- CR118-
- R122-
- CR117-
- R126-
- R127-
- C118-

AI
-hp- Part No. 03490-66551

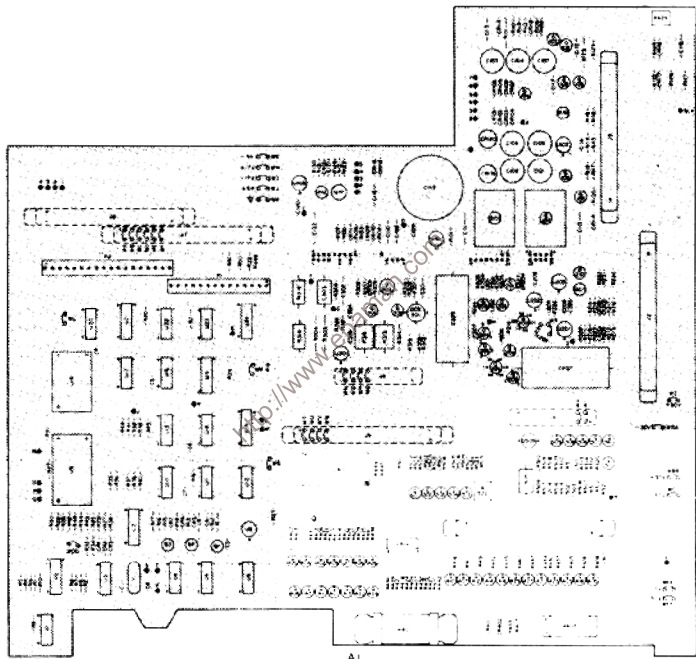

A1

-hp- Part No. 03490-66551

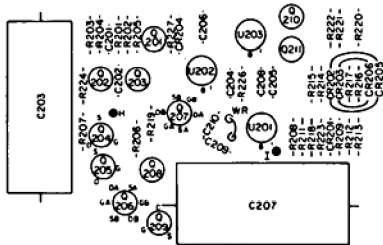

AI

hp Part No. 03490-66501

Rev E

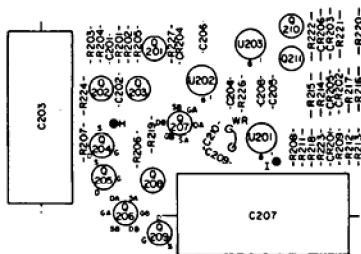

AI

hp Part No. 03490-66501

Rev F

and

AI

hp Part No. 03490-66541

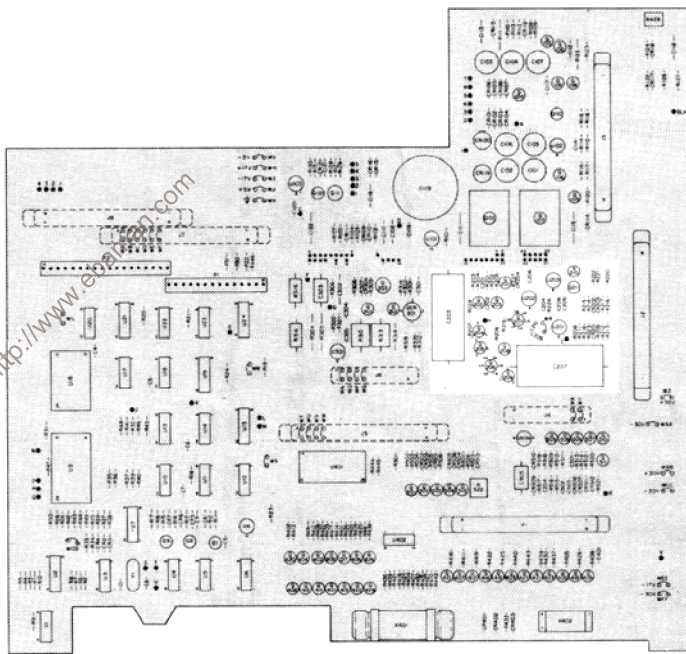

-hp- Part No. 03490-66551

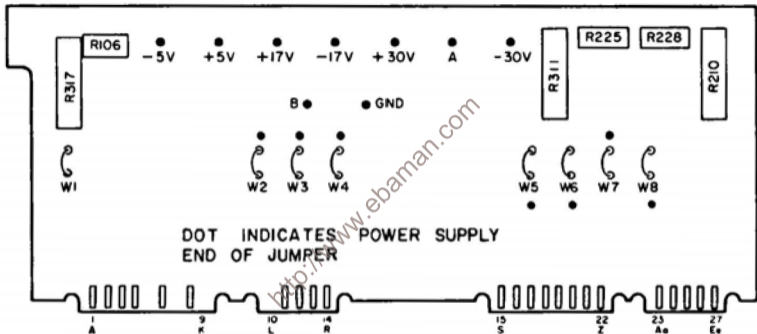

DOT INDICATES POWER SUPPLY
END OF JUMPER

AIAI

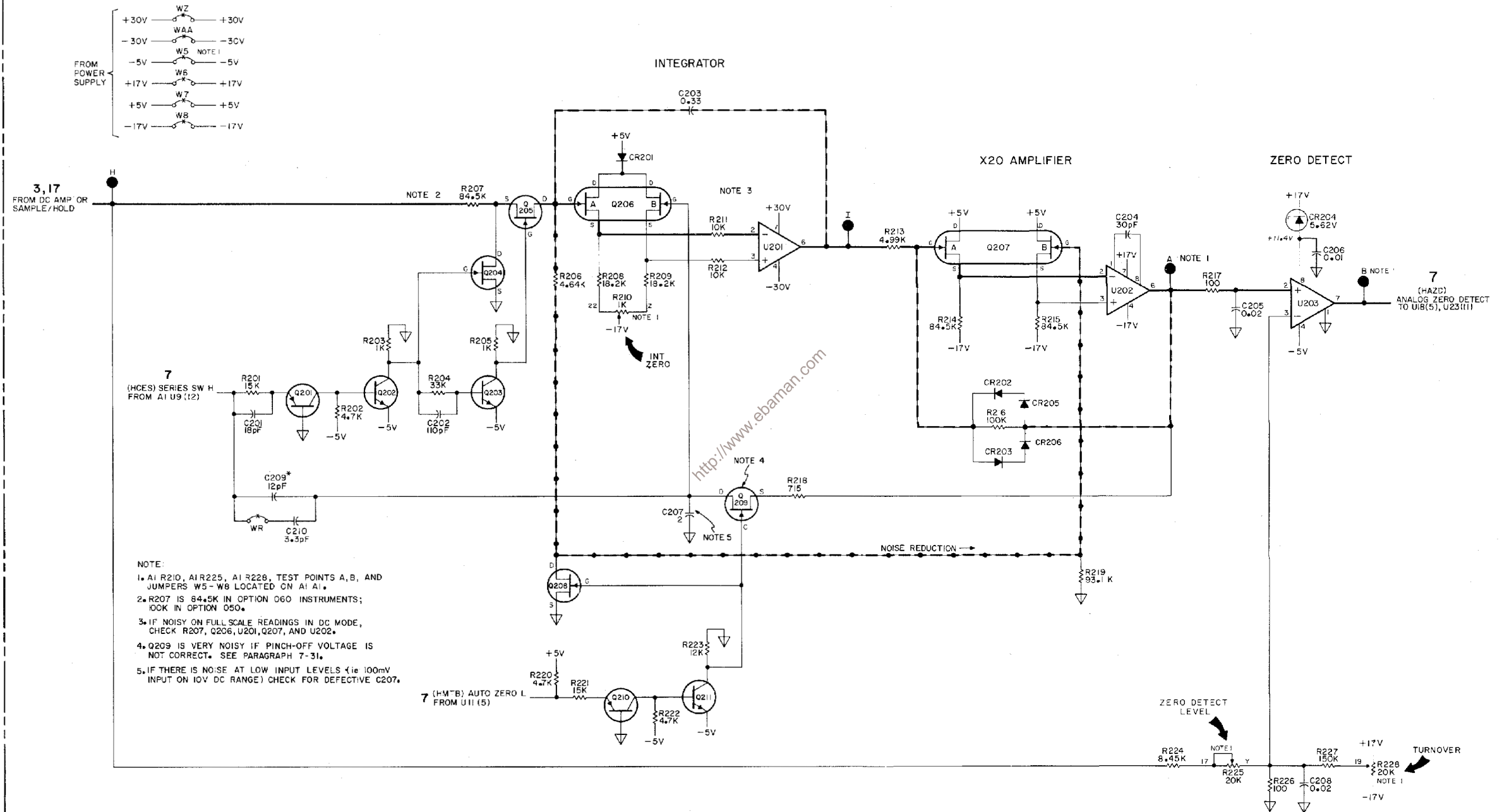

- NOTE:**
1. A1 R210, A1R225, A1 R228, TEST POINTS A, B, AND JUMPERS W5 - W8 LOCATED ON A1 A1.
 2. R207 IS 84.5K IN OPTION 060 INSTRUMENTS; 100K IN OPTION 050.
 3. IF NOISY ON FULL SCALE READINGS IN DC MODE, CHECK R207, Q206, U201, Q207, AND U202.
 4. Q209 IS VERY NOISY IF PINCH-OFF VOLTAGE IS NOT CORRECT. SEE PARAGRAPH 7-31.
 5. IF THERE IS NOISE AT LOW INPUT LEVELS (ie 100mV INPUT ON 10V DC RANGE) CHECK FOR DEFECTIVE C207.

Figure 7-21. Schematic Diagram, Integrator and Zero Detect Circuits, A1.

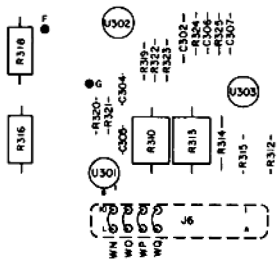

A1

-hp- Part No. 03490-66551

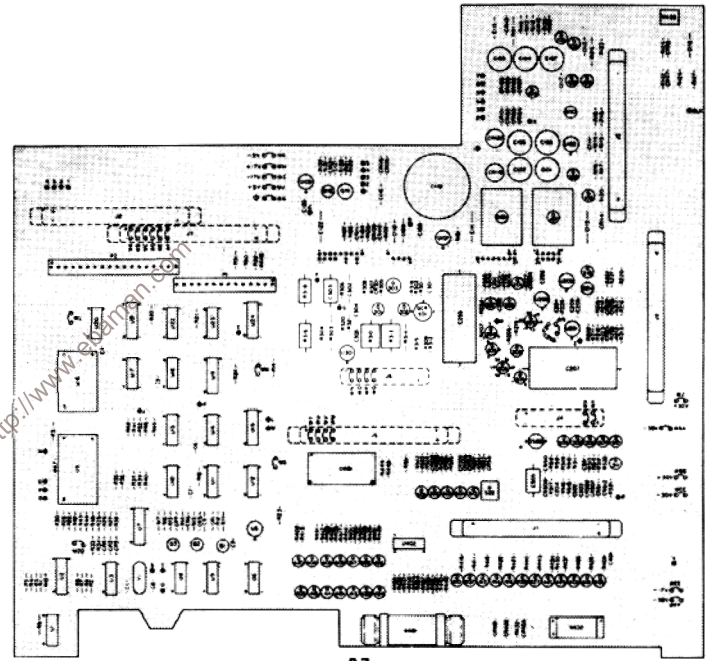

A1

-hp- Part No. 03490-66551

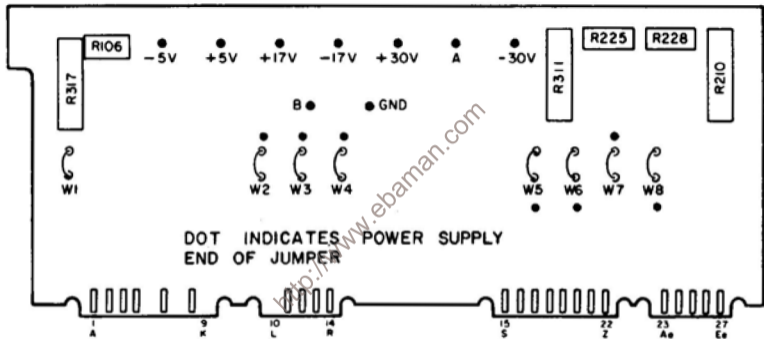

AIAI

3490A-B-2985

hp Part No. 03490-66521

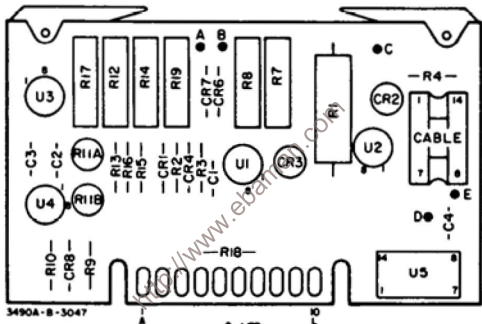

hp Part No. 03490-66513

A13 RATIO REFERENCE ASSEMBLY OPTION 080 (03490-66513)

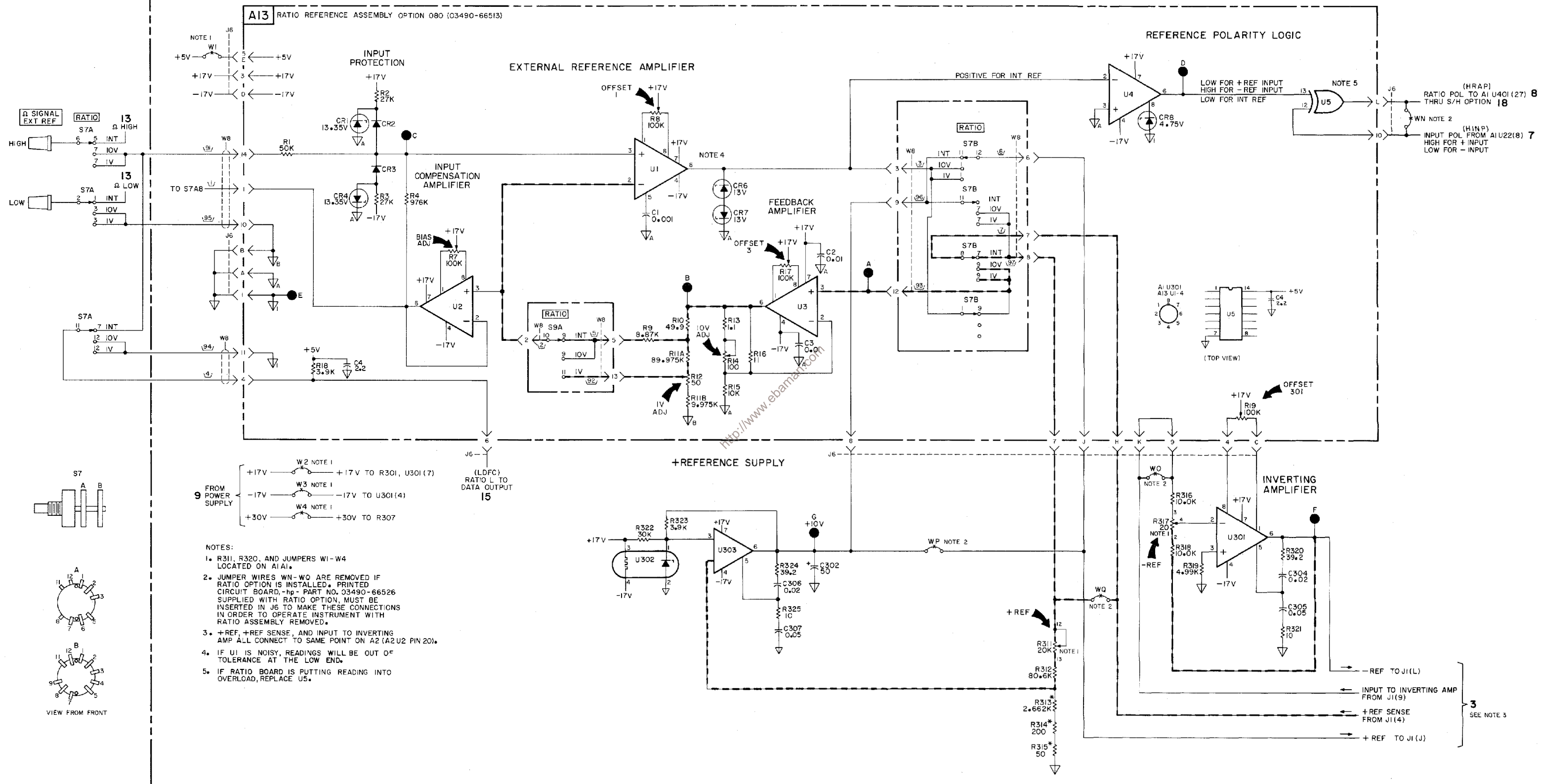

- NOTES:
1. R311, R320, AND JUMPERS W1-W4 LOCATED ON A1A1.
 2. JUMPER WIRES WN-W0 ARE REMOVED IF RATIO OPTION IS INSTALLED. PRINTED CIRCUIT BOARD, hp PART NO. 03490-66526 SUPPLIED WITH RATIO OPTION, MUST BE INSERTED IN J6 TO MAKE THESE CONNECTIONS IN ORDER TO OPERATE INSTRUMENT WITH RATIO ASSEMBLY REMOVED.
 3. +REF, +REF SENSE, AND INPUT TO INVERTING AMP ALL CONNECT TO SAME POINT ON A2 (A2U2 PIN 20).
 4. IF U1 IS NOISY, READINGS WILL BE OUT OF TOLERANCE AT THE LOW END.
 5. IF RATIO BOARD IS PUTTING READING INTO OVERLOAD, REPLACE U5.

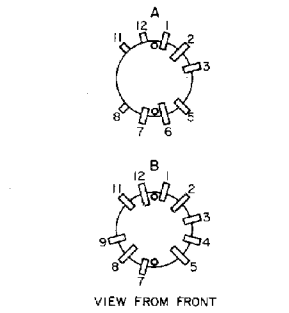
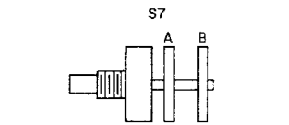
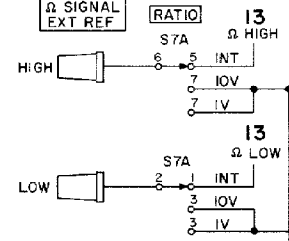
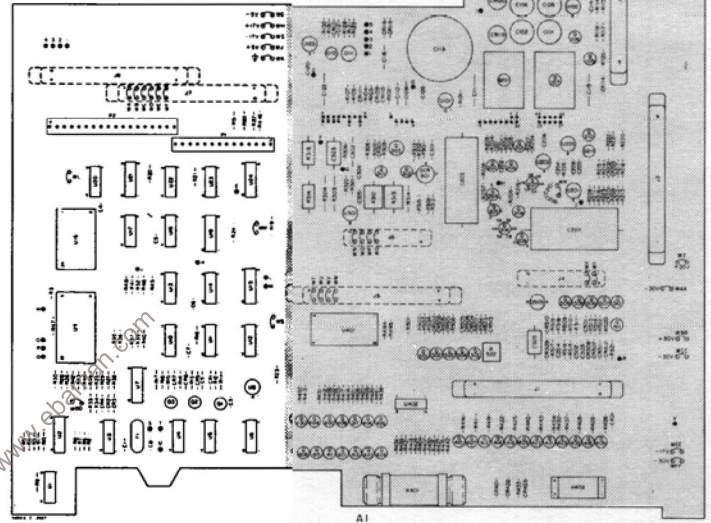
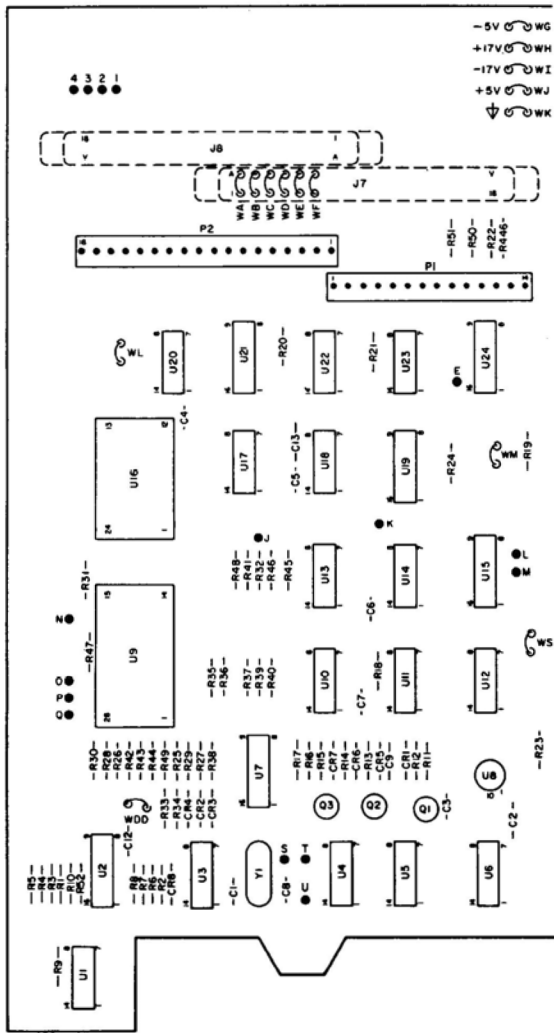
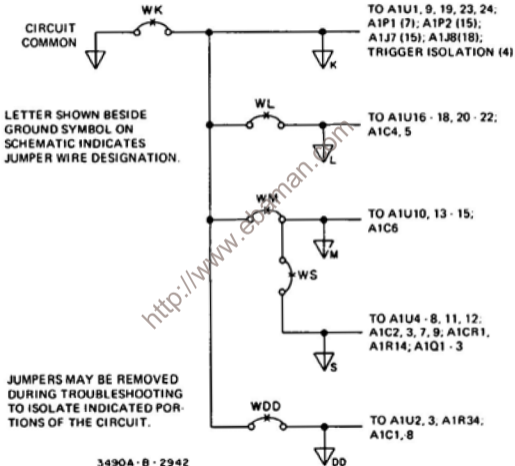

Figure 7-22. Schematic Diagram, Reference and Ratio Circuits, A1, A13.



-hp Part No. 03490-66551

GROUND CIRCUIT JUMPER WIRES ON MAIN CIRCUIT ASSEMBLY A1



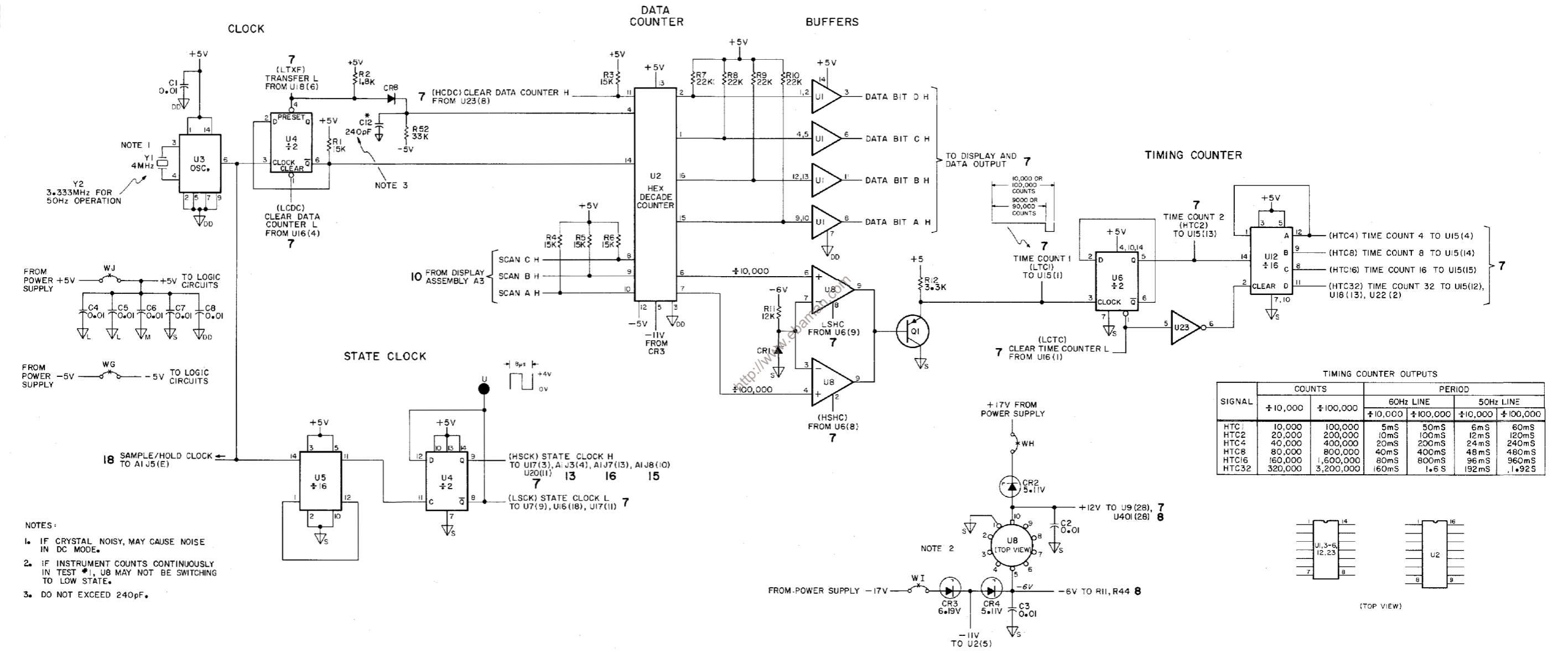
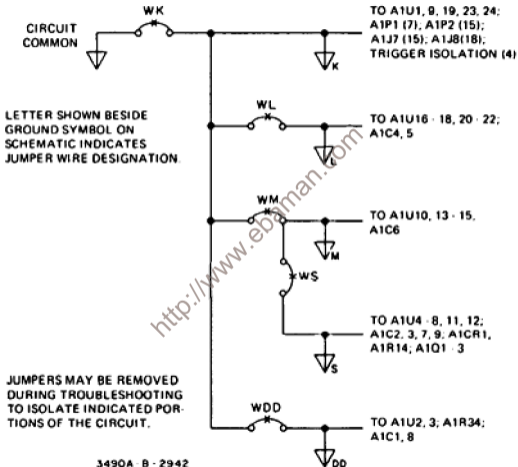
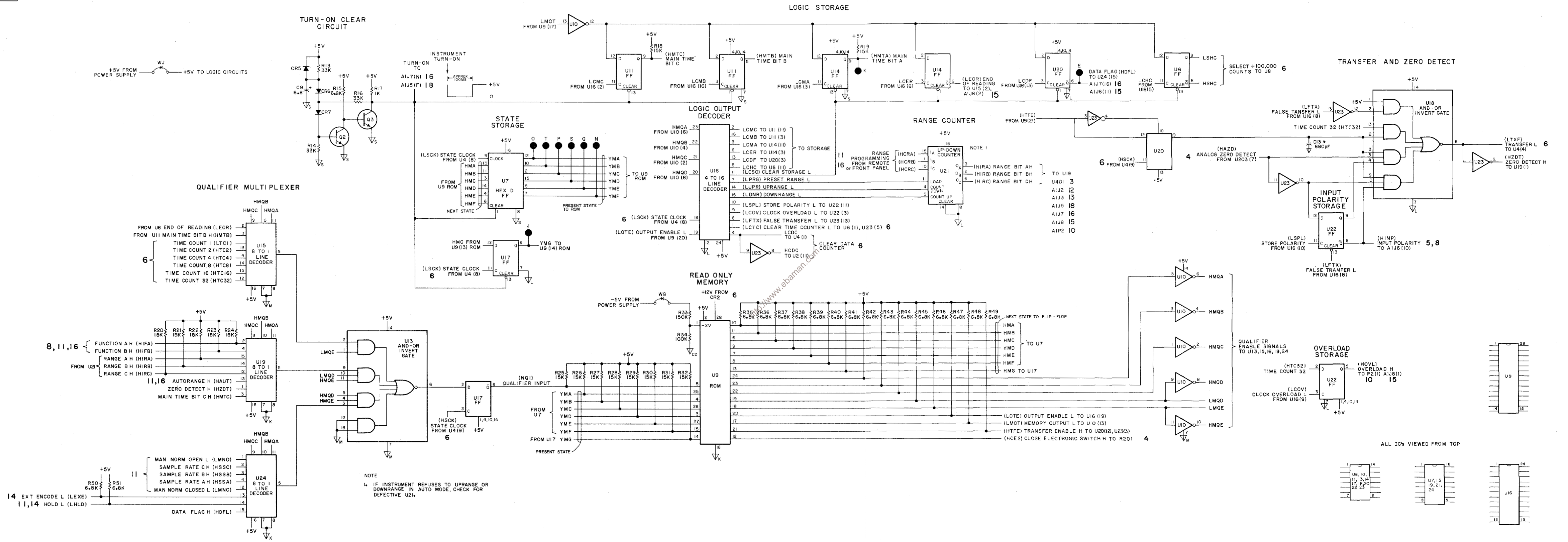

Figure 7-23. Schematic Diagram, Clock and Counters, AI.

GROUND CIRCUIT JUMPER WIRES ON MAIN CIRCUIT ASSEMBLY A1





R429

-R124 -
-CR118 -
-C118 -
-R122 -
-CR117 -
-R126 -
-R127 -

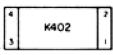
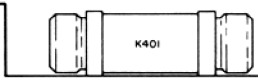
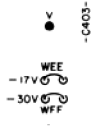
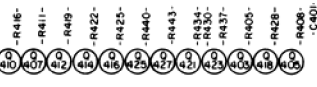
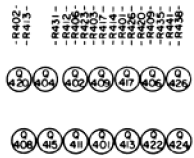
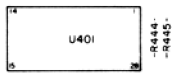
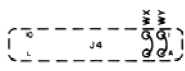
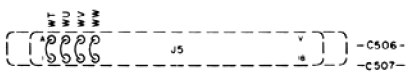
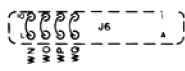

AI

-hp- Part No. 03490-66551

<http://www.esman.com>

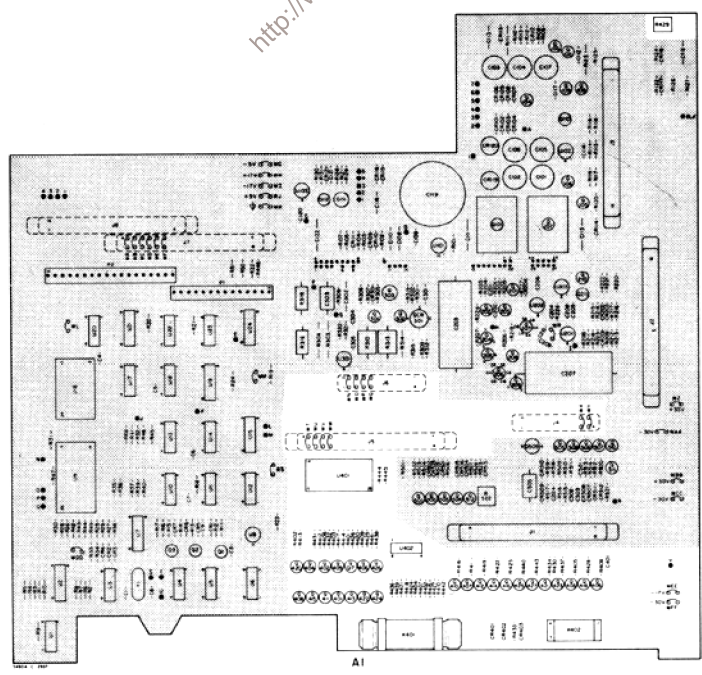

AI

-hp- Part No. 03490-66551

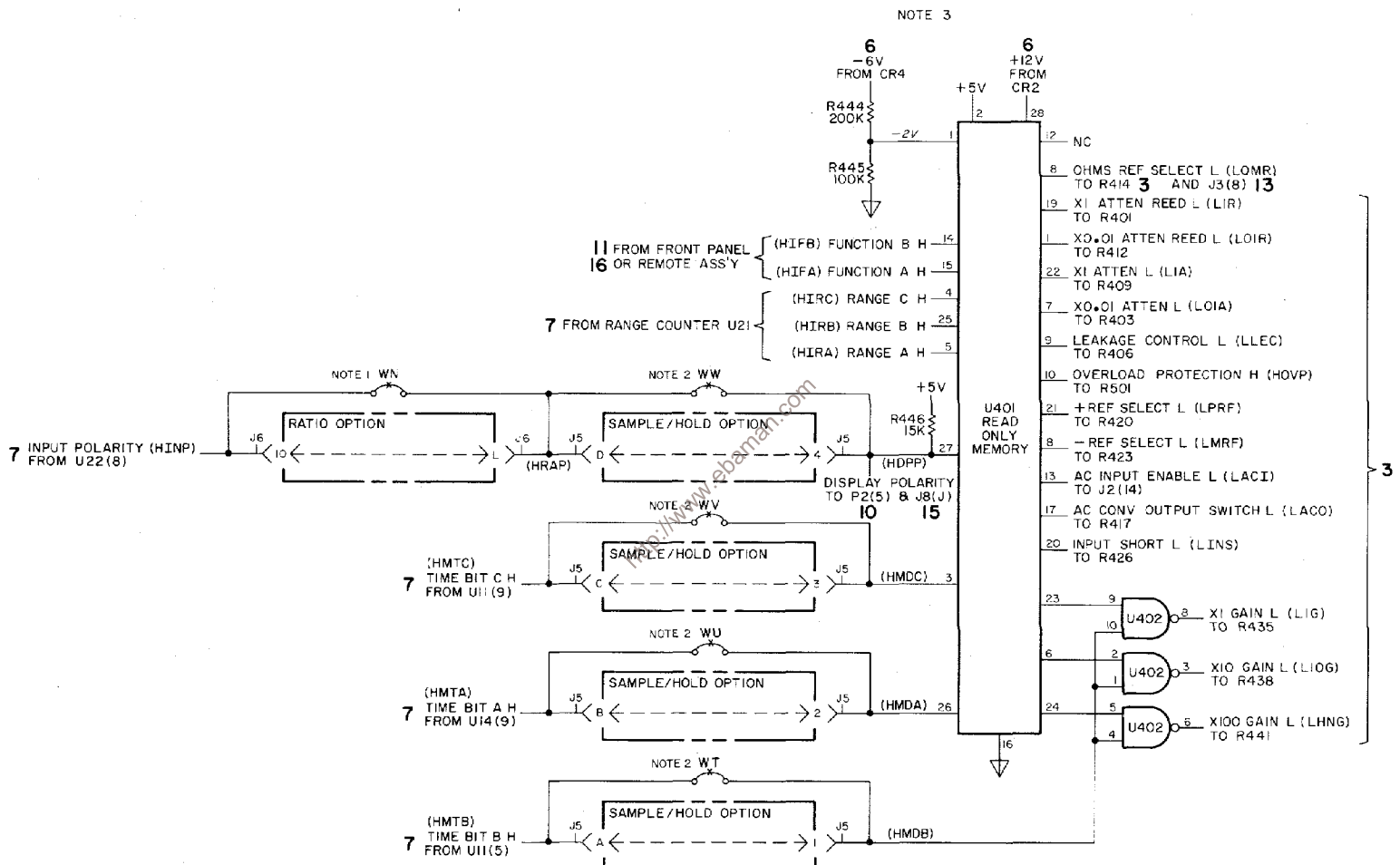

- NOTES:
1. IF RATIO OPTION IS INSTALLED, JUMPER WIRE WN IS REMOVED.
 2. IF SAMPLE/HOLD OPTION IS INSTALLED, JUMPER WIRES WT THRU WW ARE REMOVED.
 3. IF INSTRUMENT WORKS IN TEST #1 BUT NOT OTHERS, RESET U401.

Figure 7-25. Schematic Diagram, DC Switching Logic, AI. 7-49/7-50

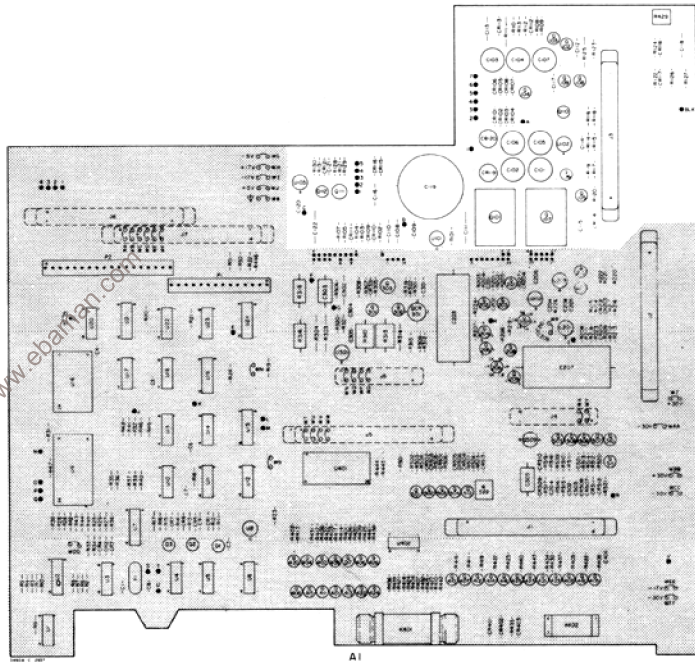
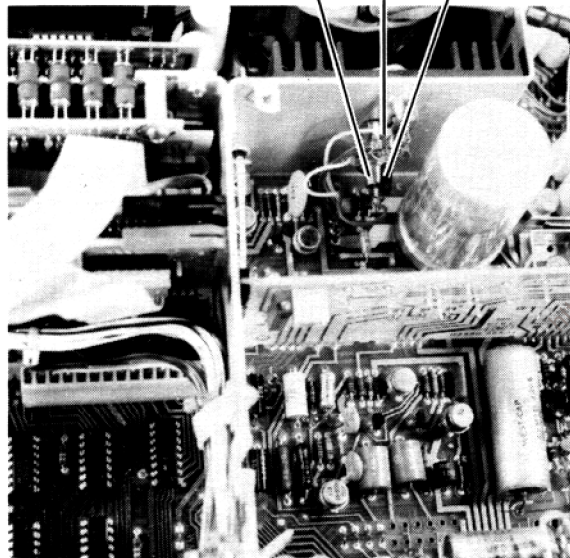

-hp- Part No. 03490-66551

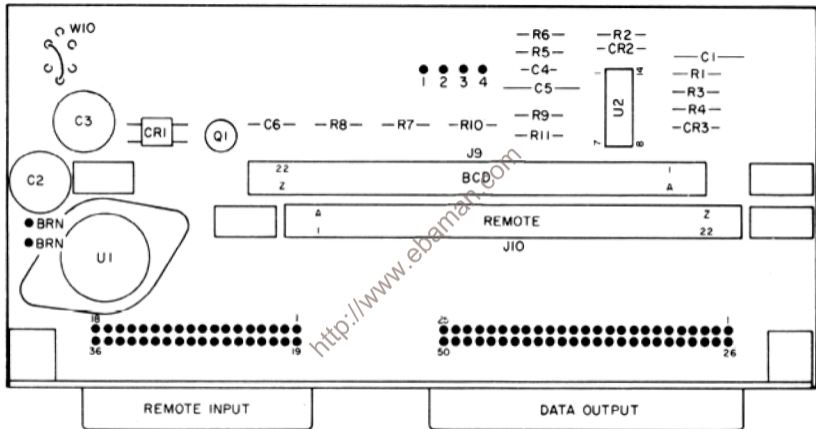

3490A - B - 2984

A8

hp Part No. 03490-66508

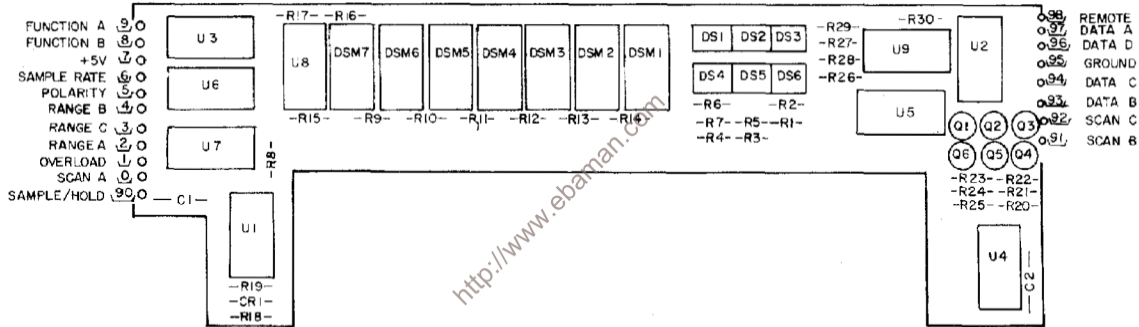

A3

hp Part No. 03490-66543

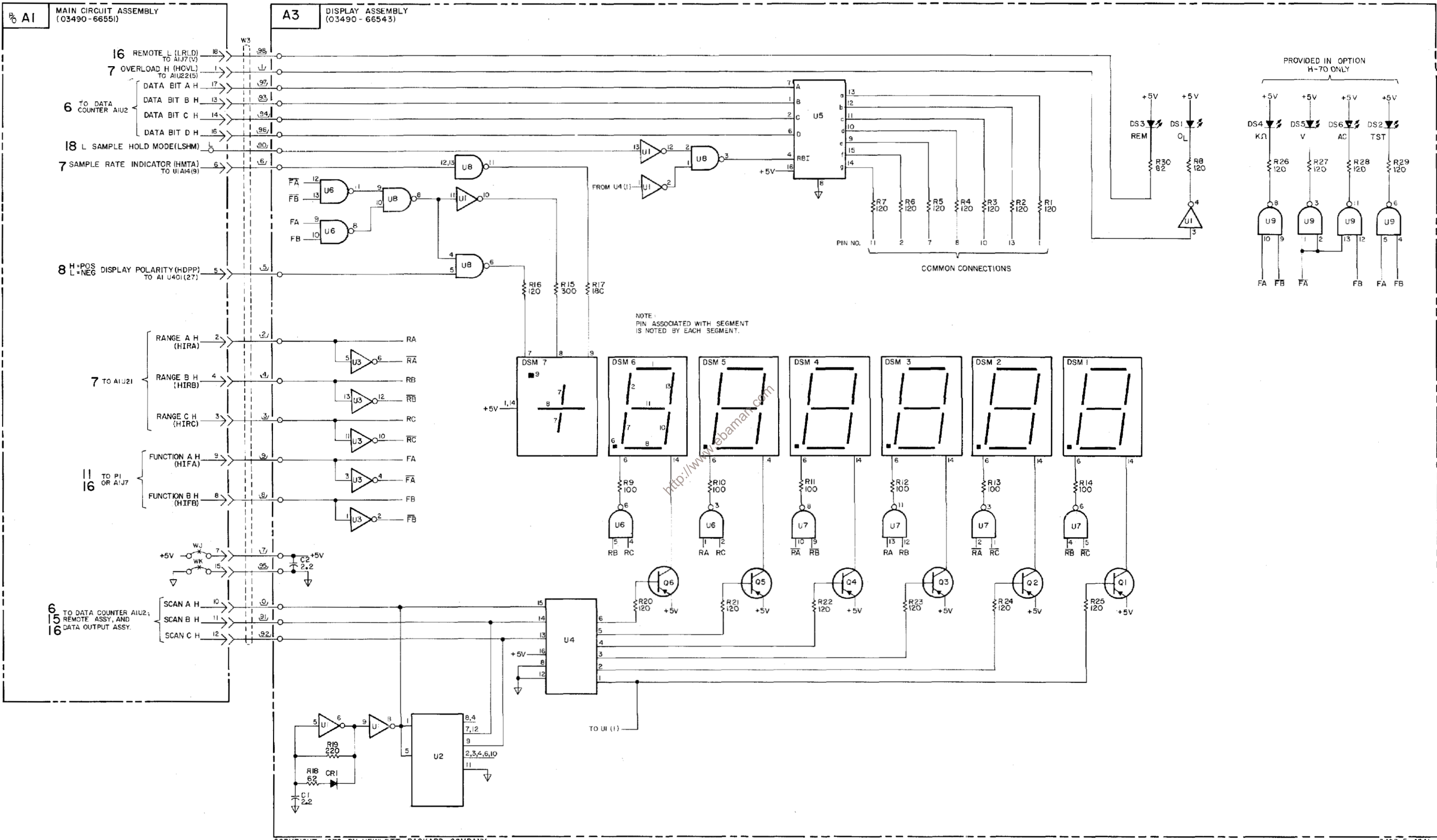
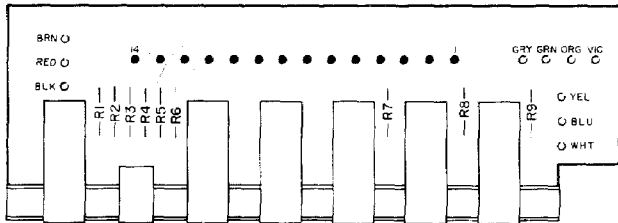

Figure 7-27. Schematic Diagram, Display, A3.



3490A-B-2983

A5

hp Part No. 03490-66505

COMPONENT SIDE

Rev. E

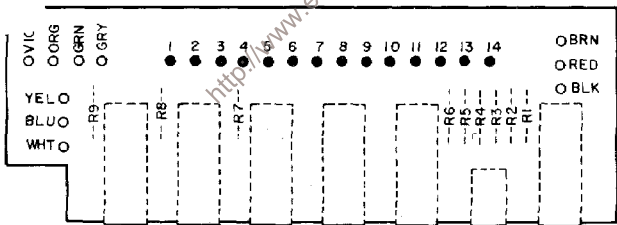

3490-B-3599

A5

hp Part No. 03490-66505

CIRCUIT SIDE

Rev. E

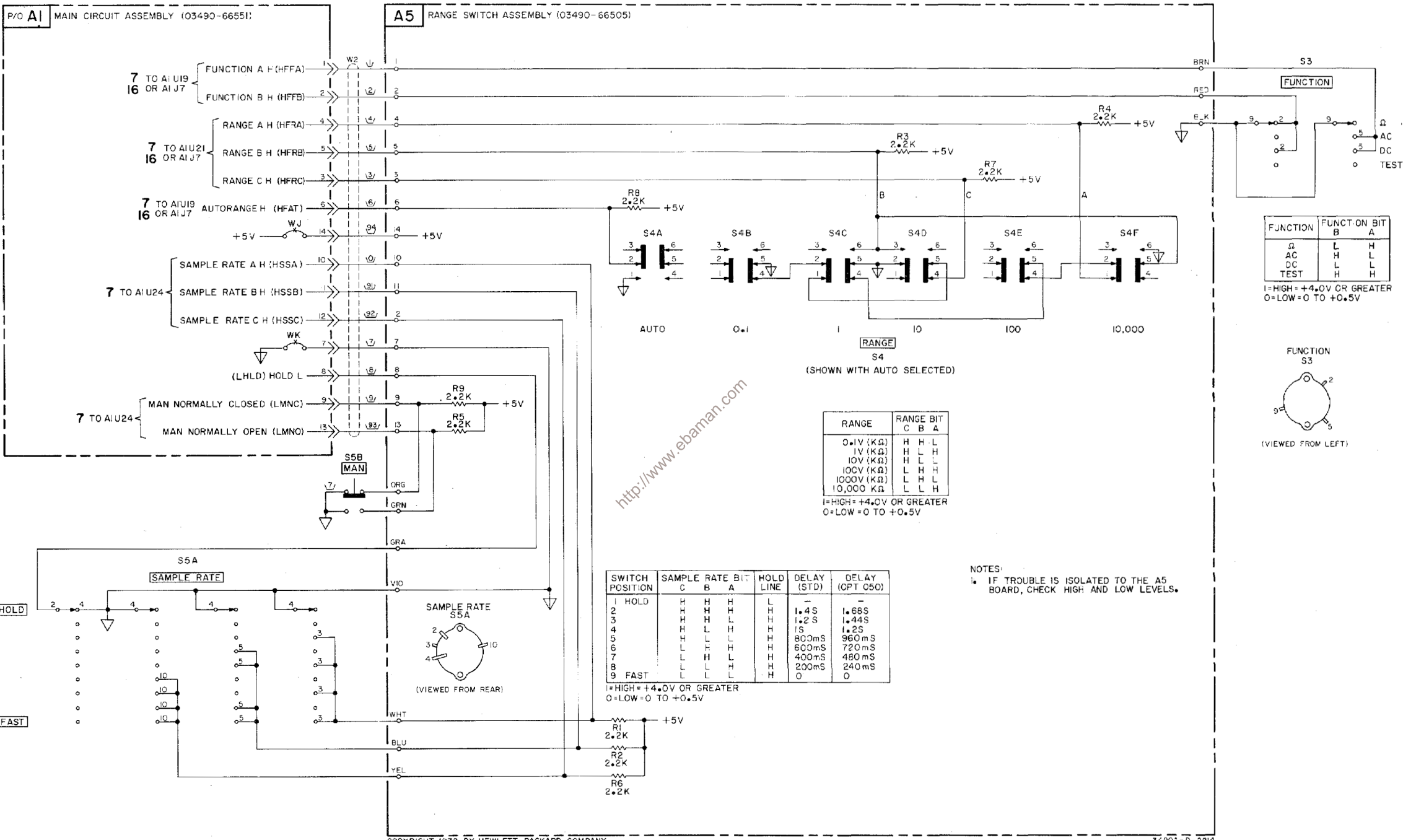

COPYRIGHT 1972 BY HEWLETT-PACKARD COMPANY

Figure 7-28. Schematic Diagram, Function, Range, and Sample Rate Switches, A5.

7-55/7-56

34902-0-2814

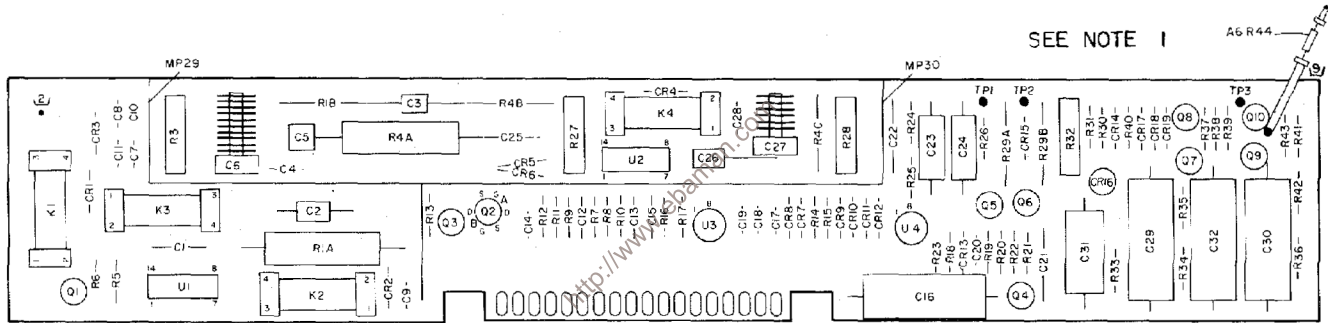

SEE NOTE 1

A6R44

3490A-B-2978

A6

hp Part No. 03490-66506
Rev B

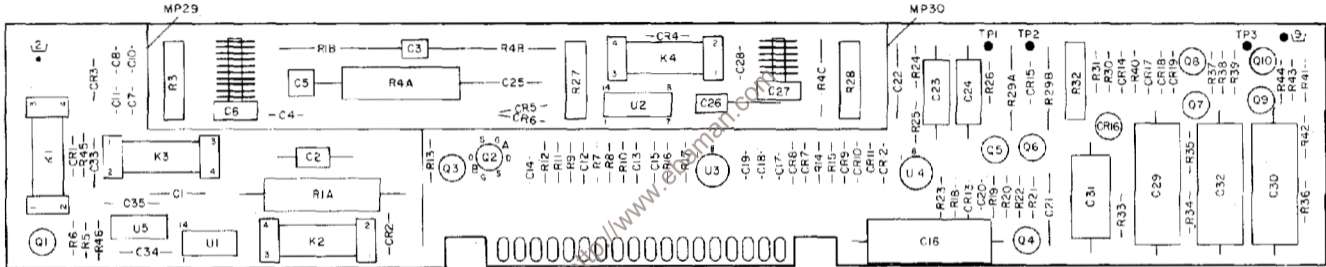

3490A-B-4223

A6
 hp Part No. 03490-66506
 Rev D

CONVERTER AMPLIFIER

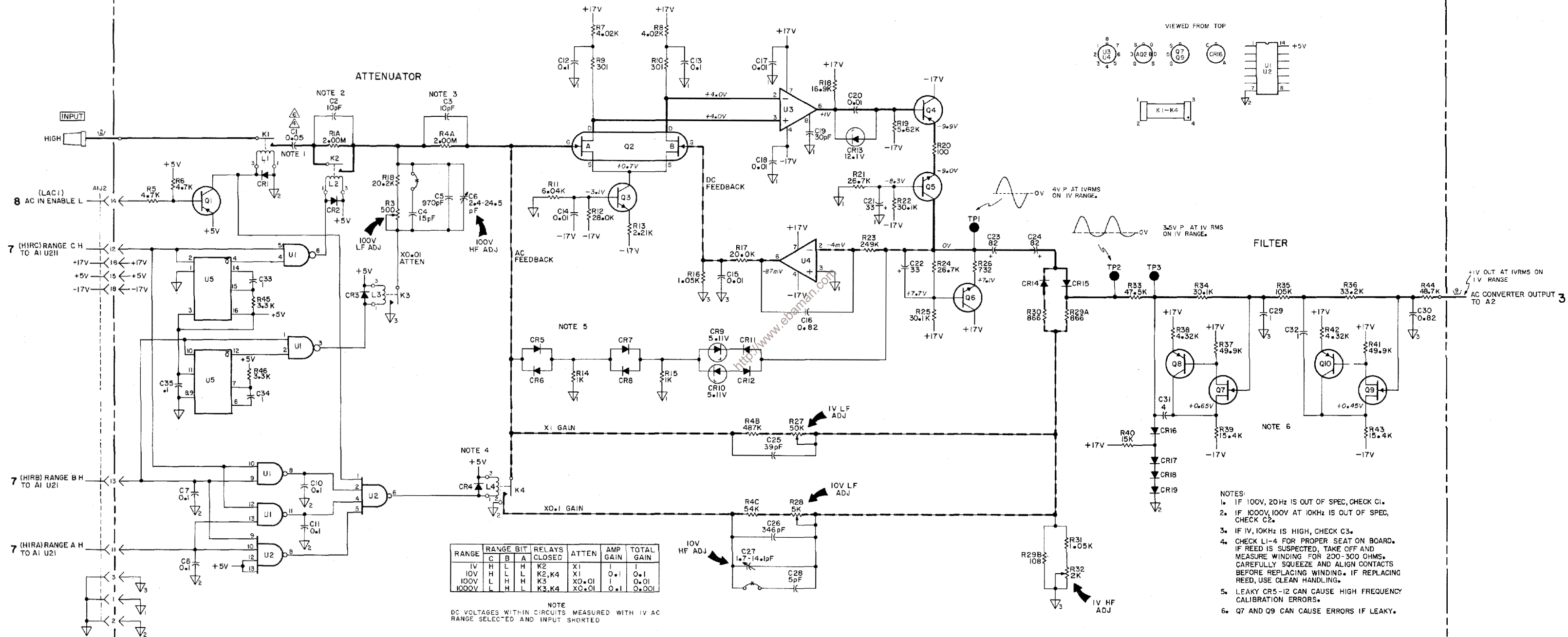

RANGE	C	B	A	RELAYS CLOSED	ATTEN	AMP GAIN	TOTAL GAIN
1V	H	L	H	K2	X1	1	1
10V	H	L	L	K2, K4	X1	0.1	0.1
100V	L	H	H	K3	X0.01	1	0.01
1000V	L	H	L	K3, K4	X0.01	0.1	0.001

NOTE
DC VOLTAGES WITHIN CIRCUITS MEASURED WITH 1V AC RANGE SELECTED AND INPUT SHORTED.

- NOTES:
1. IF 100V, 20Hz IS OUT OF SPEC, CHECK C1.
 2. IF 1000V, 100V AT 10KHz IS OUT OF SPEC, CHECK C2.
 3. IF 1V, 10KHz IS HIGH, CHECK C3.
 4. CHECK LI-4 FOR PROPER SEAT ON BOARD. IF REED IS SUSPECTED, TAKE OFF AND MEASURE WINDING FOR 200-300 OHMS. CAREFULLY SQUEEZE AND ALIGN CONTACTS BEFORE REPLACING WINDING. IF REPLACING REED, USE CLEAN HANDLING.
 5. LEAKY CR5-12 CAN CAUSE HIGH FREQUENCY CALIBRATION ERRORS.
 6. Q7 AND Q9 CAN CAUSE ERRORS IF LEAKY.

Figure 7-29. Schematic Diagram, AC Converter, A6. 7-57/7-58

Components this side of board can be replaced.

Clean Handled Section

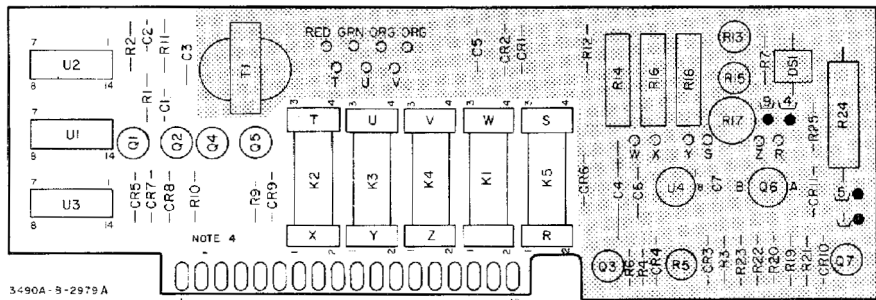

A7

hp Part No. 03490-66507

Rev. B

Components this side of board can be replaced.

Clean Handled Section

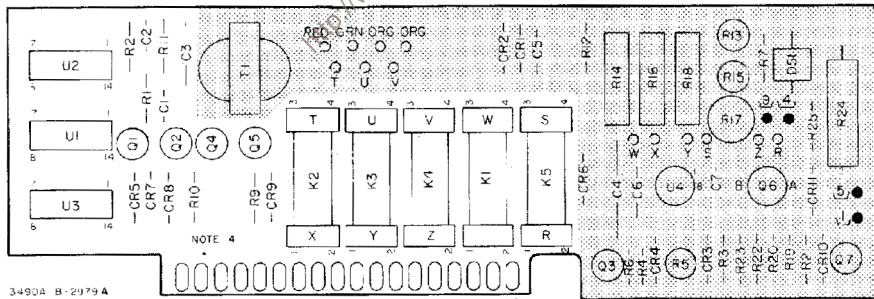

A7

hp Part No. 03490-66507

Rev. C

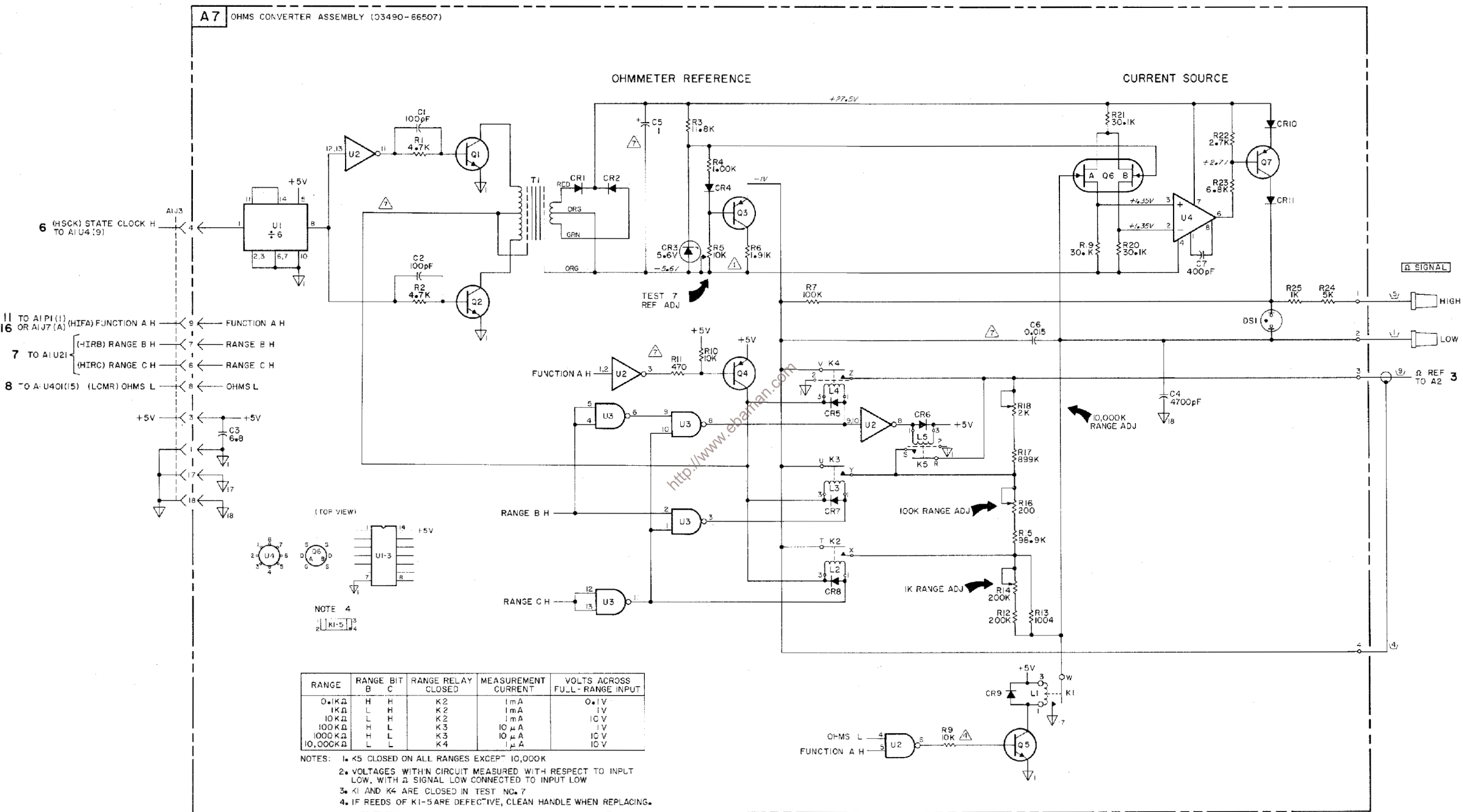

RANGE	RANGE BIT B	RANGE BIT C	RANGE RELAY CLOSED	MEASUREMENT CURRENT	VOLTS ACROSS FULL-RANGE INPUT
0.1KΩ	H	H	K2	1mA	0.1V
1KΩ	L	H	K2	1mA	1V
10KΩ	H	L	K3	10μA	10V
100KΩ	H	L	K3	10μA	1V
1,000KΩ	H	L	K3	10μA	10V
10,000KΩ	L	L	K4	1μA	10V

- NOTES:
1. K5 CLOSED ON ALL RANGES EXCEPT 10,000K
 2. VOLTAGES WITHIN CIRCUIT MEASURED WITH RESPECT TO INPLT LOW, WITH Ω SIGNAL LOW CONNECTED TO INPUT LOW
 3. K1 AND K4 ARE CLOSED IN TEST NO. 7
 4. IF REEDS OF K1-5 ARE DEFECTIVE, CLEAN HANDLE WHEN REPLACING.

Figure 7-30. Schematic Diagram, Ohms Converter, A7. 7-59/7-60

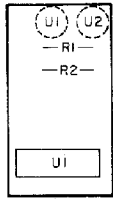

A22A1

hp Part No. 03490-66522
3490A-B-3002

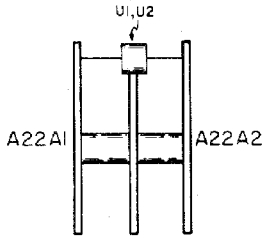

A22

hp Part No. 03490-60302

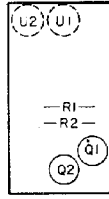

A22A2

hp Part No. 03490-66523

U1, U2
OPTICAL ISOLATORS

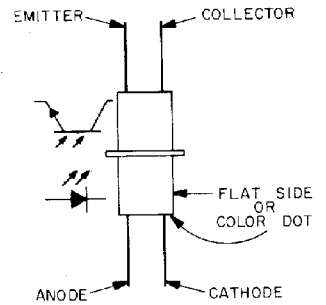

-hp- PART NO. 5080-9052
and
-hp- PART NO. 1990-0402

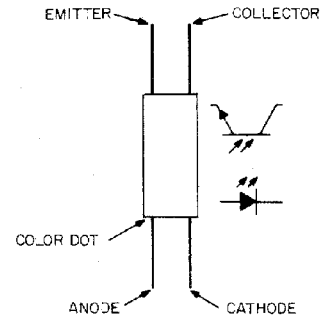

-hp- PART NO. 1990-0514

If an optical isolator is to be replaced, see Section VIII, Backdating, Change No. 9 table to determine correct part number.

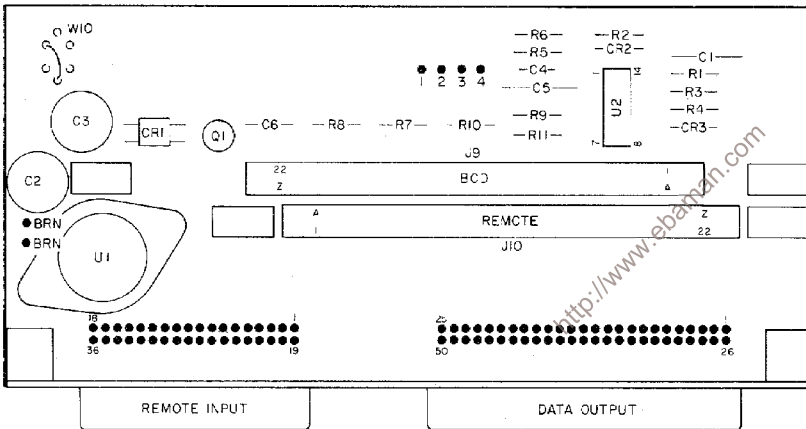

A8

hp Part No. 03490-66508

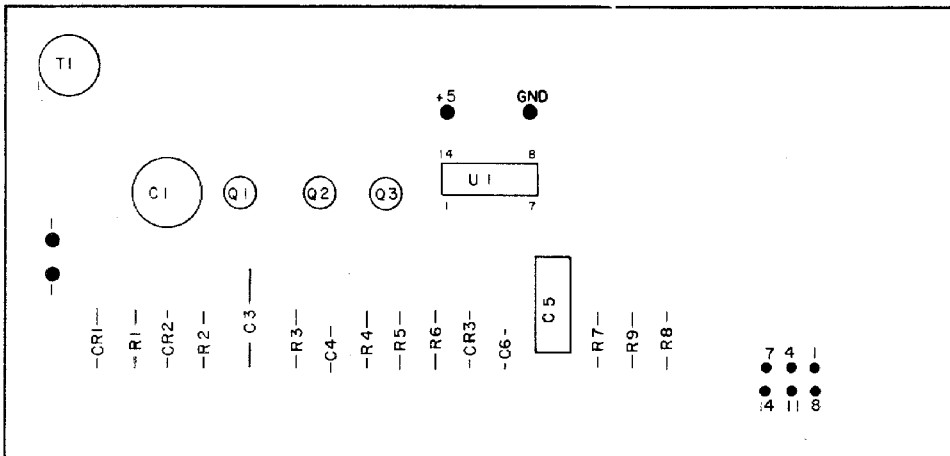

A 29

hp Part No. 11118-26501

Rev. A

A37
SAMPLE/HOLD TRIGGER GATE ASSEMBLY
 OPTION 045 (11118-66502)

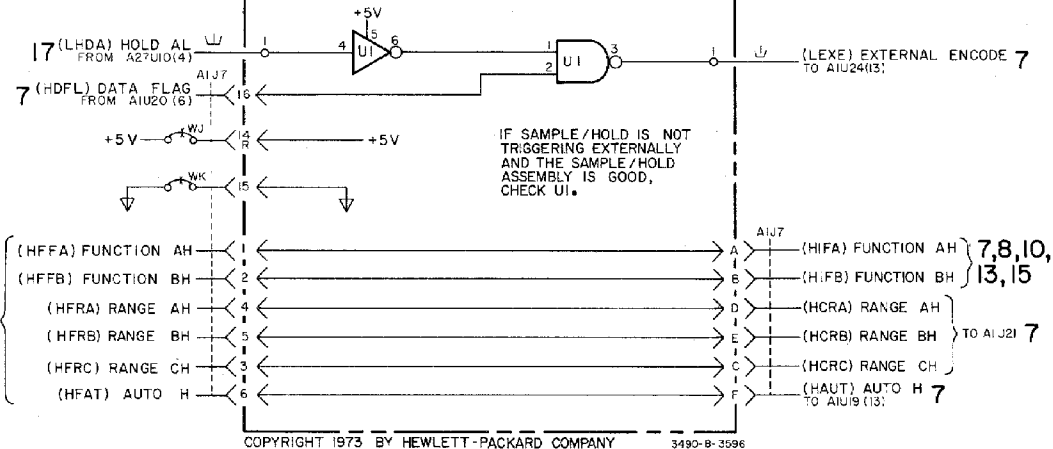
 11 FROM
 FRONT
 PANEL
 SWITCHES
**A29**
OUTGUARD SAMPLE/HOLD TRIGGER ASSY.
 (11118-66501)

SAMPLE/HOLD TRIGGER CIRCUIT

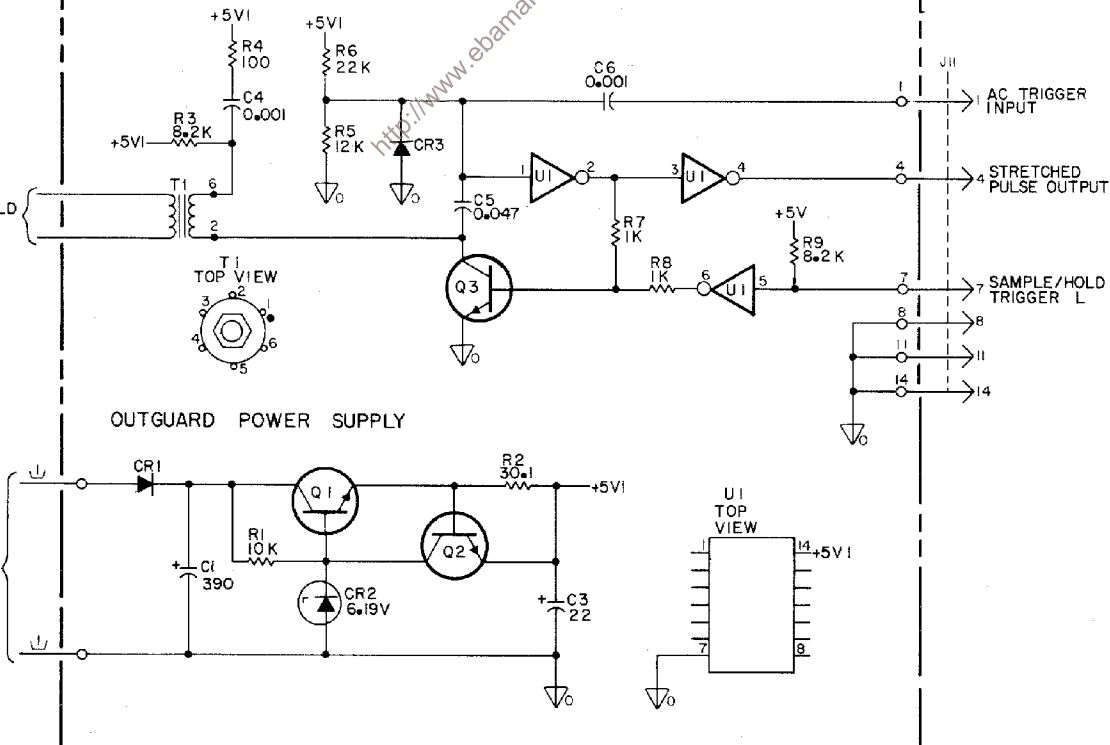
 18 SAMPLE/HOLD
 TRIGGER L
 TO A28

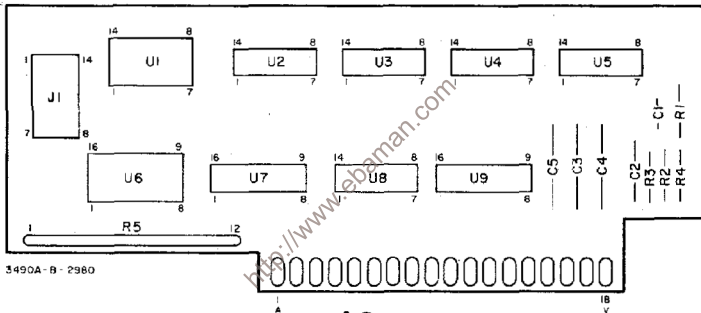

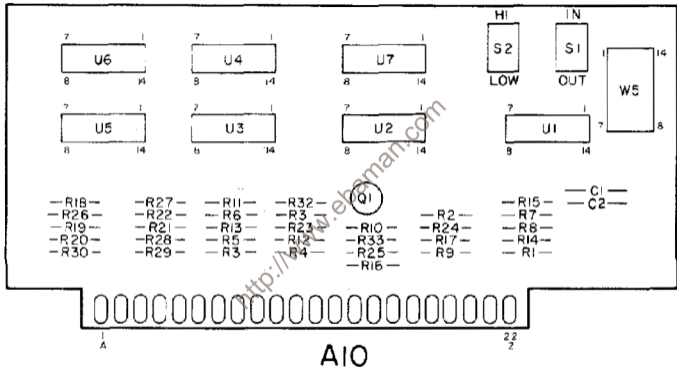

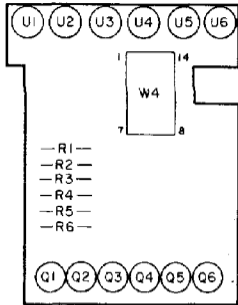

A15A1

hp Part No. 03490-66515

3490A - B - 3000

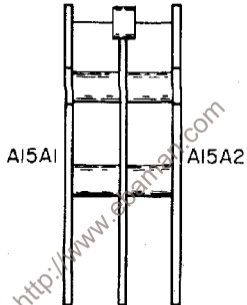

A15

hp Part No. 03490-60306

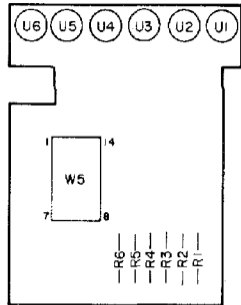

A15A2

hp Part No. 03490-66516

U1-U6

OPTICAL ISOLATORS

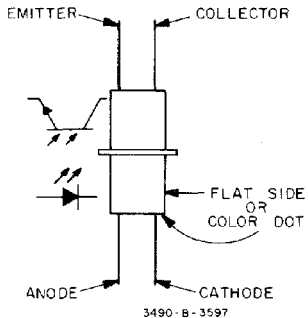

-hp- PART NO. 5080-9052
and
-hp- PART NO. 1990-0402

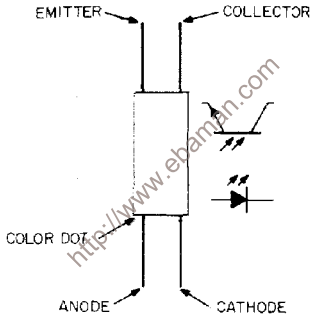

-hp- PART NO. 1990-0514

If an optical isolator is to be replaced, see Section VIII, Backdating, CHANGE NO. 9, Table 8-2 to determine correct Part No.

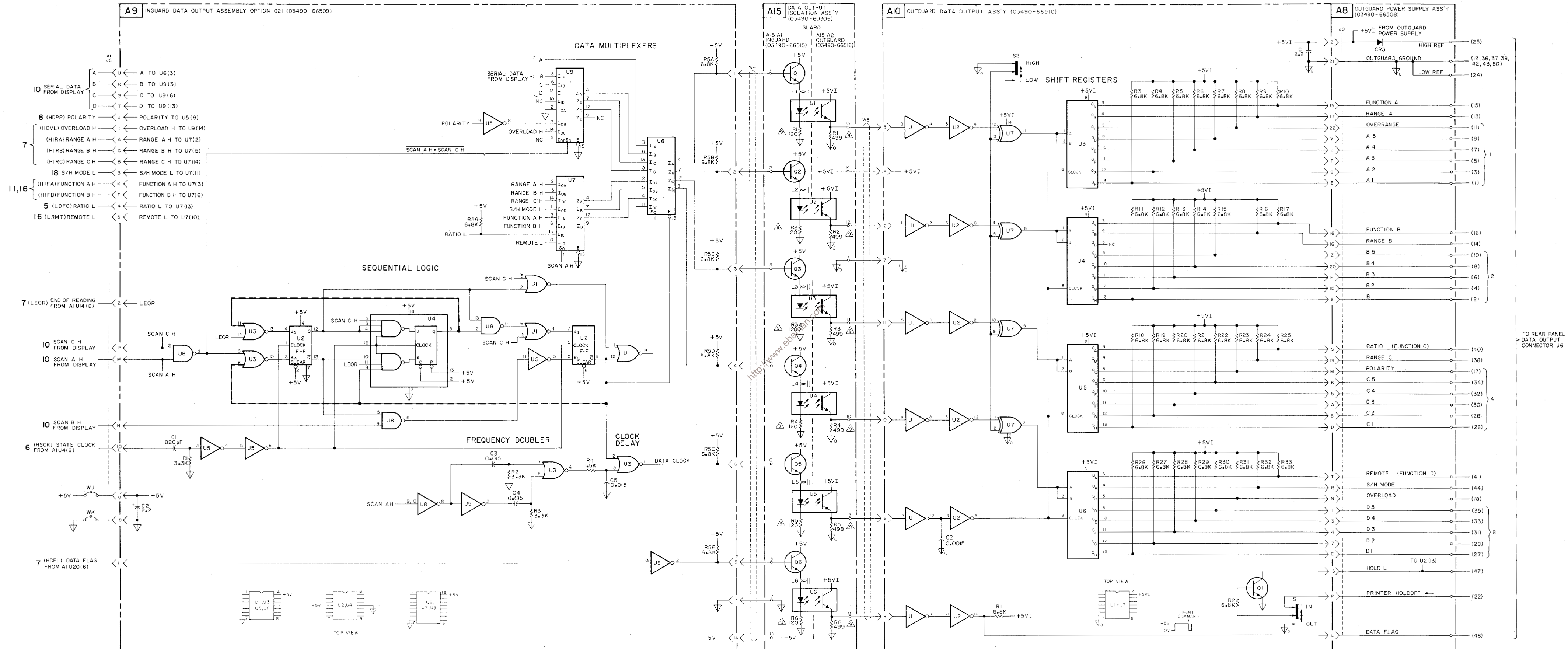
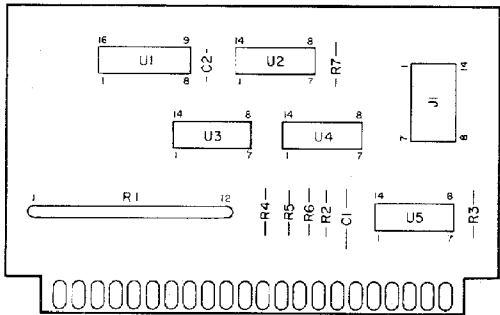
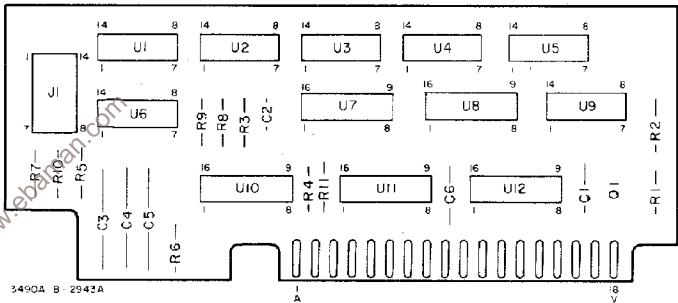

Figure 7-32. Schematic Diagram, Data Output Option 021, 7-63/7-64



3490A-B-2986

AI2
hp Part No. 03490-66512



3490A-B-2943A

A11
hp Part No. 03490-66511
 Rev. C



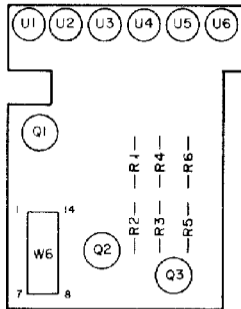

A17A1

hp Part No. 03490-66517

3490A-B-3001

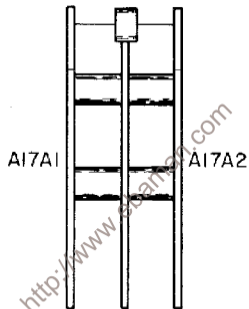

A17

hp Part No. 03490-60308

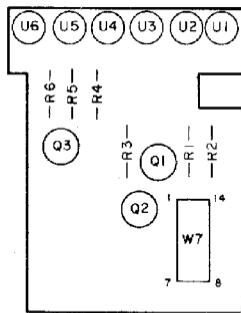

A17A2

hp Part No. 03490-66518

U1-U6

OPTICAL ISOLATORS

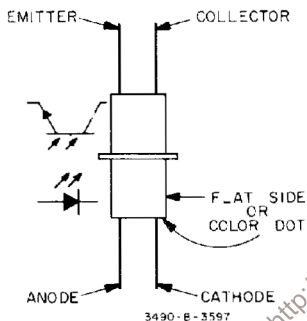

-hp- PART NO. 5080-9052
and
-hp- PART NO. 1990-0402

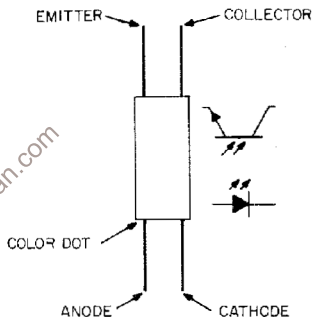

-hp- PART NO. 1990-0514

If an optical isolator is to be replaced, see Section VIII, Backdating, CHANGE NO. 9, Table 8-2 to determine correct Part No.

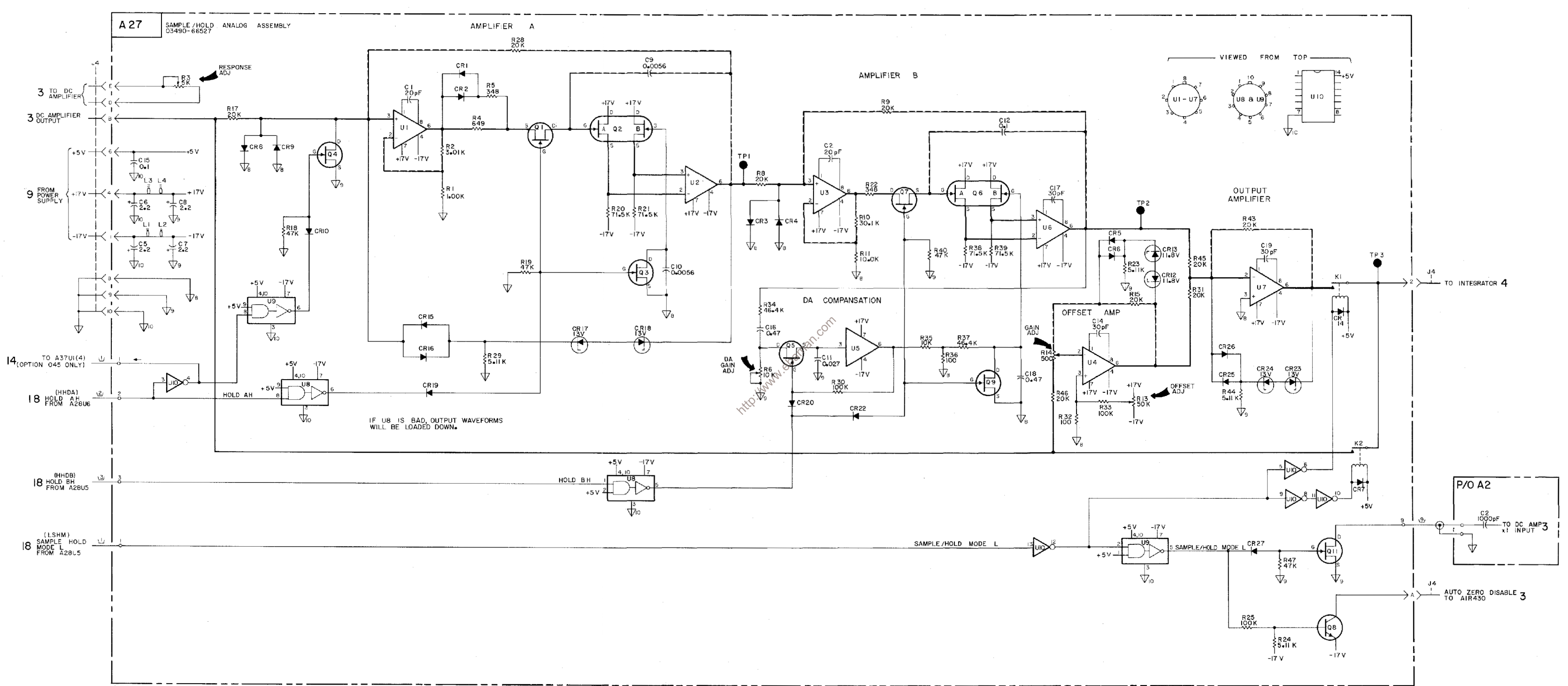
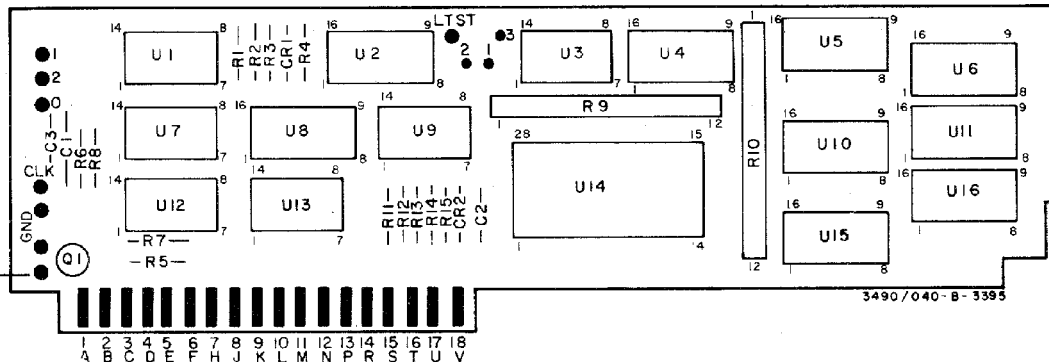

Figure 7-34. Schematic Diagram, Sample/Hold Analog Circuits, A27.

7-67/7-68

3490/040-E 3392



3490/040-B-3395

A28

hp Part No. 03490-66528

Rev. C

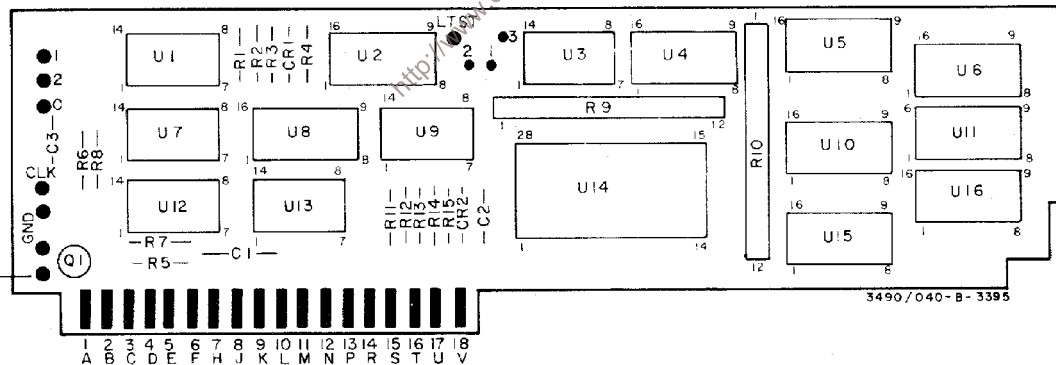

3490/040-B-3395

A28

hp Part No. 03490-66528

Rev. D

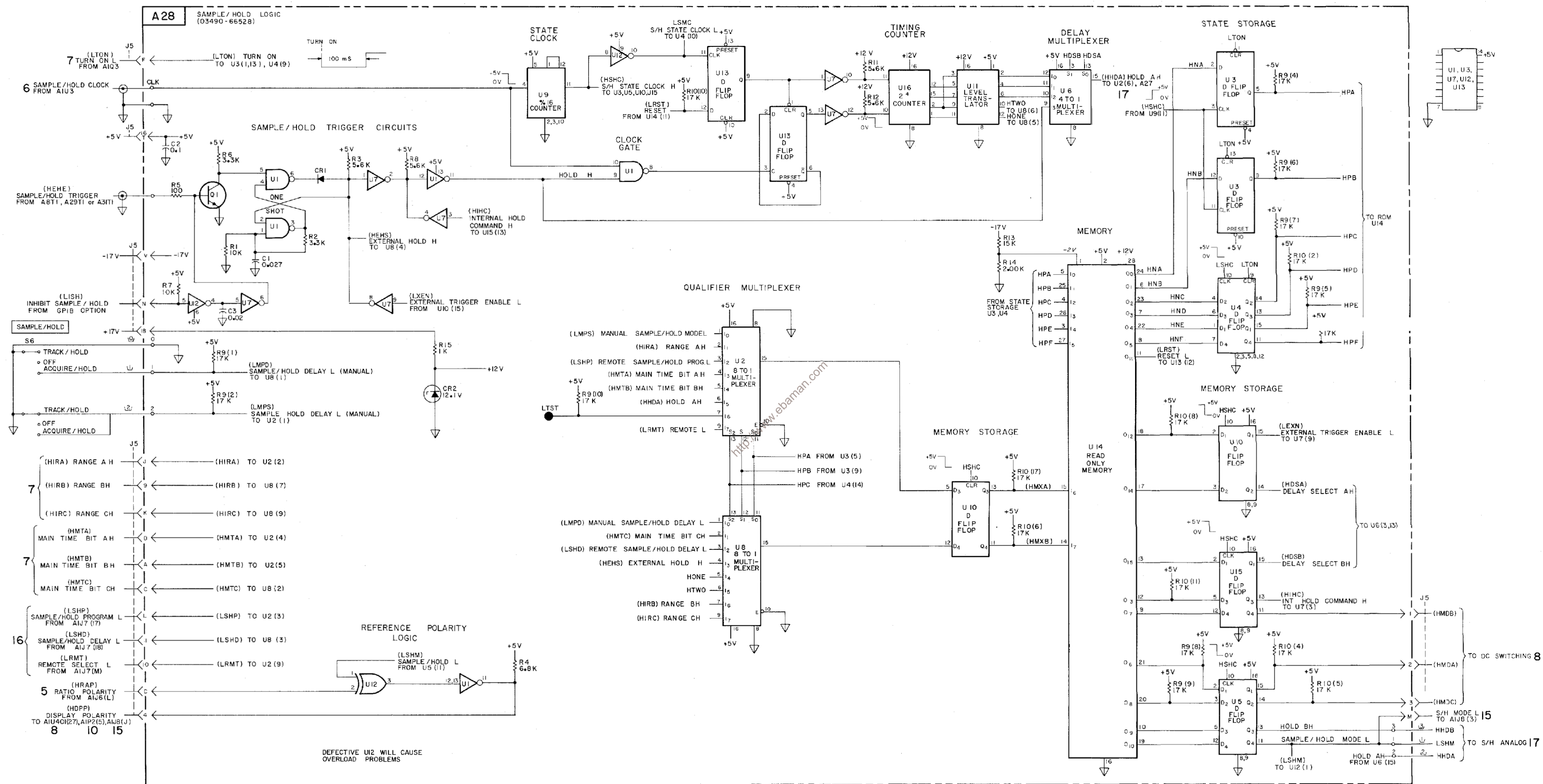

Figure 7-35. Schematic Diagram, Sample/Hold Logic Circuits, A28.

7-69/7-70

3490/040-E-5393

Table 7-7. Alphabetical Listing of 3490A HP-IB I/O Mnemonics.

AAA	Assigned Address Bit A	IFB	Internal Function Bit B
AAB	Assigned Address Bit B	IOA	Inguard to Outguard Data Bit A
AAC	Assigned Address Bit C	IOB	Inguard to Outguard Data Bit B
AAD	Assigned Address Bit D	IOC	Inguard to Outguard Data Bit C
AAE	Assigned Address Bit E	IOD	Inguard to Outguard Data Bit D
ADT	Addressed to Talk	IRA	Internal Range Bit A
AOH	ASCII Output Bit H	IRB	Internal Range Bit B
ATR	Autorange Programmed	IRC	Internal Range Bit C
AUT	Internal Autorange	ISH	Inhibit Sample/Hold
CDS	Clear Designator Counter	ITK	Inhibit Talk Only
CLK	System Clock	MRE	Multiple Response Enable
CRA	Combined Range Bit A	MRO	Multiple Response Override
CRB	Combined Range Bit B	MXA	Multiplexer Select Bit A
CRC	Combined Range Bit C	MXB	Multiplexer Select Bit B
CRS	Clear Remote Storage	MXC	Multiplexer Select Bit C
DAC	Data Accepted	MXD	Multiplexer Select Bit D
DAV	Data Valid	MXE	Multiplexer Select Bit E
DCA	Data Counter Bit A	NPD	New Programming Data
DCB	Data Counter Bit B	ODE	Output Data Enable
DCC	Data Counter Bit C	ODS	Output Data Select
DCD	Data Counter Bit D	OEN	Output Enable
DFC	Data Function C (Ratio)	OEO	Output Enable Override
DFL	Data Flag	OIA	Outguard to Inguard Data Bit A
DIO1	Data Input/Output Bit 1	OIB	Outguard to Inguard Data Bit B
DIO2	Data Input/Output Bit 2	OIC	Outguard to Inguard Data Bit C
DIO3	Data Input/Output Bit 3	OID	Outguard to Inguard Data Bit D
DIO4	Data Input/Output Bit 4	OIM	Outguard to Inguard Multiplexer Select Bit
DIO5	Data Input/Output Bit 5	OVL	Overload
DIO6	Data Input/Output Bit 6	PSA	Present State Bit A
DIO7	Data Input/Output Bit 7	PSB	Present State Bit B
DIO8	Data Input/Output Bit 8	PSC	Present State Bit C
DMA	Decoder Bit A	PSD	Present State Bit D
DMB	Decoder Bit B	PSE	Present State Bit E
DMC	Decoder Bit C	PSF	Present State Bit F
DMD	Decoder Bit D	PSG	Present State Bit G
DOA	Data Output Bit A	PSH	Present State Bit H
DOB	Data Output Bit B	QF1	Qualifier Bit 1
DOC	Data Output Bit C	QLF	Qualifier Bit
DOD	Data Output Bit D	REN	Remote Enable
DPP	Displayed Polarity	RFD	Ready For Data
EOP	End Output	RLD	Remote LED
ETF	External Trigger Flag	RMT	Remote Operation
ETR	External Trigger	RST	Reset
EXE	External Encode	SA	Scan A
FAT	Front Panel Autorange	SB	Scan B
FFA	Front Panel Function Bit A	SC	Scan C
FFB	Front Panel Function Bit B	SCK	State Clock
FRA	Front Panel Range Bit A	SDO	Store Data for Output
FRB	Front Panel Range Bit B	SHD	Sample/Hold Delay
FRC	Front Panel Range Bit C	SHM	Sample/Hold Mode
GTI	Guard Transfer Initiate	SHP	Sample/Hold Program
GTR	Guard Transfer Receive	SPD	Store Programming Data
HLD	Hold	SRQ	Service Request
IDS	Increment Designator Counter	SSD	Set Stored Data Flip-Flop
IFA	Internal Function Bit A	TKO	Talk Only

H preceding mnemonic means HIGH is true; L means LOW is true.

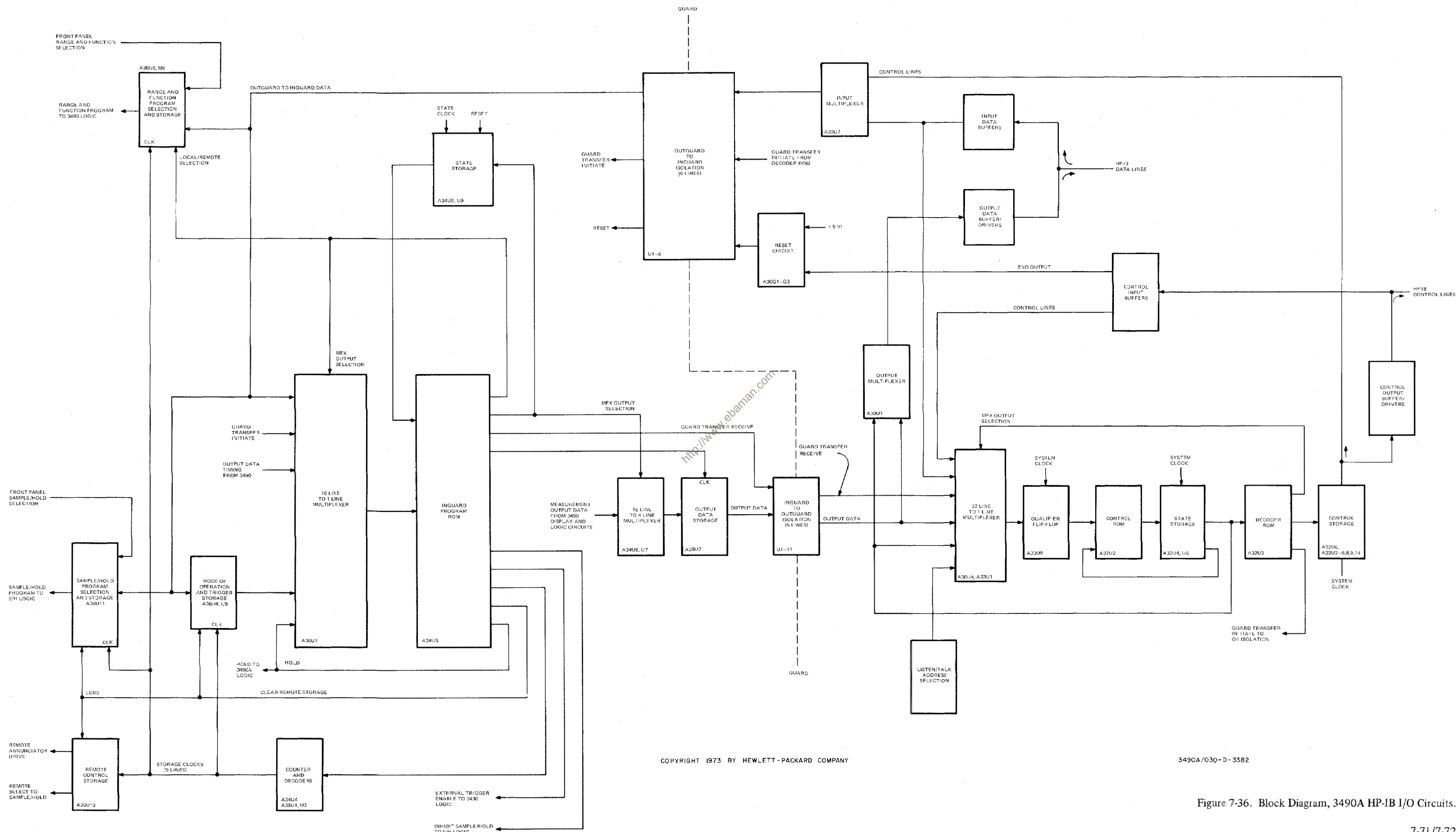

COPYRIGHT 1973 BY HEWLETT-PACKARD COMPANY

3490A/030-D-3382

Figure 7-36. Block Diagram, 3490A HP-IB I/O Circuits.

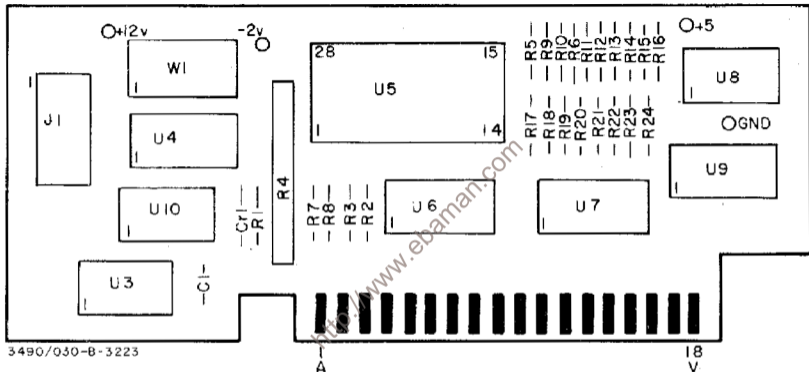

A34

hp Part No. 03490-66534
Rev. A

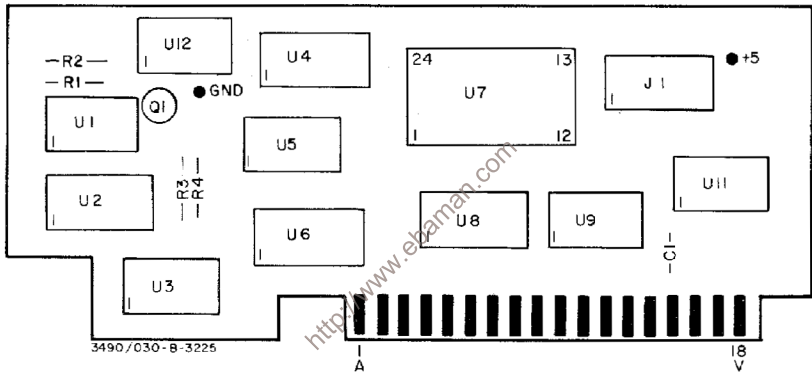

A36

hp Part No. 03490-66536
Rev A

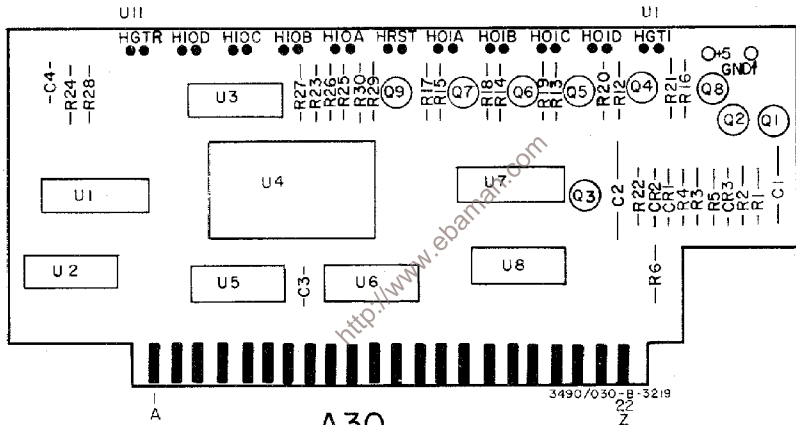

hp Part No. 03490-66530

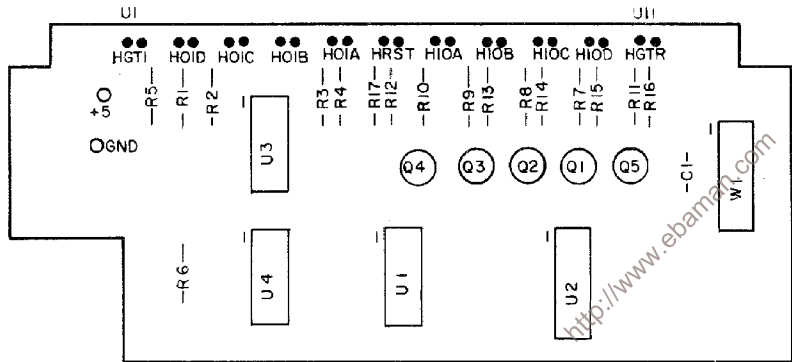

3490/030-B-3224

A 35

hp Part No. 03490-66535
Rev. A

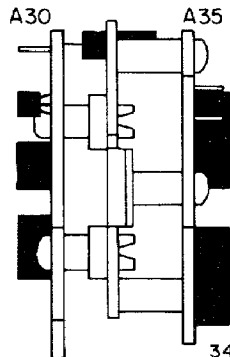

3490-B-4244

A30/A35

-hp- Part No. 03490-60313

U1 - U11

OPTICAL ISOLATORS

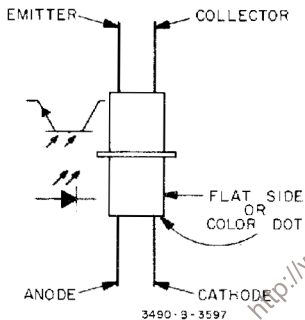

-hp- PART NO. 5080-9052
and
-hp- PART NO. 1990-0402

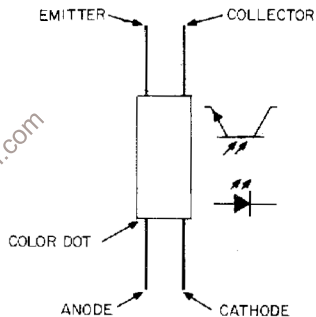

-hp- PART NO. 1990-0514

If an optical isolator is to be replaced, see Section VIII, Backdating, CHANGE NO. 9, Table 8-2 to determine correct Part No.

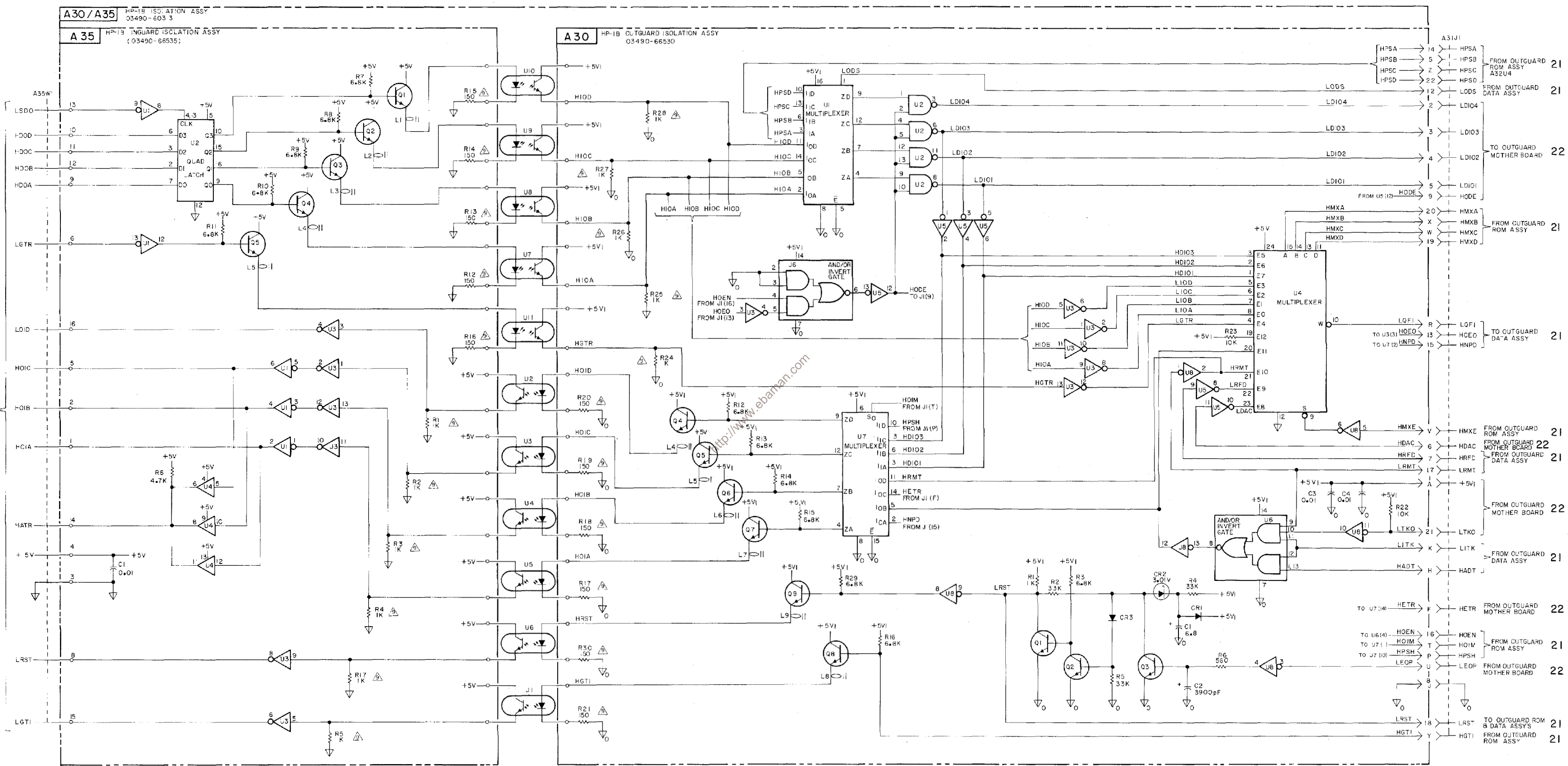
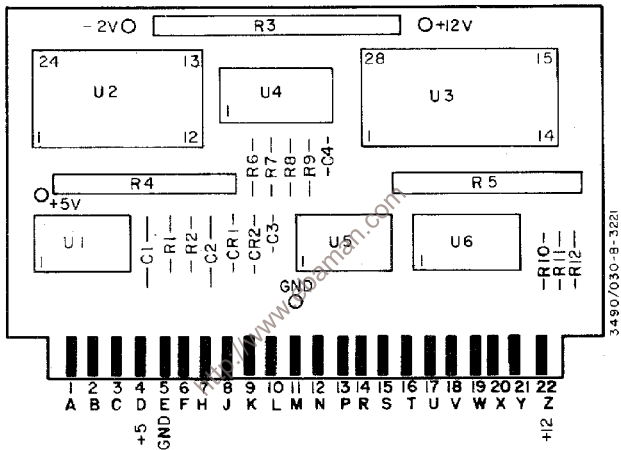

Figure 7-38. Schematic Diagram, HP-IB Isolation Assemblies, A30, A35.



3490/030-B-3221

A32

hp Part No. 03490-66532
Rev A

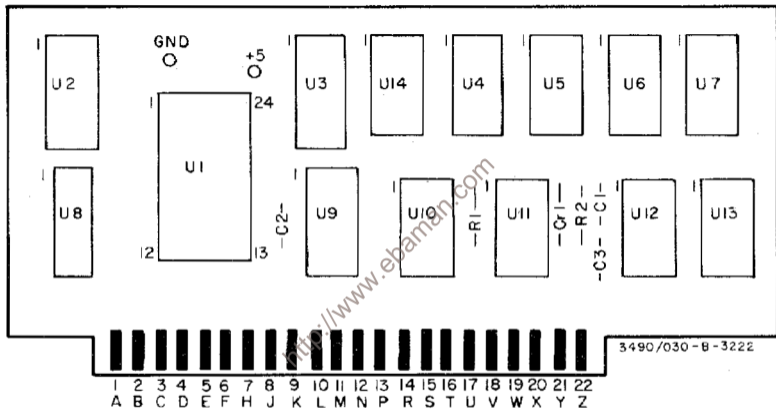

A33

hp Part No. 03490-66533

Rev A

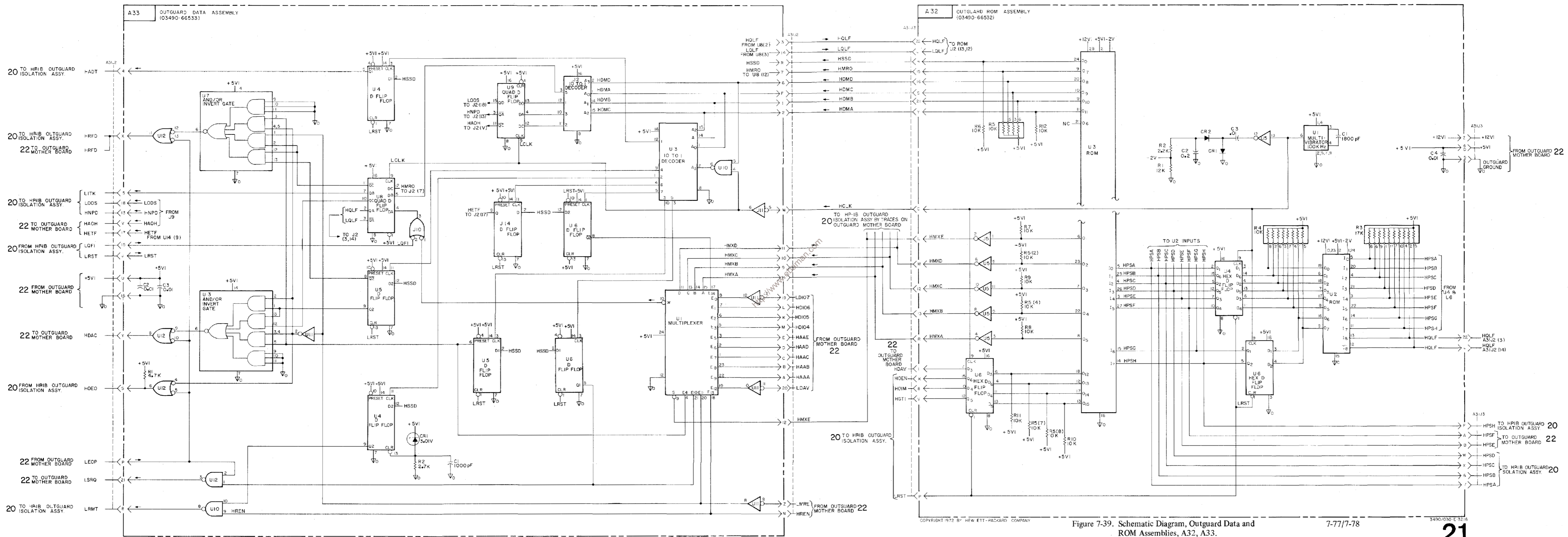

Figure 7-39. Schematic Diagram, Outguard Data and ROM Assemblies, A32, A33.

7-77/7-78

3490/030-E-3216

NOTES:

1. IF INSTRUMENT IS BEING PROGRAMMED EXTERNALLY BY HP-IB SYSTEM AND REFUSES TO SAMPLE VIA EXTERNAL TRIGGER SIGNAL, CHECK TO SEE IF JUMPER W11 IS IN PLACE.
2. THE HP-IB WAS PREVIOUSLY KNOWN AS THE GPIB. HP-IB MNEMONICS ARE NOTED AT THE HP-IB CONNECTOR, J12 (THE HP-IB USES LOW TRUE LOGIC). ALL INTERNAL CONNECTIONS OF THE 3490A MAINTAIN GPIB MNEMONICS. A CROSS-REFERENCE OF GPIB TO HP-IB MNEMONICS IS PROVIDED IN THE FOLLOWING TABLE 7-8.

TABLE 7-8. GPIB to HP-IB Cross-Reference.

HP-IB (LOW true logic)		GPIB (H preceding mnemonic means HIGH is true state; L preceding mnemonic means LOW is true state)
DIO1	Data Input/Output Bit 1	LDIO1
DIO2	Data Input/Output Bit 2	LDIO2
DIO3	Data Input/Output Bit 3	LDIO3
DIO4	Data Input/Output Bit 4	LDIO4
DIO5	Data Input/Output Bit 5	LDIO5
DIO6	Data Input/Output Bit 6	LDIO6
DIO7	Data Input/Output Bit 7	LDIO7
DIO8	Data Input/Output Bit 8	LDIO8
REN	Remote Enable	LREN
DAV	Data Valid	LDAV
NRFD	Not Ready For Data	HRFD
NDAC	Data Not Accepted	HDAC
IFC	Interface Clear	LEOP
SRQ	Service Request	LSRQ
ATN	Attention	LMRE

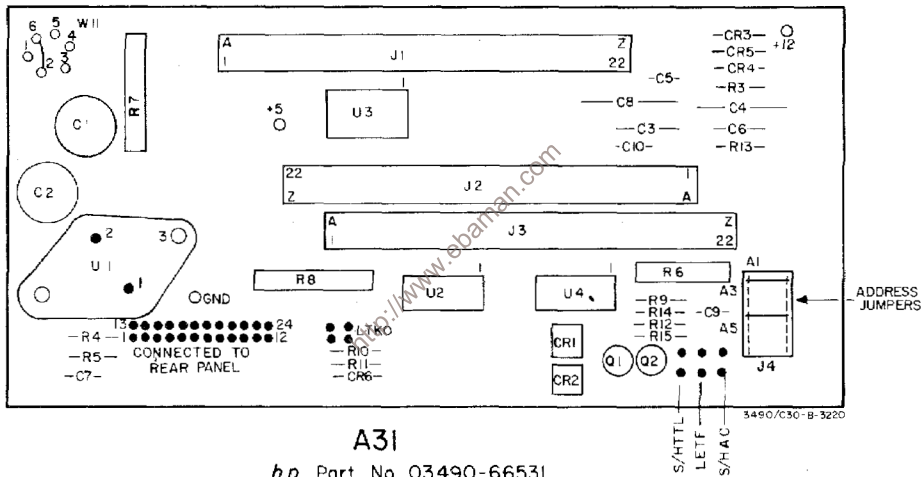

3490/C30-B-3220

A31

hp Part No. 03490-66531

Rev A

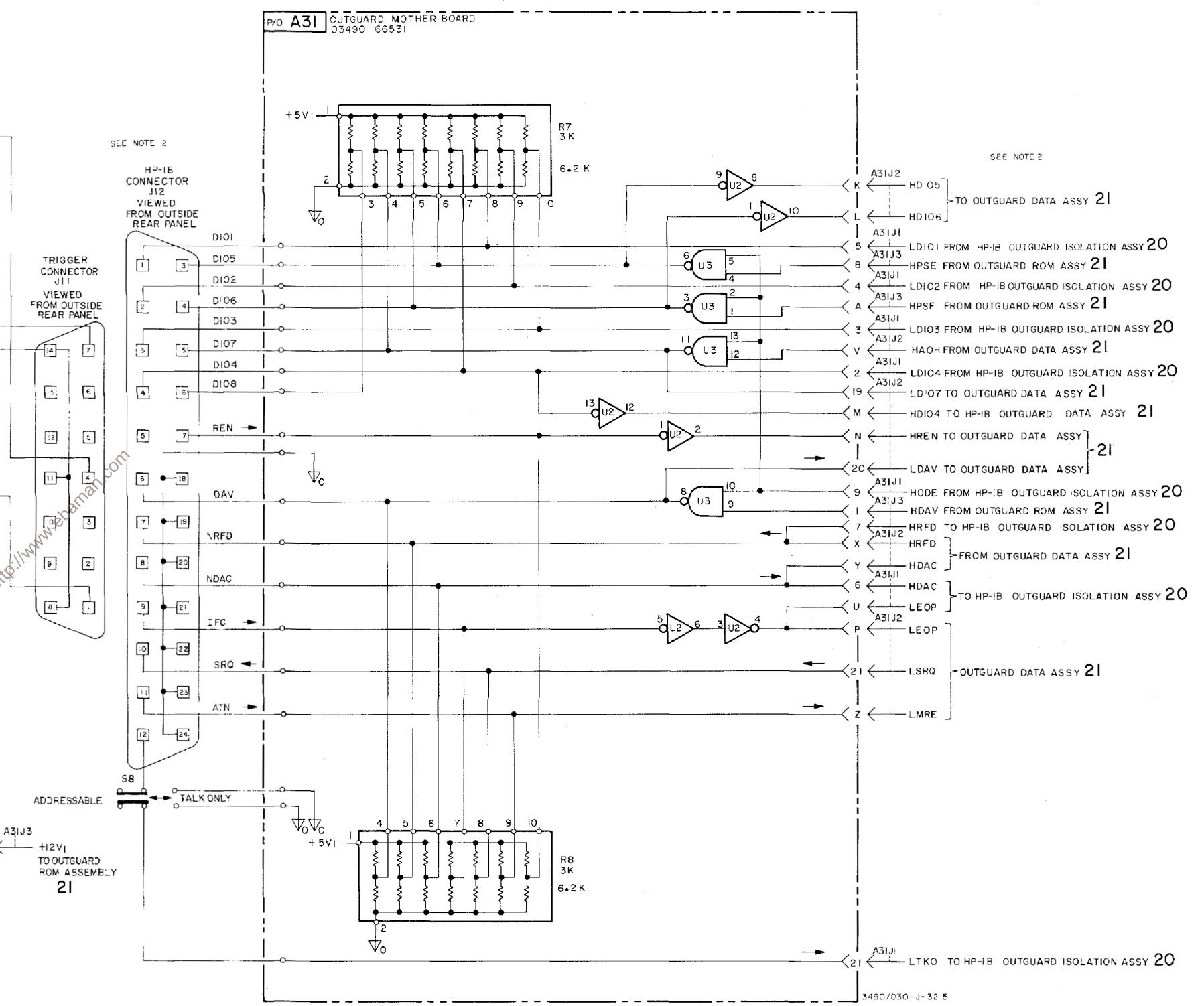
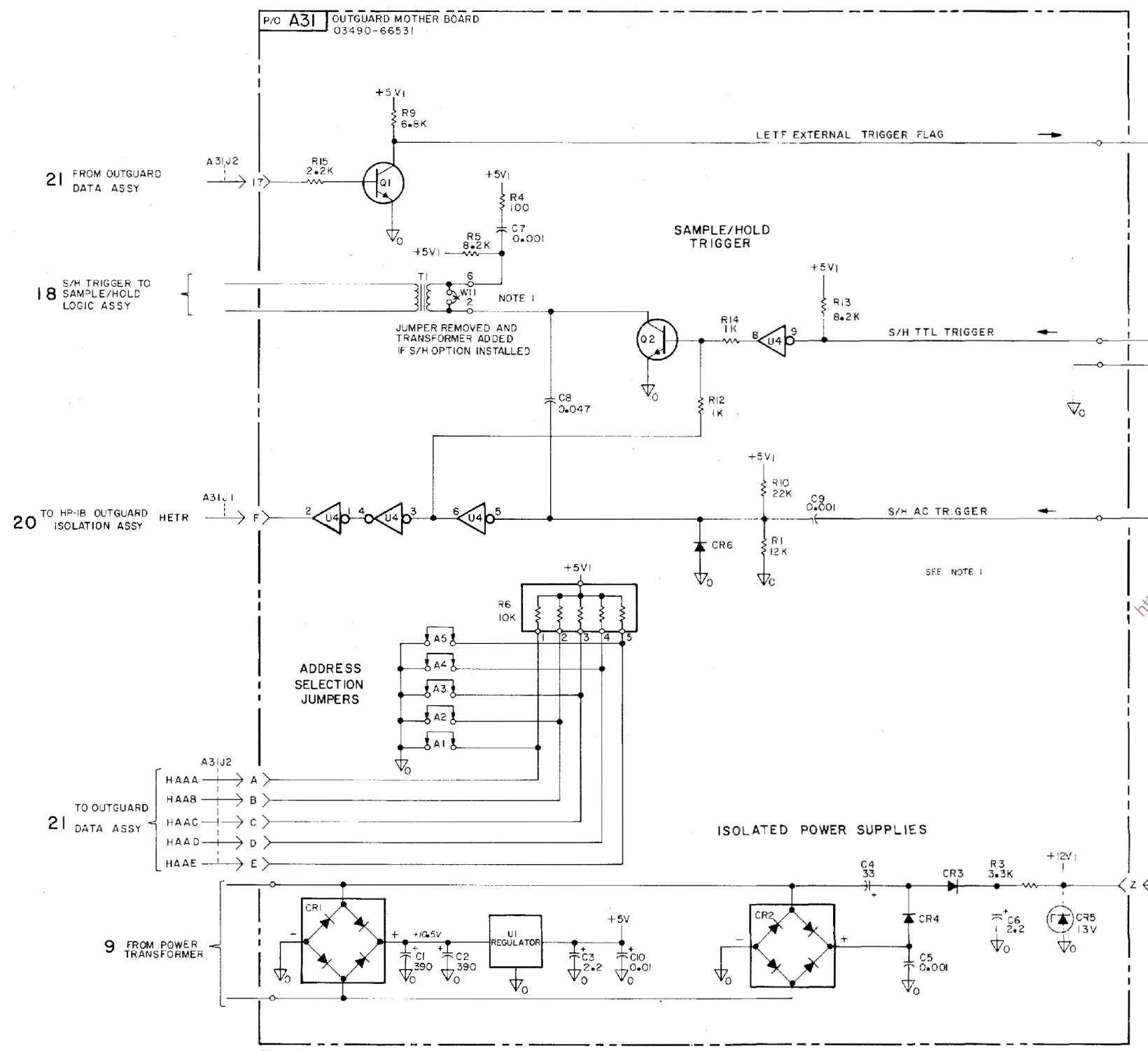

Figure 7-40. Schematic Diagram, Outguard Mother Board, A31. 7-79/7-80

SECTION VIII BACKDATING

8-1. INTRODUCTION.

8-2. This section contains backdating information which adapts this manual to instruments with serial numbers lower than that shown on the title page.

8-3. CHANGE SEQUENCE.

8-4. Changes are listed in the serial number order that they occurred in the manufacture of the instrument. However, in adapting this manual to an instrument with a particular serial number, apply the changes in reverse order. That is, begin with the latest change and progress to the earliest change that applies to the serial number in question. Table 8-1 lists the serial numbers to which each change applies.

Table 8-1. Manual Backdating Changes.

Instrument Serial Number	Make Manual Changes
1211A00130 and lower	18 through 1
1211A00180 and lower	18 through 2
1211A00255 and lower	18 through 3
1211A00655 and lower	18 through 4
1211A00805 and lower	18 through 6
1211A01005 and lower	18 through 7
1211A01155 and lower	18 through 8
All	18 through 9
1211A03045 and lower	18 through 10
1211A03344 and lower	18 through 11
1211A03415 and lower	18 through 12
1529A03415 and lower	18 through 13
1529A03485 and lower	18 through 14
1529A03905 and lower	18 through 15
1529A04065 and lower	18 through 16
1529A04235 and lower	18 through 17
1529A04595 and lower	18 through 18

8-5. PARTS NOT LISTED.

8-6. When replacing a part whose value or part number differs from the schematic diagram or parts list in this manual, yet is not listed in the following changes, use the replacement part number shown in Section VI.

1 CHANGE NO. 1 (for serial no. 1211A00130 and lower).

Table 6-1 and Schematic Diagram Figure 7-20
Change A1C502 to 0150-0093, 0.01 μ F

Table 6-1 and Figure 7-30
Change A7R5 to 0698-3154, 4220 Ω

Table 6-1 and Figure 7-31
Change A8C5 to 0160-0194, 0.015 μ F
Change A8R9, 10 to 0684-8221, 8.2 k Ω

2 CHANGE NO. 2 (for serial no. 1211A00180 and lower).

Table 6-1 and Schematic Diagram Figure 7-20
Delete A1C506, 507

3 CHANGE NO. 3 (for serial no. 1211A00255 and lower).

Table 6-1 and Figure 7-20

- Change A1C501 to 0160-0128, 2.2 μ F
- Change A1C502 to 0160-0820, 0.05 μ F
- Change A1C503 to 0140-0198, 200 pF
- Change A1C504 to 0150-0093, 0.01 μ F
- Change A1C505 to 0170-0040, 0.047 μ F
- Delete A1C508
- Change A1R111 to 0757-0397, 68.1 Ω 1/8 W
- Change A1R125 to 0757-0399, 82.5 Ω 1/8 W
- Change A1U102 to 1820-0223
- Change A1R511 to 0757-0280, 1 k Ω
- Change A1R519 to 0757-0410, 301 Ω
- Delete A1R525
- Delete A1R526
- Delete A1R527
- Delete A1R528
- Delete A2C5
- Delete A2R18

4 CHANGE NO. 4 (for serial no. 1211A00655 and lower).

Table 6-1

- Change A6C1 to 0160-0904, 0.05 μ F
- Change A7Q5 to 1853-0086
- Change A7R5 to 0757-0463, R: fxd 4320 Ω
- Add A7R8, 0684-1031, R: fxd 10 k Ω

Figure 7-30

Change K1 drive circuit as follows:

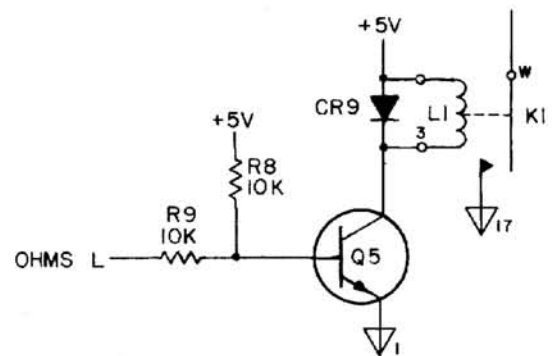

5 CHANGE NO. 5 (for serial no. 1211A00655 and lower)

Table 6-1

- Add A2C4, 0150-0122, C: fxd 2000 pF
- Add A2R14, 0757-0413, R: fxd flm 392 Ω 1 % 1/8 W
- Add A2R18, 0757-0442, R: fxd flm 10 k Ω 1 % 1/8 W
- Change A2U1 to 1820-0201

Figure 7-20

Add A2C4, A2R14 and A2R18 to A2U1 circuit as follows:

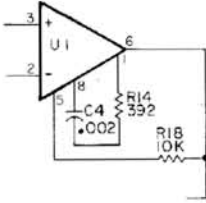

6 CHANGE NO. 6 (for serial no. 1211A00805 and lower)

Table 6-1

- Change A6C1 to 0160-0547, 0.04 μ F
- Change A11C3-5 to 15,000 pF 200 V part no. 0160-0194.
- Change A12C2 to 2000 pF 500 V part no. 0150-0122.
- Change A15A2R1-6 to 680 Ω part no. 0684-6811.
- Change A17A1R1, 4, 5 to 680 Ω part no. 0684-6811.

Figure 7-29

Change A6C1 to 0160-0547, 0.04 μ F

Figure 7-32

Change A15A2R1-6 to 680 Ω

Figure 7-33

- Change A11C3-5 to 15,000 pF
- Change A12C2 to 2000 pF
- Change A17A1R1, 4, 5 to 680 Ω

7 CHANGE NO. 7 (for serial no. 1211A01005 and lower)

Table 6-1 and Figure 7-30

- Change A7C5 to 0180-0401, 8 μ F
- Change A7C6 to 0160-0153, 0.001 μ F
- Change A7Q4 to 1853-0086
- Change A7R11 to 0684-1031, 10 k Ω
- Change A7U4 to 1820-0223

Figure 7-30

Connect center tap of T1 primary directly to + 5 V instead of Q4 collector.

8 CHANGE NO. 8 (for serial no. 1211A01155 and lower)

Beginning approximately with serial number 1211A01156, some printed circuit assemblies were revised to accommodate certain options or combinations of options. Some instruments with higher serial numbers may contain the previous revision of one or more of the following assemblies:

	Earlier Revision	Later Revision
A1	Rev. D	Rev. E
A3	Rev. A	Rev. B
A11	Rev. B	Rev. C

If your instrument contains one of the earlier revisions, use the following information applying to that assembly.

Table 6-1

- Delete A1C10
- Add A1C402, 0150-0071, C: fxd 400 pF
- Delete A1C403
- Change A1C501 to 0160-3813, 0.47 μ F
- Change A1C506, 507 to 0150-0084, 0.1 μ F
- Delete A1CR122, 123
- Change A1Q401, 408 to 1853-0010
- Change A1R430 to 0684-1541, 150 k Ω
- Change A1U102 to 1820-0478
- Delete A2C6 and A2L1, L2
- Delete A3R6 and A3U10
- Delete A11C6
- Add A11CR1, 1901-0040, Diode, Si
- Change A11R4 to 1810-0049, Resistor network 6.8 k Ω
- Delete A11R11
- Change A11U7, U12 to 1820-0979
- Change A11U8 to 1820-0976
- Change A11U9 to 1820-0583
- Change A11U10 to 1820-0616
- Change A11U11 to 1820-0710

Figure 7-20

- Add A1C402, 400 pF, between collector of A1Q427 and ground
- Delete A1C403
- Change A1C501 to 0.47 μ F
- Change A1C506, 507 to 0.1 μ F
- Change A1R430 to 150 k Ω
- Delete A2C6 and A2L1, L2

Figure 7-24

Delete A1C10

Figure 7-26

Delete CR122, 123 and connect pin 4 of U102 directly to - 24 V line

Figure 7-27

Delete R6, U10 and the two sections of U4 associated with the Sample/Hold Blanking circuit. Delete the Sample/Hold Mode input connection. Connect Data Bit A, C and D lines to DSI in the same manner as DS2 through DS6.

Figure 7-33

In those instruments having A11, Rev. B, substitute the A11 Schematic in Figure 8-1. Use the Component Location Drawing in Figure 8-2.

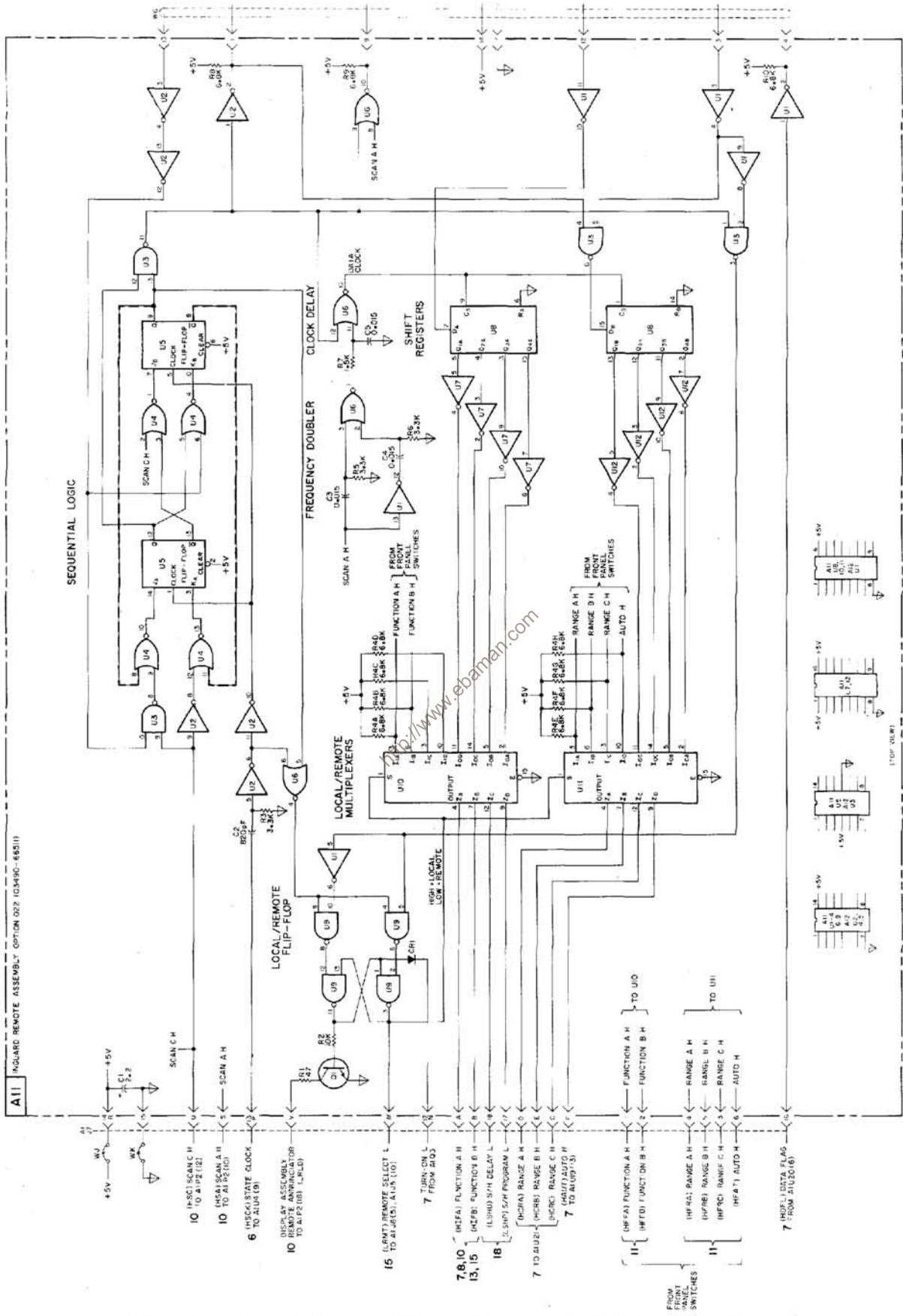

Figure 8-1. Schematic Diagram, A11 Assembly, Serial No. 1211A01155 and Lower.

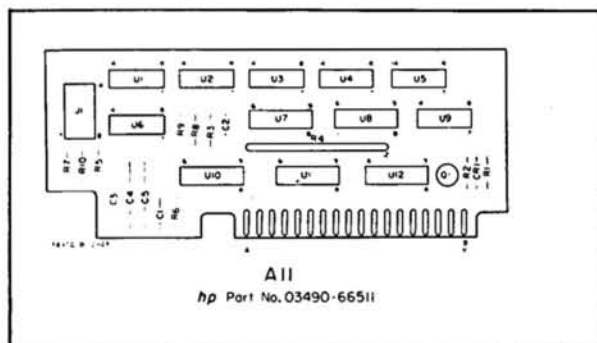

Figure 8-2. Component Location, A11, Serial No. 1211A01155 and Lower.

9 CHANGE NO. 9 (for ALL serial numbers)

Three types of optical isolators have been used in the 3490A. Figure 8-3 illustrates each type of isolator with its respective -hp- Part Number. Table 8-2 indicates each assembly containing optical isolators. The three types of optical isolators are listed along with their associated component changes. Optical isolators with different part numbers cannot be mixed in the 3490A. Replace optical isolators and associated components in accordance with Table 8-2

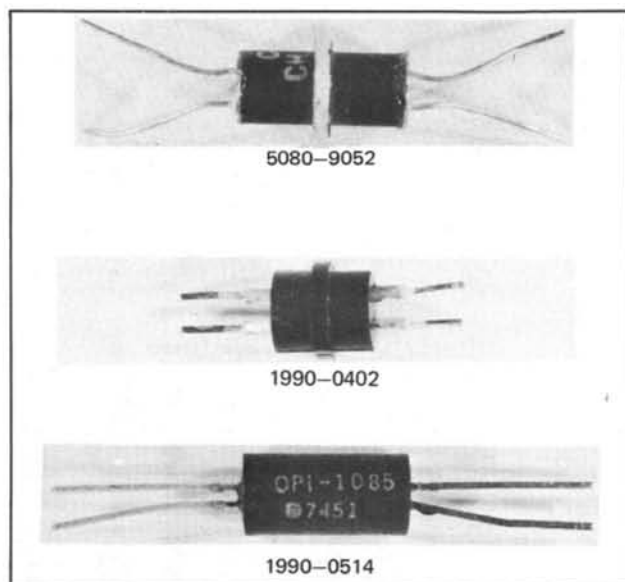

Figure 8-3. Optical Isolator Identification.

10 CHANGE NO. 10 (for Serial No. 1211A03045 and lower).

- Change A12C1 to 0160-0154, .0022 μ F.
- Change A12R2 to 0684-1521, 1500 ohms.
- Change A12U4 to 1820-0128.
- Add A12C2, 0150-0122, 2000 pF between A12U1(13) and ground.

Table 8-2. Optical Isolators and Associated Components.

Assembly Number	Reference Designator	-hp- Part Number and Description		
A22 (Schematic No. 14)	U1, U2 A22A2R1, R2	1990-0402 0684-4701 (47 Ω)	5080-9052 0684-4701 (47 Ω)	1990-0514 0683-1515 (150 Ω)
A15 (Schematic No. 15)	U1 thru U6 A15A1R1-6 A15A2R1-6	1990-0402 0684-4701 (47 Ω) 0684-6811 (680 Ω)	5080-9052 0684-4701 (47 Ω) 0698-4123 (499 Ω)	1990-0514 0683-1215 (120 Ω) 0698-4123 (499 Ω)
A12/A17 (Schematic No. 16)	U1 thru U6 A12C2** A12R6, R7 A17A1R1, 4, 5 A17A1R2, 3, 6 A17A2R1 A17A2R4, R5	1990-0402 0150-0122 (2000 pF) 0684-1031 (10 K) 0684-6811 (680 Ω) 0684-4701 (47 Ω) 0684-4701 (47 Ω) 0684-4701 (47 Ω)	5080-9052 0160-0157 (.0047 μ F)** 0684-1031 (10 K) 0698-4123 (499 Ω) 0684-4701 (47 Ω) 0684-4701 (47 Ω) 0684-4701 (47 Ω)	1990-0514 0150-0122 (2000 pF) 0683-6825 (6.8 K) 0684-6811 (680 Ω) 0683-1213 (120 Ω) 0683-1515 (150 Ω) 0683-1215 (120 Ω)
A30/A35 (Schematic No. 20)	U1 thru U11 A30R17-21, and R30 A30R24-26, and R28 A30R27 A35R1 A35F2-R5 and R17 A35R12-16 A35U1 (Hex Inverter)	1990-0402 0684-2211 (220 Ω) 0684-1521 (1.5 K) 0682-8215 (820 Ω) 0684-8211 (820 Ω) 0684-1521 (1.5 K) 0684-2211 (220 Ω) 1820-0586	5080-9052 0757-0400 (90.9 Ω) 0757-0414 (432 Ω) 0757-0414 (432 Ω) 0757-0414 (432 Ω) 0757-0414 (432 Ω) 0757-0400 (90.9 Ω) 1820-0174	1990-0514 0683-1515 (150 Ω) 0683-1025 (1 K) 0683-1025 (1 K) 0683-1025 (1 K) 0683-1025 (1 K) 0683-1515 (150 Ω) 1820-0174

**For Serial Numbers 1211A03046 and greater, delete A12C2.



CHANGE NO. 12 (for Serial No. 1211A03415 and lower).

Change the A3 Replaceable Parts List. See Table 8-3.

Table 8-3. A3 Replaceable Parts.

A3	03490-66503	1	BOARD ASSY:DISPLAY	28480	03490-66503
A3C1	0180-0197		C:FXD ELECT 2.2 UF 10% 20VDCW	56289	1500225X9020A2-DYS
A3C2	0180-0376	1	C:FXD ELECT 0.47 UF 10% 35VDCW	56289	1500474X9035A2-DYS
A3DS1	1990-0330	6	NUMERICAL DISPLAY:SOLID STATE	28480	1990-0330
A3DS2	1990-0330		NUMERICAL DISPLAY:SOLID STATE	28480	1990-0330
A3DS3	1990-0330		NUMERICAL DISPLAY:SOLID STATE	28480	1990-0330
A3DS4	1990-0330		NUMERICAL DISPLAY:SOLID STATE	28480	1990-0330
A3DS5	1990-0330		NUMERICAL DISPLAY:SOLID STATE	28480	1990-0330
A3DS6	1990-0330		NUMERICAL DISPLAY:SOLID STATE	28480	1990-0330
A3DS7	1990-0405	1	NUMERIC DISPLAY:LED(PLUS-MINUS)	28480	1990-0405
A3DS8	1990-0406	2	DIODE:VISIBLE LIGHT EMITTER	28480	1990-0406
A3DS9	1990-0406		DIODE:VISIBLE LIGHT EMITTER	28480	1990-0406
A3MP1	03490-24301	1	MASK:ANNUNCIATOR	28480	03490-24301
A3MP2	5040-5914	1	HOUSING:ANN	28480	5040-5914
A3MP3	7200-1271	1	HEAT SINK:DISPLAY	28480	7200-1271
A3MP4	1200-0462	1	SOCKET:IC CONTACT	00779	3-116141-2
A3R1	0684-7211	1	R:FXD COMP 220 OHM 10% 1/4W	01121	CB 7211
A3R2	0684-1011	5	R:FXD COMP 100 OHM 10% 1/4W	01121	CB 1011
A3R3	0684-1811		R:FXD COMP 180 OHM 10% 1/4W	01121	CB 1811
A3R4	0684-1811		R:FXD COMP 180 OHM 10% 1/4W	01121	CB 1811
A3R5	0684-4701	17	R:FXD COMP 47 OHM 10% 1/4W	01121	CB 4701
A3R6	0684-1531		R:FXD COMP 15K OHM 10% 1/4W	01121	CB 1531
A3U1	1820-0537	1	IC:TTL DUAL 4-INPUT NAND GATE	28480	1820-0537
A3U2	1820-0716	1	IC:TTL SYNC PRESET 4-BIT BINARY COUNTER	01295	SN74161M
A3U3	1820-0586		IC:TTL LP HEX INVERTER	12040	DM74L04M
A3U4	1820-0587	1	IC:TTL LP TRIPLE 3-INPUT NAND GATE	12040	DM74L10M
A3U5	1820-0627	3	IC:TTL LP BCD TO DEC. DECODER	07263	U7893L0159X
A3U6	1820-0054	4	IC:TTL QUAD 2-INPUT NAND GATE	01295	SN7400N
A3U7	1820-0054		IC:TTL QUAD 2-INPUT NAND GATE	01295	SN7400N
A3U8	1820-0583		IC:TTL LP QUAD 2-INPUT NAND GATE	12040	DM74L00N
A3U10	1820-0583		IC:TTL LP QUAD 2-INPUT NAND GATE	12040	DM74L00N
A3W3	03490-61601	1	CABLE ASSY:DISPLAY	28480	03490-61601

Change A3 Schematic Diagram, Component Locator and Troubleshooting tree. See Figure 8-6.

Change Paragraphs 4-70 thru 4-76 as follows:

4-70. DISPLAY ASSEMBLY (Figure 7-27).

4-71. Display Units.

4-72. Each of the six numerical display units contains a 4 x 7 dot matrix of light-emitting diodes (LEDs) to form the digits. In addition, each unit contains a decoding circuit to light the proper LEDs, and a latching circuit, so that the display can be changed only during an enable signal. Each unit also contains a decimal point to the left of the number. The polarity unit also contains the sample rate indicator. Each annunciator at the right side of the display is a single LED.

4-73. Scan Generator.

4-74. A relaxation oscillator operating at approximately 10 kHz provides the clock signal for the Scan Generator. The oscillator output drives a 4-bit synchronous counter.

The counter outputs are gated and fed back to reset the counter after every 12th input cycle, thus providing the proper combination of signals to the Scan Decoder. Three scan signals, A, B, and C, are applied to the Data Counter to release the stored BCD count information one digit at a time, beginning with the least significant digit, N1. These scan signals are also used in the Data Output and Remote circuits.

4-75. Scan Decoder.

4-76. The four signal outputs from the Scan Generator are fed into a 4-to-10 line decoder. The decoder then applies an enable pulse to each display unit at the same time that unit receives the BCD count information from the Data Counter. Scanning is continuous, with all six display units being scanned in approximately 1.6 ms, beginning with the least significant digit, N1.

Add A6C9, 0160-3622, 0.1 μ F

Delete A6C33

Delete A6C34

Delete A6C35

Delete A6R45

Delete A6U5

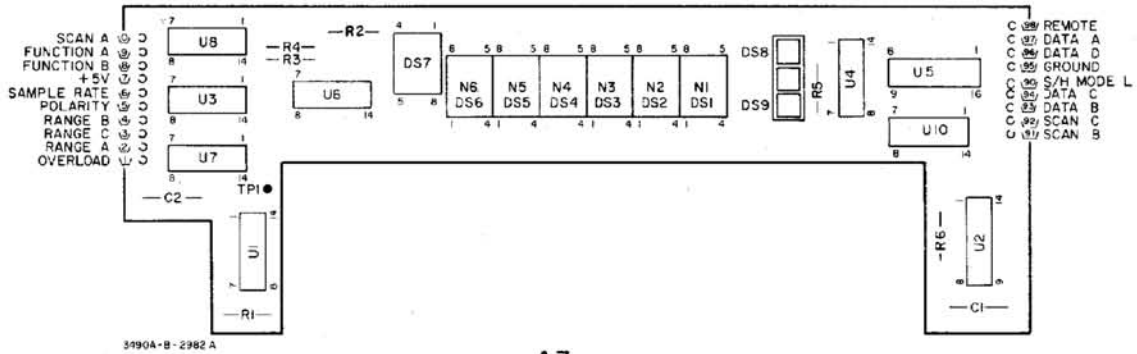

A3
hp Part No. 03490-66503
REV. B

BCD				Decimal Number
D	C	B	A	
L	L	L	L	0
L	L	L	H	1
L	L	H	L	2
L	L	H	H	3
L	H	L	L	4
L	H	L	H	5
L	H	H	L	6
L	H	H	H	7
H	L	L	L	8
H	L	L	H	9

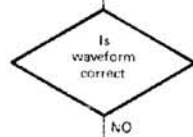
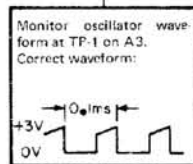
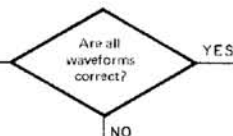
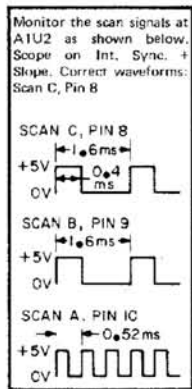

Replace A3U1

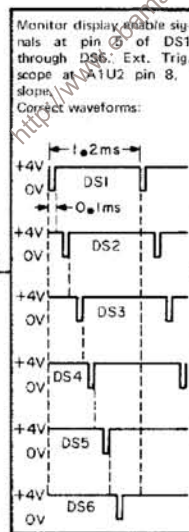

Replace A3U5

Troubleshoot display units DS1 through DS6 by substituting a known good unit for one which appears to be defective.

- NOTES:
1. If the 3490A has the special annunciator display, the assembly designation is A20. All A3 component designators also apply to the A20 assembly.
 2. An oscilloscope is required for these checks.

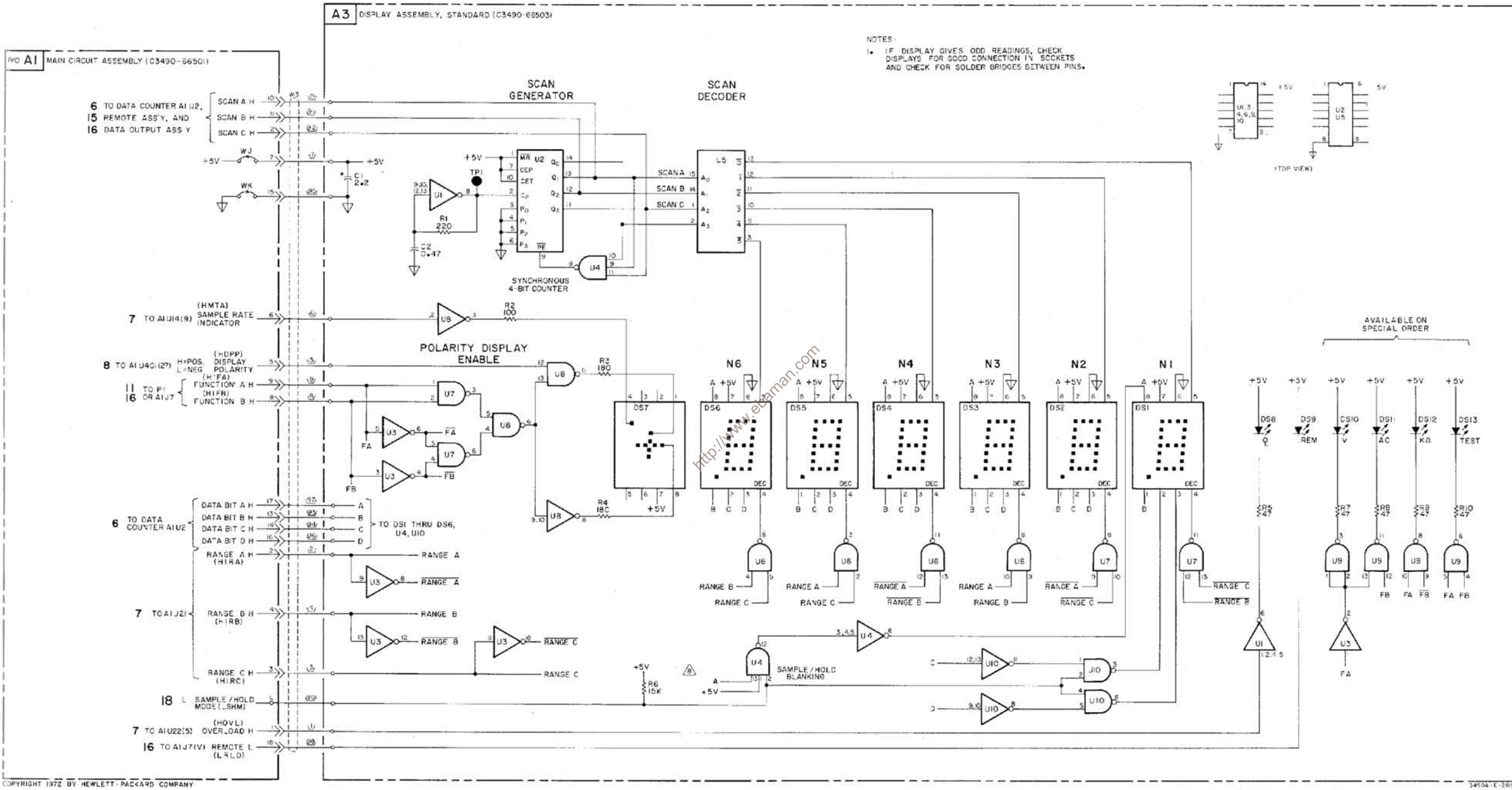

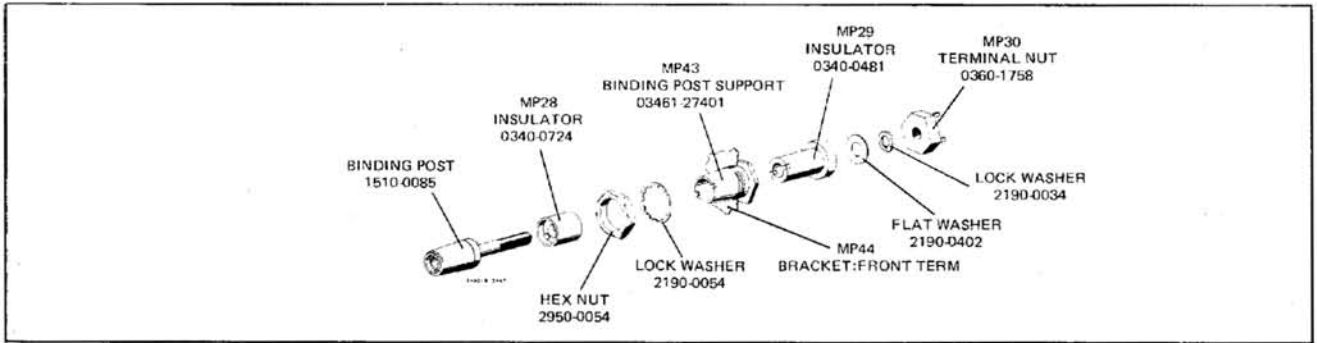

Figure 8-8. Binding Post Assembly.

13 CHANGE NO. 13 (for serial no. 1529A03415 and lower).

Table 6-1 and Schematic Diagram Figure 7-23
Change A1C12 to 0140-0200, 390 pF

Table 6-1, Chassis and Miscellaneous parts
Change part no. of J1 and J4 to 1510-0085
Delete J2 and J5
Change part no. of J3 to 1510-0086
Delete MP29
Change part no. of MP43 to 03461-24701
Change Binding Post Assembly drawing as shown

14 CHANGE NO. 14 (for serial no. 1529A03485 and lower).

Table 6-1 and Schematic Diagram Figure 7-24
Delete A1C13

15 CHANGE NO. 15 (for serial no. 1529A03905 and lower).

Table 6-1
Change part no. of the following twelve transistors to 1854-0087

A1Q403	Q412	Q421
Q405	Q414	Q423
Q407	Q416	Q425
Q410	Q418	Q427

Table 6-1 and Schematic Diagram Figure 7-31
Change A8C2, C3 and A29C1 to 0180-2511, 370 μ F

16 CHANGE NO. 16 (for serial no. 1529A04065 and lower).

Table 6-1
Change A3U6 - 8 to 1820-0621

Table 6-1 and Schematic Diagram Figure 7-27
Change R1 thru R15 to 0683-1215, 12 ohm
Change R16 to 0683-8205, 82 ohm
Change R17 to 0683-1215, 120 ohm

Table 6-1
Change A6K3 to 0490-1106

17 CHANGE NO. 17 (for serial no. 1529A04235 and lower).

Table 6-1 and Schematic Diagram Figure 7-27
Delete A3C2
Change A3R18 to 0683-1015, 100 ohm
Change A3CR1 to 1901-0040, .05A
Change A3U1 to 1820-1053
Change A3U3 to 1820-0586

18 CHANGE NO. 18 (for serial number 1376A04595 and lower).

Table 6-1
Change A1 to 66541
Add A1C301, 0150-0121, 0.1 μ F
Change A1C302 to 0180-0081, 50 μ F
Add A1C303, 0170-0040, 0.047 μ F
Delete A1C306, A1C307
Add A1CR301, 1902-0761
Add A1Q301, Q302, 1854-0071
Add A1Q303, 1854-0475
Add A1R301, 0757-0280, 1K
Add A1R302, 0698-3457, 316K
Add A1R303, 0811-9020, 1200K
Add A1R304, 0811-1335, 11K
Add A1R305, 0698-4518, 137K
Add A1R307, 0757-0439, 6.81K
Add A1R309, 0757-0441, 8.25K
Delete A1R322, R323, R324
Delete A1U302, U303
Change A1 Schematic Diagram and component locator. See Figure 8-9.

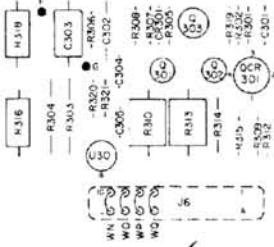

AI

hp Part No. 03490-66541

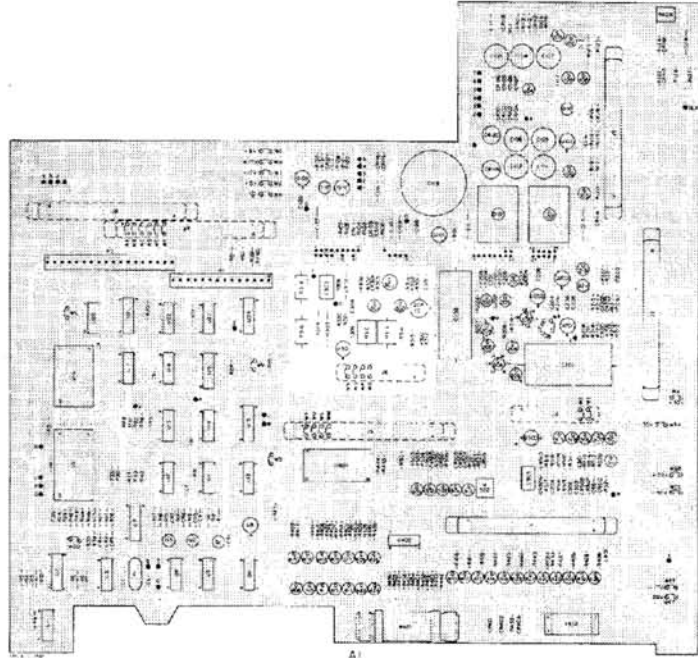

hp Part No. 03490-66541

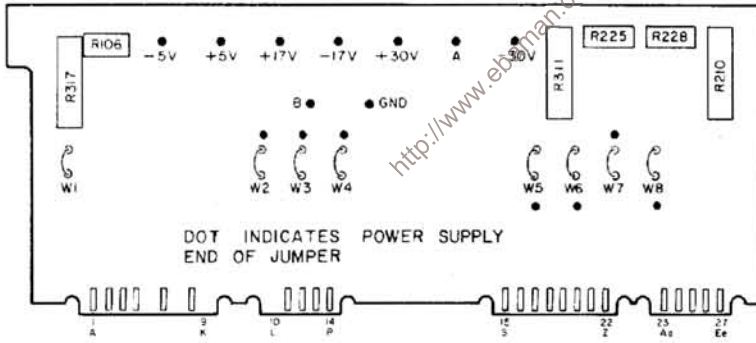

AIAI

hp Part No. 03490-66521

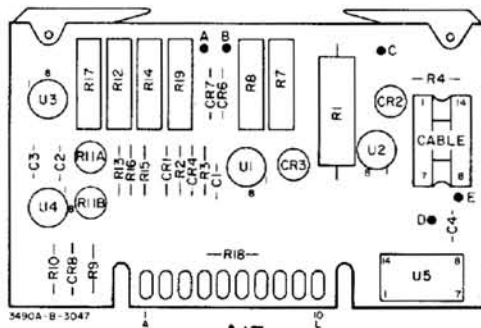

AI3

hp Part No. 03490-66513

CODE LIST OF MANUFACTURERS

The following code numbers are from the Federal Supply Code for Manufacturers Cataloging Handbooks H4-1 (Name to Code) and H4-2 (Code to Name) and their latest supplements. The date of revision and the date of the supplements used appear at the bottom of each page. Alphabetical codes have been arbitrarily assigned to suppliers not appearing in the H4 Handbooks.

Code No.	Manufacturer	Address	Code No.	Manufacturer	Address	Code No.	Manufacturer	Address
00000	U. S. A Common	Any supplier of U.S.	05347	Ultronix, Inc.	San Mateo, Cal.	11236	CTS of Berne, Inc.	Berne, Ind.
00136	McCoy Electronics	Mount Holly Springs, Pa.	05397	Union Carbine Corp., Elect.		11237	Chicago Telephone of California, Inc.	So. Pasadena, Cal.
00213	Sage Electronics Corp.	Rochester, N. Y.	05574	Viking Ind. Inc.	New York, N. Y.	11242	Bay State Electronics Corp.	Waltham, Mass.
00287	Cemco, Inc.	Danielson, Conn.	05593	Icore Electro-Plastics Inc.	Sunnyvale, Cal.	11312	Teledyne Inc., Microwave Div.	Palo Alto, Cal.
00334	Humidial	Colton, Calif.	05616	Cosmo Plastic (c/o Electrical Spec. Co.)	Cleveland, Ohio	11314	National Seal	Downey, Cal.
00348	Mictron, Co., Inc.	Valley Stream, N. Y.	05624	Barber Colman Co.	Rockford, Ill.	11453	Precision Connector Corp.	Jamaica, N. Y.
00373	Garlock Inc.	Cherry Hill, N. J.	05728	Tiffen Optical Co.	Roslyn Heights, Long Island, N. Y.	11534	Duncan Electronics Inc.	Costa Mesa, Cal.
00656	Aerovox Corp.	New Bedford, Mass.	05729	Metro-Tel Corp.	Westbury, N. Y.	11711	General Instrument Corp., Semiconductor Division Products Group	Newark, N. J.
00779	Amp. Inc.	Harrisburg, Pa.	05783	Stewart Engineering Co.	Santa Cruz, Cal.	11717	Imperial Electronic, Inc.	Buena Park, Cal.
00781	Aircraft Radio Corp.	Boonton, N. J.	05820	Wakefield Engineering Inc.	Wakefield, Mass.	11870	Melabs, Inc.	Palo Alto, Cal.
00809	Crown, Ltd.	Whitby, Ontario, Canada	06004	Bassick Co., Div. of Stewart Warner Corp.	Bridgeport, Conn.	12136	Philadelphia Handle Co.	Camden, N. J.
00815	Northern Engineering Laboratories, Inc.	Burlington, Wis.	06090	Raychem Corp.	Redwood City, Cal.	12361	Grove Mfg. Co., Inc.	Shady Grove, Pa.
00853	Sangamo Electric Co., Pickens Div.	Pickens, S. C.	06175	Bausch and Lomb Optical Co.	Rochester, N. Y.	12574	Gulton Ind. Inc., Data System Div.	Albuquerque, N. M.
00866	Goe Engineering Co.	City of Industry, Cal.	06402	E. T. A. Products Co. of America	Chicago, Ill.	12697	Clarostat Mfg. Co.	Dover, N. H.
00891	Carl E. Holmes Corp.	Los Angeles, Cal.	06540	Amatom Electronic Hardware Co., Inc.	New Rochelle, N. Y.	12728	Elmar Filter Corp.	W. Haven, Conn.
00929	Microlab Inc.	Livingston, N. J.	06555	Beede Electrical Instrument Co., Inc.	Penacook, N. H.	12859	Nippon Electric Co., Ltd.	Tokyo, Japan
01002	General Electric Co., Capacitor Dept.	Hudson Falls, N. Y.	06666	General Devices Co., Inc.	Indianapolis, Ind.	12881	Metex Electronics Corp.	Clark, N. J.
01009	Alden Products Co.	Brockton, Mass.	06751	Components Inc., Ariz. Div.	Phoenix, Arizona	12930	Delta Semiconductor Inc.	Newport Beach, Cal.
01121	Allen Bradley Co.	Milwaukee, Wis.	06812	Torrington Mfg. Co., West Div.	Van Nuys, Cal.	12954	Dickson Electronics Corp.	Scottsdale, Arizona
01255	Litton Industries, Inc.	Beverly Hills, Cal.	06980	Varian Assoc. Etmac Div.	San Carlos, Cal.	13019	Airco Supply Co., Inc.	Wichita, Kansas
01281	TRW Semiconductors, Inc.	Lawndale, Cal.	07088	Kelvin Electric Co.	Van Nuys, Cal.	13061	Wilco Products	Detroit, Mich.
01295	Texas Instruments, Inc., Transistor Products Div.	Dallas, Texas	07126	Digitran Co.	Pasadena, Cal.	13103	Thermolloy	Dallas, Texas
01349	The Alliance Mfg. Co.	Alliance, Ohio	07137	Transistor Electronics Corp.	Minneapolis, Minn.	13327	Solitron Devices Inc.	Tappan, N. Y.
01538	Small Parts Inc.	Los Angeles, Cal.	07138	Westinghouse Electric Corp., Electronic Tube Div.	Elmira, N. Y.	13396	Telefunken (GmbH)	Hanover, Germany
01589	Pacific Relays, Inc.	Van Nuys, Cal.	07149	Filmohm Corp.	New York, N. Y.	13835	Midland-Wright Div. of Pacific Industries, Inc.	Kansas City, Kansas
01670	Gudebrod Bros. Silk Co.	New York, N. Y.	07233	Cinch-Graphik Co.	City of Industry, Cal.	14099	Sem-Tech	Newbury Park, Cal.
01930	Aerocorp Corp.	Rockford, Ill.	07256	Siltron Transistor Corp.	Carle Place, N. Y.	14193	Calif. Resistor Corp.	Santa Monica, Cal.
01960	Pulse Engineering Co.	Santa Clara, Cal.	07261	Avnet Corp.	Culver City, Cal.	14298	American Components, Inc.	Conshohocken, Pa.
02114	Ferroxcube Corp. of America	Saugerties, N. Y.	07263	Fairchild Camera & Inst. Corp., Semiconductor Div.	Mountain View, Cal.	14433	ITT Semiconductor, a Div. of Int. Telephone and Telegraph Corporation	West Palm Beach, Fla.
02116	Wheelock Signals, Inc.	Long Branch, N. J.	07322	Minnesota Rubber Co.	Minneapolis, Minn.	14493	Hewlett-Packard Company	Loveland, Colo.
02286	Cole Rubber and Plastics Inc.	Sunnyvale, Cal.	07387	Bircher Corp., The	Monterey Park, Cal.	14655	Cornell Dublier Electric Corp.	Newark, N. J.
02660	Amphenol-Borg Electronics Corp.	Broadview, Ill.	07397	Sylvania Elect. Prod., Inc., Mt. View Operations	Mountain View, Cal.	14674	Corning Glass Works	Corning, N. Y.
02735	Radio Corp. of America, Semiconductor and Materials Division	Somerville, N. J.	07700	Technical Wire Products Inc.	Cranford, N. J.	14752	Electro Cube Inc.	San Gabriel, Cal.
02771	Vocaline Co. of America, Inc.	Old Saybrook, Conn.	07829	Bodine Elect. Co.	Chicago, Ill.	14960	Williams Mfg. Co.	San Jose, Cal.
02777	Hopkins Engineering Co.	San Fernando, Cal.	07910	Continental Device Corp.	Hawthorne, Cal.	15106	The Sphere Co., Inc.	Little Falls, N. J.
02875	Hudson Tool & Die	Newark, N. J.	07933	Raytheon Mfg. Co., Semiconductor Div.	Mountain View, Cal.	15203	Webster Electronics Co.	New York, N. Y.
03296	Nylon Molding Corp.	Springfield, N. J.	07980	Hewlett-Packard Co., New Jersey Division	Rockaway, N. J.	15287	Scionics Corp.	Northridge, Cal.
03508	G. E. Semiconductor Prod. Dept.	Syracuse, N. Y.	08145	U. S. Engineering Co.	Los Angeles, Cal.	15291	Adjustable Bushing Co.	N. Hollywood, Cal.
03705	Apex Machine & Tool Co.	Dayton, Ohio	08289	Blinn, Delbert Co.	Pomona, Cal.	15558	Micron Electronics	Garden City, Long Island, N. Y.
03797	Eldema Corp.	Compton, Calif.	08358	Burgess Battery Co.	Niagara Falls, Ontario, Canada	15566	Amprobe Inst. Corp.	Lybrook, N. Y.
03818	Parker Seal Co.	Los Angeles, Cal.	08524	Deutsch Fastener Corp.	Los Angeles, Cal.	15631	Cabletronics	Costa Mesa, Cal.
03877	Transitron Electric Corp.	Wakefield, Mass.	08664	Bristol Co., The	Waterbury, Conn.	15772	Twentieth Century Coil Spring Co.	Santa Clara, Cal.
03888	Pyrofilm Resistor Co., Inc.	Cedar Knolls, N. J.	08717	Sloan Company	Sun Valley, Cal.	15801	Fenwal Elect. Inc.	Framingham, Mass.
03954	Singer Co., Diehl Div., FINDERNE Plant	Sumerville, N. J.	08718	ITT Cannon Electric Inc., Phoenix Div.	Phoenix, Arizona	15818	Amelco Inc.	Mountain View, Cal.
04009	Arrow, Hart and Hegeman Elect. Co.	Hartford, Conn.	08727	National Radio Lab. Inc.	Paramus, N. J.	16037	Spruce Pine Mica Co.	Spruce Pine, N. C.
04013	Taruus Corp.	Lambertville, N. J.	08792	CBS Electronics Semiconductor Operations, Div. of CBS Inc.	Lowell, Mass.	16179	Omni-Spectra Inc.	Detroit, Ill.
04062	Arco Electronic Inc.	Great Neck, N. Y.	08806	General Electric Co., Miniature Lamp Dept.	Cleveland, Ohio	16352	Computer Diode Corp.	Lodi, N. J.
04217	Essex Wire	Los Angeles, Cal.	08984	Mel-Rain	Indianapolis, Ind.	16554	Electroid Co.	Union, N. J.
04222	Hi-Q Division of Aerovox	Myrtle Beach, S. C.	09026	Babcock Relays Div.	Costa Mesa, Cal.	16585	Boots Aircraft Nut Corp.	Pasadena, Cal.
04354	Precision Paper Tube Co.	Wheeling, Ill.	09097	Electronic Enclosures Inc.	Los Angeles, Calif.	16688	Ideal Prec. Meter Co., Inc., De Jur Meter Div.	Brooklyn, N. Y.
04404	Palo Alto Division of Hewlett-Packard Co.	Palo Alto, Cal.	09134	Texas Capacitor Co.	Houston, Texas	16758	Delco Radio Div. of G. M. Corp.	Kokomo, Ind.
04651	Sylvania Electric Products, Microwave Device Div.	Mountain View, Cal.	09145	Tech. Ind. Inc. Atohm Elect.	Burbank, Cal.	17109	Thermonetics Inc.	Canoga Park, Cal.
04673	Dakota Engr. Inc.	Culver City, Cal.	09250	Electro Assemblies, Inc.	Chicago, Ill.	17474	Tranex Company	Mountain View, Cal.
04713	Motorola Inc. Semiconductor Prod. Div.	Phoenix, Arizona	09353	C & K Components Inc.	Newton, Mass.	17675	Hamlin Metal Products Corp.	Akron, Ohio
04732	Filtern Co., Inc. Western Div.	Culver City, Cal.	09569	Mallory Battery Co. of Canada, Ltd.	Toronto, Ontario, Canada	17745	Angstrom Prec. Inc.	No. Hollywood, Cal.
04773	Automatic Electric Co.	Northlake, Ill.	09795	Pennsylvania Florocarbon Corp.	Clifton Heights, Penn.	17856	Siliconix Inc.	Sunnyvale, Cal.
04796	Sequoia Wire Co.	Redwood City, Cal.	09922	Burdny Corp.	Norwalk, Conn.	17870	McGraw-Edison Co.	Manchester, N. H.
04811	Precision Coil Spring Co.	El Monte, Cal.	10214	General Transistor Western Corp.	Los Angeles, Cal.	18042	Power Design Pacific Inc.	Palo Alto, Cal.
04870	P. M. Motor Company	Westchester, Ill.	10411	Ti-Tal, Inc.	Berkeley, Cal.	18083	Clevite Corp. Semiconductor Div.	Palo Alto, Cal.
04919	Component Mfg. Service Co.	W. Bridgewater, Mass.	10646	Carborundum Co.	Niagara Falls, N. Y.	18324	Signetics Corp.	Sunnyvale, Cal.
05006	Twentieth Century Plastics, Inc.	Los Angeles, Cal.				18476	Ty-Car Mfg. Co., Inc.	Holliston, Mass.
05277	Westinghouse Electric Corp. Semiconductor Dept.	Youngwood, Pa.				18486	TRW Elect. Comp. Div.	Des Plaines, Ill.

00015-49
Revised: May, 1970

From: Handbook Supplements
H4-1 Dated January 1970

CODE LIST OF MANUFACTURERS (Continued)

Code No.	Manufacturer	Address	Code No.	Manufacturer	Address	Code No.	Manufacturer	Address
19644	LRC Electronics	Horseheads, N. Y.	71482	C. P. Clare & Co.	Chicago, Ill.	78452	Thompson-Bremer & Co.	Chicago, Ill.
19701	Electra Mfg. Co.	Independence, Kansas	71590	Centralab Div. of	Globe Union Inc.	78471	Tilley Mfg. Co.	San Francisco, Cal.
20183	General Atomics Corp.	Philadelphia, Pa.	71616	Commercial Plastics Co.	Milwaukee, Wis.	78488	Stackpole Carbon Co.	St. Marys, Pa.
21226	Executone, Inc.	Long Island City, N. Y.	71700	Cornish Wire Co., The	New York, N. Y.	78493	Standard Thomson Corp.	Waltham, Mass.
21355	Fair Bearing Co., The	New Britain, Conn.	71707	Coto Coil Co., Inc.	Providence, R. I.	78553	Tinnerman Products, Inc.	Cleveland, Ohio
21520	Fansteel Metallurgical Corp.	N. Chicago, Ill.	71744	Chicago Miniature Lamp Works	Chicago, Ill.	78790	Transformer Engineers	San Gabriel, Cal.
23020	General Reed Co.	Metuchen, N. J.	71785	Cinch Mfg. Co.	Chicago, Ill.	78947	Ucinite Co.	Newtonville, Mass.
23042	Texscan Corp.	Indianapolis, Ind.	71984	Howard B. Jones Div.	Chicago, Ill.	79136	Waldes Kohinoor Inc.	Long Island City, N. Y.
23783	British Radio Electronics Ltd.	Washington, D.C.	72136	Dow Corning Corp.	Midland, Mich.	79142	Veeder Root, Inc.	Hartford, Conn.
24455	G. E. Lamp Division, Nela Park	Cleveland, Ohio	72619	Electro Motive Mfg. Co., Inc.	Willimantic, Conn.	79251	Wenco Mfg. Co.	Chicago, Ill.
24655	General Radio Co.	West Concord, Mass.	72619	Dialight Corp.	Brooklyn, N. Y.	79272	Continental-Wirt Electronics Corp.	Philadelphia, Pa.
24681	Memcor Inc., Comp. Div.	Huntington, Ind.	72656	Indiana General Corp.	Keasby, N. J.	79963	Zierick Mfg. Corp.	New Rochelle, N. Y.
26365	Gries Reproducer Corp.	New Rochelle, N. Y.	72699	General Instrument Corp., Cap Division	Newark, N. J.	80031	Mepeco Division of Sessions Clock Co.	Morrisstown, N. J.
26462	Grobert File Co. of America, Inc.	Carlstadt, N. J.	72765	Drake Mfg. Co.	Harwood Heights, Ill.	80033	Prestole Corp.	Toledo, Ohio
26651	Compac-Hollister Co.	Hollister, Cal.	72825	Hugh H. Eby Inc.	Philadelphia, Pa.	80120	Schnitzer Alloy Products Co.	Elizabeth, N. J.
26992	Hamilton Watch Co.	Lancaster, Pa.	72926	Gudemann Co.	Chicago, Ill.	80131	Electronic Industries Association.	Standard tube or semi-conductor device, any manufacturer.
28480	Hewlett-Packard Co.	Palo Alto, Cal.	72962	Elastic Stop Nut Corp.	Union, N. J.	80207	Unimax Switch, Div. Maxon Electronics Corp.	Wallingford, Conn.
28520	Heyman Mfg. Co.	Kenilworth, N. J.	72982	Robert M. Hadley Co.	Los Angeles, Cal.	80223	United Transformer Corp.	New York, N. Y.
30817	Instrument Specialties Co., Inc.	Little Falls, N. J.	73061	Erie Technological Products, Inc.	Erie, Pa.	80248	Oxford Electric Corp.	Chicago, Ill.
33173	G. E. Receiving Tube Dept.	Owensboro, Ky.	73076	Hansen Mfg. Co., Inc.	Princeton, Ind.	80294	Bourns Inc.	Riverside, Cal.
35434	Lectrohm Inc.	Chicago, Ill.	73136	H. M. Harper Co.	Chicago, Ill.	80411	Arco Div. of Robertshaw Controls Co.	Columbus, Ohio
36196	Stanwyck Coil Products, Ltd.	Hawkesbury, Ontario, Canada	73293	Helipot Div. of Deckman Inst., Inc.	Fullerton, Cal.	80486	All Star Products Inc.	Defiance, Ohio
36287	Cunningham, W. H. & Hill, Ltd.	Toronto, Ontario, Canada	73359	Hughes Products Division of Hughes Aircraft Co.	Newport Beach, Cal.	80509	Avery Label Co.	Monrovia, Cal.
37942	P. R. Mallory & Co., Inc.	Indianapolis, Ind.	73445	Amperex Elect. Co.	Hicksville, L. I., N. Y.	80583	Hammarlund Co., Inc.	Mars Hill, N. C.
39543	Mechanical Industries Prod. Co.	Akron, Ohio	73506	Bradley Semiconductor Corp.	New Haven, Conn.	80640	Stevens, Arnold, Co., Inc.	Boston, Mass.
40920	Miniature Precision Bearings, Inc.	Keene, N. H.	73559	Carling Electric, Inc.	Hartford, Conn.	80813	Dimeo Gray Co.	Dayton, Ohio
40931	Honeywell Inc.	Minneapolis, Minn.	73586	Circle F Mfg. Co.	Trenton, N. J.	81030	International Inst. Inc.	Orange, Conn.
42190	Muter Co.	Chicago, Ill.	73682	George K. Garrett Co., Div. MSL Industries, Inc.	Philadelphia, Pa.	81073	Grayhill Co.	LaGrange, Ill.
43990	C. A. Norgren Co.	Englewood, Colo.	73734	Federal Screw Products, Inc.	Chicago, Ill.	81095	Triad Transformer Corp.	Venice, Cal.
44655	Ohmite Mfg. Co.	Skokie, Ill.	73743	Fischer Special Mfg. Co.	Cincinnati, Ohio	81312	Winchester Elec. Div. Litton Ind., Inc.	Oakville, Conn.
46384	Penn Eng. & Mfg. Corp.	Doylestown, Pa.	73793	General Industries Co., The	Elyria, Ohio	81349	Military Specification	
47904	Polaroid Corp.	Cambridge, Mass.	73846	Goshen Stamping & Tool Co.	Goshen, Ind.	81483	International Rectifier Corp.	El Segundo, Cal.
48620	Precision Thermometer & Inst. Co.	Southampton, Pa.	73889	JFD Electronics Corp.	Brooklyn, N. Y.	81541	Airpax Electronics, Inc.	Cambridge, Maryland
49956	Microwave & Power Tube Div.	Waltham, Mass.	73905	Jennings Radio Mfg. Corp.	San Jose, Cal.	81860	Barry Controls, Div. Barry Wright Corp.	Watertown, Mass.
52090	Rowan Controller Co.	Westminster, Md.	73957	Groove-Pin Corp.	Ridgefield, N. J.	82042	Cartel Precision Electric Co.	Skokie, Ill.
52983	HP Co., Med. Elec. Div.	Waltham, Mass.	74276	Signalite Inc.	Neptune, N. J.	82047	Sperti Faraday Inc.	Copper Hewitt Electric Div. Hoboken, N. J.
54294	Shallcross Mfg. Co.	Seima, N. C.	74455	J. H. Winns, and Sons	Winchester, Mass.	82116	Electric Regulator Corp.	Norwalk, Conn.
55026	Simpson Electric Co.	Chicago, Ill.	74861	Industrial Condenser Corp.	Chicago, Ill.	82142	Jefferis Electronics Division of Speer Carbon Co.	Du Bois, Pa.
55933	Sonotone Corp.	Elmsford, N. Y.	74868	R. F. Products Division of Amphenol-Borg Electronic Corp.	Danbury, Conn.	82170	Fairchild Camera & Inst. Corp., Space & Defense Systems Div.	Paramus, N. J.
55938	Raytheon Co. Commercial Apparatus & System Div.	So. Norwalk, Conn.	74970	E. F. Johnson Co.	Waseca, Minn.	82209	Magurie Industries, Inc.	Greenwich, Conn.
56137	Spaulding Fibre Co., Inc.	Tonawanda, N. Y.	75042	International Resistance Co.	Philadelphia, Pa.	82219	Sylvania Electric Prod., Inc. Electronic Tube Division	Emporium, Pa.
56289	Sprague Electric Co.	North Adams, Mass.	75263	Keystone Carbon Co., Inc.	St. Marys, Pa.	82376	Astron Corp.	East Newark, Harrison, N. J.
58474	Superior Elect. Co.	Bristol, Conn.	75378	CTS Knights, Inc.	Sandwich, Ill.	82389	Switchcraft, Inc.	Chicago, Ill.
59446	Telex Corp.	Tulsa, Okla.	75382	Kulka Electric Corp.	Mt. Vernon, N. Y.	82647	Metals & Controls Inc., Spencer Products	Attleboro, Mass.
59730	Thomas & Betts Co.	Elizabeth, N. J.	75818	Leop Electric Mfg. Co.	Chicago, Ill.	82768	Phillips-Advance Control Co.	Joliet, Ill.
60741	Triplet Electrical Inst. Co.	Bluffton, Ohio	75915	Littelite, Inc.	Des Plaines, Ill.	82866	Research Products Corp.	Madison, Wis.
61775	Union Switch and Signal Div. of Westinghouse Air Brake Co.	Pittsburgh, Pa.	76005	Lord Mfg. Co.	Erie, Pa.	82877	Rolton Mfg. Co., Inc.	Woodstock, N. Y.
62119	Universal Electric Co.	Owosso, Mich.	76210	C. W. Marwedel	San Francisco, Cal.	82893	Vector Electronic Co.	Glendale, Cal.
63743	Ward-Leonard Electric Co.	Mt. Vernon, N. Y.	76433	General Instrument Corp., Micamold Division	Newark, N. J.	83058	Carr Fastener Co.	Cambridge, Mass.
64959	Western Electric Co., Inc.	New York, N. Y.	76487	James Millen Mfg. Co., Inc.	Malden, Mass.	83086	New Hampshire Ball Bearing, Inc.	Peterborough, N. H.
65092	Weston Inst. Inc.	Weston-Newark, Newark, N. J.	76493	J. W. Miller Co.	Los Angeles, Cal.	83125	General Instrument Corp., Capacitor Div.	Darlington, S. C.
66295	Wittek Mfg. Co.	Chicago, Ill.	76530	Fastener Corp., Div. of United Carr	San Leandro, Cal.	83148	ITT Wire and Cable Div.	Los Angeles, Cal.
66346	Minnesota Mining & Mfg. Co., Revere Mincom Div.	St. Paul, Minn.	76545	Mueller Electric Co.	Cleveland, Ohio	83186	Victory Eng. Corp.	Springfield, N. J.
70276	Allen Mfg. Co.	Hartford, Conn.	76703	National Union	Newark, N. J.	83298	Bendix Corp., Red Bank Div.	Red Bank, N. J.
70309	Allied Control	New York, N. Y.	76854	Oak Manufacturing Co.	Crystal Lake, Ill.	83315	Hubbell Corp.	Mundelein, Ill.
70318	Allmetal Screw Product Co., Inc.	Garden City, N. Y.	77068	The Bendix Corp., Electrodynamic Div.	N. Hollywood, Cal.	83324	Rosan Inc.	Newport Beach, Cal.
70417	Amplex, Div. of Chrysler Corp.	Detroit, Mich.	77075	Pacific Metals Co.	San Francisco, Cal.	83330	Smith, Herman H., Inc.	Brooklyn, N. Y.
70485	Atlantic India Rubber Works, Inc.	Chicago, Ill.	77221	Phaostroan Instrument and Electronic Co.	So. Pasadena, Cal.	83332	Tech Labs	Palisades Park, N. J.
70563	Amperite Co., Inc.	Union City, N. J.	77252	Philadelphia Steel and Wire Corp.	Philadelphia, Pa.	83385	Central Screw Co.	Chicago, Ill.
70674	ADC Products Inc.	Minneapolis, Minn.	77342	American Machine & Foundry Co., Potter & Brumfield Div.	Princeton, Ind.	83501	Gavitt Wire and Cable Co., Div. of Amerace Corp.	Brookfield, Mass.
70903	Belden Mfg. Co.	Chicago, Ill.	77630	TRW Electronic Components Div.	Camden, N. J.	83594	Burrughs Corp., Electronic Tube Div.	Plainfield, N. J.
70998	Bird Electric Corp.	Cleveland, Ohio	77638	General Instrument Corp., Rectifier Division	Brooklyn, N. Y.	83740	Union Carbide Corp., Consumer Prod. Div.	New York, N. Y.
71002	Birnbach Radio Co.	New York, N. Y.	77764	Resistance Products Co.	Harrisburg, Pa.	83777	Model Eng. and Mfg., Inc.	Huntington, Ind.
71034	Bliley Electric Co., Inc.	Erie, Pa.	77968	Rubbercraft Corp. of Calif.	Torrance, Cal.	83821	Loyd Scruggs Co.	Festus, Mo.
71041	Boston Gear Works Div. of Murray Co. of Texas	Quincey, Mass.	78189	Shakeproof Division of Illinois Tool Works	Elgin, Ill.	83942	Aeronautical Inst. & Radio Co.	Lodi, N. J.
71218	Bud Radio, Inc.	Willoughby, Ohio	78277	Sigma	So. Braintree, Mass.	84171	Arco Electronics Inc.	Great Neck, N. Y.
71279	Cambridge Thermionics Corp.	Cambridge, Mass.	78283	Signal Indicator Corp.	New York, N. Y.	84396	A. J. Glesener Co., Inc.	San Francisco, Cal.
71286	Camloc Fastener Corp.	Paramus, N. J.	78290	Struthers-Dunn Inc.	Pitman, N. J.	84411	TRW Capacitor Div.	Ogallala, Neb.
71313	Cardwell Condenser Corp.	Lindenhurst, L. I., N. Y.						
71400	Bussmann Mfg. Div. of McGraw-Edison Co.	St. Louis, Mo.						
71436	Chicago Condenser Corp.	Chicago, Ill.						
71447	Calif. Spring Co., Inc.	Pico-Rivera, Cal.						
71450	CTS Corp.	Elkhart, Ind.						
71468	ITT Cannon Electric Inc.	Los Angeles, Cal.						
71471	Cinema, Div. Aerovox Corp.	Burbank, Cal.						

00015-49
Revised: May, 1970

From: Handbook Supplements
114-1 Dated January 1970

CODE LIST OF MANUFACTURERS (Continued)

Code No.	Manufacturer	Address	Code No.	Manufacturer	Address	Code No.	Manufacturer	Address
94870	Sarkes Tarzian, Inc.	Bloomington, Ind.	91929	Honeywell Inc., Micro Switch Division	Freeport, Ill.	96095	Hi-Q Div. of Aerovox Corp.	Olean, N. Y.
85454	Boonton Molding Company	Boonton, N. J.	91961	Nahm-Bros. Spring Co.	Oakland, Cal.	96256	Thordarson-Meissner Inc.	Mt. Carmel, Ill.
85471	A. B. Boyd Co.	San Francisco, Cal.	92180	Tru-Connector Corp.	Peabody, Mass.	96296	Solar Mfg. Co.	Los Angeles, Cal.
85474	R. M. Bracamonte & Co.	San Francisco, Cal.	92367	Elgeet Optical Co., Inc.	Rochester, N. Y.	96396	Microswitch, Div. of	
85660	Koiled Kords, Inc.	Hamden, Conn.	92607	Tensolite Insulated Wire Co., Inc.	Tarrytown, N. Y.		Minn.-Honeywell	Freeport, Ill.
85911	Seamless Rubber Co.	Chicago, Ill.	92702	IMC Magnetics Corp.	Westbury, L. I., N. Y.	96330	Carlton Screw Co.	Chicago, Ill.
86174	Falnir Bearing Co.	Los Angeles, Calif.	92966	Hudson Lamp Co.	Kearney, N. J.	96341	Microwave Associates, Inc.	Burlington, Mass.
86197	Clifton Precision Products Co., Inc.	Clifton Heights, Pa.	93332	Sylvania Electric Prod. Inc., Semiconductor Div.	Woburn, Mass.	96501	Excel Transformer Co.	Oakland, Cal.
86579	Precision Rubber Products Corp.	Dayton, Ohio	93369	Robbins & Myers Inc.	Pallisades Park, N. J.	96508	Xcelite, Inc.	Orchard Park, N. Y.
86684	Radio Corp. of America, Electronic Comp. & Devices Division	Harrison, N. J.	93410	Stemco Controls, Div. of Essex Wire Corp.	Mansfield, Ohio	96733	San Fernando Elec. Mfg. Co.	San Fernando, Cal.
86928	Seastrom Mfg. Co.	Glendale, Cal.	93632	Waters Mfg. Co.	Culver City, Cal.	96881	Thomson Ind. Inc.	Long Island, N. Y.
87034	Marco Industries	Anaheim, Cal.	93929	G. V. Controls	Livingston, N. J.	97464	Industrial Retaining Ring Co.	Irvington, N. J.
87216	Philco Corporation (Lansdale Division)	Lansdale, Pa.	94137	General Cable Corp.	Bayonne, N. J.	97539	Automatic & Precision Mfg.	Englewood, N. J.
87473	Western Fibrous Glass Products Co.	San Francisco, Cal.	94144	Raytheon Co., Comp. Div., Ind. Comp. Operations	Quincy, Mass.	97979	Reon Resistor Corp.	Yonkers, N. Y.
87664	Van Waters & Rogers Inc.	San Francisco, Cal.	94148	Scientific Electronics Products, Inc.	Loveland, Colo.	97983	Litton System Inc., Adler-Westrex Commun. Div.	New Rochelle, N. Y.
87930	Tower Mfg. Corp.	Providence, R. I.	94154	Wagner Elect. Corp., Tung-Sol Div.	Newark, N. J.	98141	R-Tronics, Inc.	Jamaica, N. Y.
88140	Cutler-Hammer, Inc.	Lincoln, Ill.	94197	Curtiss-Wright Corp., Electronics Div.	East Patterson, N. J.	98159	Rubber Teck, Inc.	Gardena, Cal.
88220	Gould-National Batteries, Inc.	St. Paul, Minn.	94222	South Chester Corp.	Chester, Pa.	98220	Hewlett-Packard Co., Medical Elec. Div.	Pasadena, Cal.
88698	General Mills, Inc.	Buffalo, N. Y.	94330	Wire Cloth Products, Inc.	Bellwood, Ill.	98278	Microdot, Inc.	So. Pasadena, Cal.
89231	Graybar Electric Co.	Oakland, Cal.	94375	Automatic Metal Products Co.	Brooklyn, N. Y.	98291	Sealectro Corp.	Mamaroneck, N. Y.
89479	G. E. Distributing Corp.	Schenectady, N. Y.	94682	Worcester Pressed Aluminum Corp.	Worcester, Mass.	98376	Zero Mfg. Co.	Burbank, Cal.
89479	Security Co.	Detroit, Mich.	94696	Magnecraft Electric Co.	Chicago, Ill.	98410	Etc. Inc.	Cleveland, Ohio
89665	United Transformer Co.	Chicago, Ill.	95023	George A. Philbrick Researchers, Inc.	Boston, Mass.	98731	General Mills Inc., Electronics Div.	Minneapolis, Minn.
90030	United Shoe Machinery Corp.	Beverly, Mass.	95146	Alco Elect. Mfg. Co.	Lawrence, Mass.	98734	Paeco Division of Hewlett-Packard Co.	Palo Alto, Cal.
90179	U. S. Rubber Co., Consumer Ind. & Plastics Prod. Div.	Passaic, N. J.	95236	Allies Products Corp.	Dania, Fla.	98821	North Hills Electronics, Inc.	Glen Cove, N. Y.
90365	Belleville Specialty Tool Mfg. Inc.	Belleville, Ill.	95238	Continental Connector Corp.	Woodside, N. Y.	98978	International Electronic Research Corp.	Burbank, Cal.
90763	United Carr Fastener Corp.	Chicago, Ill.	95263	Leecraft Mfg. Co., Inc.	Long Island, N. Y.	99109	Columbia Technical Corp.	New York, N. Y.
90970	Bearing Engineering Co.	San Francisco, Cal.	95265	National Coil Co.	Sheridan, Wyo.	99313	Varian Associates	Palo Alto, Cal.
91146	ITT Cannon Elect. Inc., Salem Div.	Salem, Mass.	95275	Vitramon, Inc.	Bridgeport, Conn.	99378	Altee Corp.	Winchester, Mass.
91260	Connor Spring Mfg. Co.	San Francisco, Cal.	95348	Gordos Corp.	Bloomfield, N. J.	99515	Marshall Ind., Capacitor Div.	Monrovia, Cal.
91345	Miller Dial & Nameplate Co.	El Monte, Cal.	95354	Method Mfg. Co.	Rolling Meadows, Ill.	99707	Control Switch Division, Controls Co. of America	El Segundo, Cal.
91418	Radio Materials Co.	Chicago, Ill.	95566	Arnold Engineering Co.	Marengo, Ill.	99800	Delevan Electronics Corp.	East Aurora, N. Y.
91506	Augat Inc.	Attleboro, Mass.	95712	Dage Electric Co., Inc.	Franklin, Ind.	99848	Wilco Corporation	Indianapolis, Ind.
91637	Dale Electronics, Inc.	Columbus, Nebr.	95984	Siemon Mfg. Co.	Wayne, Ill.	99928	Branson Corp.	Whippany, N. J.
91662	Elco Corp.	Willow Grove, Pa.	95987	Weckesser Co.	Chicago, Ill.	99934	Rembrandt, Inc.	Boston, Mass.
91673	Epiphone Inc.	New York, N. Y.	96067	Microwave Assoc. West, Inc.	Sunnyvale, Cal.	99942	Hoffman Electronics Corp., Semiconductor Division	El Monte, Cal.
91737	Gremer Mfg. Co., Inc.	Wakefield, Mass.				99957	Technology-Instrument Corp. of California	Newbury Park, Cal.
91827	K F Development Co.	Redwood City, Cal.						
91886	Malco Mfg., Inc.	Chicago, Ill.						

The following HP Vendors have no number assigned in the latest supplement to the Federal Supply Code for Manufacturers Handbook.

0000F	Malco Tool and Die	Los Angeles, Calif.	000CS	Hewlett-Packard Co., Colorado Springs Div.	Colorado Springs, Colorado	000QQ	Cooltron	Oakland, Cal.
0000Z	Willow Leather Products Corp.	Newark, N. J.	000MM	Rubber Eng. & Development	Hayward, Cal.	000WW	California Eastern Lab	Burlington, Cal.
000AB	ETA	England	000NN	A "N" D Mfg. Co.	San Jose, Cal.	000YY	S. K. Smith Co.	Los Angeles, Cal.
000BB	Precision Instrument Comp. Co.	Van Nuys, Cal.						

ELECTRONIC

SALES & SERVICE OFFICES

UNITED STATES

ALABAMA
2250 Altheimburg Dr., S.E.
P.O. Box 4207
Munfordville 35802
Tel: (205) 881-4581
TWX: 810-726-2204

ARIZONA
2336 F. Maggolin St.
Phoenix 85034
Tel: (602) 244-1163
TWX: 910-951-1330

5737 East Broadway
Tucson 85711
Tel: (602) 298-2313
TWX: 910-952-1152
Effective Dec. 10, 1973:
2421 East Aragon Rd.
Tucson 85706
Tel: (602) 888-4861

CALIFORNIA
1430 East OrangeBorpe Ave.
Fullerton 92631
Tel: (714) 870-1000
TWX: 910-592-1288

1022 Alkeshim Boulevard
North Hollywood 91604
Tel: (213) 872-1282
TWX: 910-499-2170

5305 Arizona Place
Los Angeles 90045
Tel: (213) 640-2518
TWX: 910-322-9148

1101 Embarcadero Road
Palo Alto 94303
Tel: (415) 327-6530
TWX: 910-373-1280

2220 Watt Ave.
Sacramento 95825
Tel: (916) 482-1463
TWX: 910-367-2092

9606 Aero Drive
P.O. Box 23333
San Diego 92123
Tel: (714) 279-3400
TWX: 910-335-2000

1101 Embarcadero Road
Palo Alto 94303
Tel: (415) 327-6530
TWX: 910-373-1280

COLORADO
7805 East Pentstee
Englewood 80110
Tel: (303) 777-3355
TWX: 910-935-0705

CONNECTICUT
12 Lunar Drive
New Haven 06525
Tel: (203) 382-5551
TWX: 710-465-7079

FLORIDA
P.O. Box 24210
2805 W. Oakland Park Blvd.
Ft. Lauderdale 33307
Tel: (305) 731-7000
TWX: 510-555-4099

P.O. Box 13910
6177 Lake Filmore Dr.
Orlando 32609
Tel: (305) 859-2500
TWX: 810-850-0111

GEORGIA
P.O. Box 28234
430 Interstate North
Atlanta 30328
Tel: (404) 436-6181
TWX: 810-766-4890

HAWAII
2875 So. King Street
Hawaii 96813
Tel: (808) 555-4455

ILLINOIS
5500 Howard Street
Skokie 60076
Tel: (312) 677-0400
TWX: 910-273-3631

INDIANA
3839 Meadow Drive
Indianapolis 46205
Tel: (317) 246-4891
TWX: 810-361-3261

LOUISIANA
P.O. Box 830
3239 Williams Blvd.
Kenner 70062
Tel: (504) 721-6701
TWX: 810-955-5574

MARYLAND
6707 Whitehouse Road
Baltimore 21207
Tel: (301) 944-5400
TWX: 710-862-9157

20010 Century Blvd.
Germantown 20767
Tel: (301) 428-0700

P.O. Box 1548
2 Choke Cherry Road
Rockville 20850
Tel: (301) 948-6370
TWX: 710-828-9084

MASSACHUSETTS
30 Bartlett Ave.
Lexington 02173
Tel: (617) 661-8960
TWX: 710-376-6905

MICHIGAN
2385 Reserch Drive
Farmington 48024
Tel: (313) 676-6400
TWX: 810-252-2900

MINNESOTA
2459 University Avenue
St. Paul 55114
Tel: (612) 545-9461
TWX: 910-563-3734

MISSOURI
1131 Colorado Ave.
Kansas City 64137
Tel: (816) 763-8000
TWX: 910-771-2087

128 Weston Parkway
Maryland Heights 63043
Tel: (314) 567-1455
TWX: 910-764-0830

NEVADA
Las Vegas
Tel: (702) 382-5777

NEW JERSEY
1050 N. Kings Highway
Cherry Hill 08034
Tel: (609) 667-6000
TWX: 710-892-4905

W. 320 Century Rd.
Paramus 07652
Tel: (201) 265-9000
TWX: 710-990-4351

NEW MEXICO
P.O. Box 5185
Station C
6501 Lomas Boulevard N.E.
Albuquerque 87108
Tel: (505) 265-3733
TWX: 910-985-1655

156 Wyatt Drive
Las Cruces 88001
Tel: (505) 522-2485
TWX: 910-983-0550

NEW YORK
6 Automation Lane
CompuNet Park
Albany 12205
Tel: (518) 458-1550
TWX: 210-441-8270

12110 Campville Road
Endicott 13760
Tel: (607) 754-0050
TWX: 510-257-0890

New York City
Manhattan, Bronx
Contact Paramus, N.J. Office

Tel: (609) 265-5000
Brooklyn, Queens, Richmond
Contact Woodbury, NY Office
Tel: (516) 921-0300

62 Washington Street
Poughkeepsie 12501
Tel: (914) 454-7330
TWX: 510-218-0012

39 Saginaw Drive
Rochester 14623
Tel: (716) 473-9500
TWX: 610-263-5981

3858 East Malley Road
Syracuse 13211
Tel: (315) 454-2486
TWX: 710-511-0482

1 Crossways Park West
Woodbury 11797
Tel: (516) 921-0300
TWX: 510-221-2158

NORTH CAROLINA
P.O. Box 5185
Station C
6501 Lomas Boulevard N.E.
Albuquerque 87108
Tel: (505) 265-3733
TWX: 910-985-1655

25575 Center Ridge Road
Cleveland 44145
Tel: (216) 835-0500
TWX: 810-477-9129

330 Progress Rd.
Dayton 45449
Tel: (513) 858-8202
TWX: 810-459-1925

6665 Busch Blvd.
Columbus 32229
Tel: (614) 848-1300

OKLAHOMA
Oklahoma City 73132
Tel: (405) 771-0200
TWX: 910-906-6462

OREGON
17850 SW Bonnes Ferry Road
Tualatin 97052
Tel: (503) 620-3350
TWX: 910-767-8714

PENNSYLVANIA
2500 Moss Side Boulevard
Monroeville 15146
Tel: (412) 272-0724
TWX: 710-797-3550

1021 8th Avenue
King of Prussia Industrial Park
King of Prussia 19406
Tel: (215) 265-7000
TWX: 510-680-2370

RHODE ISLAND
113 Westminster Ave.
East Providence 02911
Tel: (401) 434-5535
TWX: 710-381-7373

TENNESSEE
Memphis
Tel: (901) 274-7477

TEXAS
P.O. Box 1270
201 E. Arapaho Rd.
Richardson 75080
Tel: (214) 231-6101
TWX: 910-867-4225

P.O. Box 27409
6300 Westpark Drive
Suite 300
Houston 77027
Tel: (713) 781-8000
TWX: 910-881-2645

231 Billy Mitchell Road
San Antonio 78226
Tel: (512) 434-4221
TWX: 910-871-1170

UTAH
2850 South Main Street
Salt Lake City 84115
Tel: (801) 487-0715
TWX: 910-925-5581

VIRGINIA
P.O. Box 6514
2111 Spencer Road
Richmond 23230
Tel: (804) 285-9431
TWX: 710-956-0157

WASHINGTON
Bellevue Office Bldg.
1223 114th St.
Bellevue 98004
Tel: (206) 454-3971
TWX: 910-443-2103

WEST VIRGINIA
Charleston
Tel: (304) 245-1640

WISCONSIN
9431 W. Beloit Road
Sufts 117
Milwaukee 53227
Tel: (414) 441-0550

FOR U.S. AREAS NOT LISTED:
Contact the regional office nearest you: Atlanta, Georgia; ...
North Hollywood, California; ...
Paramus, New Jersey; ...
Skokie, Illinois. Their complete addresses are listed above.

Servico Only

CANADA

ALBERTA
Hewlett-Packard (Canada) Ltd.
1748 Kingsway Ave.
Edmonton T5C 0K5
Tel: (403) 452-3870
TWX: 610-651-7431

Hewlett-Packard (Canada) Ltd.
825 - 8th Ave., S.W.
Suite 804
Calgary
Tel: (403) 264-4279

BRITISH COLUMBIA
Hewlett-Packard (Canada) Ltd.
837 E. Cordova St.
Vancouver 6
Tel: (604) 254-0533

MANITOBA
Hewlett-Packard (Canada) Ltd.
513 Century St.
Winnipeg
Tel: (204) 786-7581
TWX: 610-571-3531

NOVA SCOTIA
Hewlett-Packard (Canada) Ltd.
274 Burtin Village St.
Suite 210
Halifax
Tel: (902) 455-0382
TWX: 610-271-6882

ONTARIO
Hewlett-Packard (Canada) Ltd.
1785 Woodbine Dr.
Ottawa K2C 0P0
Tel: (613) 235-6180, 255-6530
TWX: 610-502-8908

Hewlett-Packard (Canada) Ltd.
50 Galaxy Blvd.
Rexdale
Tel: (416) 677-9531
TWX: 610-492-4246

QUEBEC
Hewlett-Packard (Canada) Ltd.
275 Humes Boulevard
Pointe Claire H9R 1G7
Tel: (514) 597-4232
TWX: 810-420-3022
Telex: 33 20807

Hewlett-Packard (Canada) Ltd.
2376 Galvani Street
Steyf GIN 4G4
Tel: (418) 688-8710

FOR CANADIAN AREAS NOT LISTED:
Contact: Hewlett-Packard (Canada) Ltd. in Pointe Claire.

CENTRAL AND SOUTH AMERICA

ARGENTINA
Hewlett-Packard Argentina
S.A.C. S.R.L.
Luzalle 1171 3
Buenos Aires
Tel: 35-0436, 35-0617, 35-0341
Telex: 012-1303
Cable: HEWPACK ARG

BOLIVIA
Stambak & Max (Bolivia) LTDA
Av. Mariscal Santa Cruz 1342
La Paz
Tel: 40676, 53163, 52421
Telex: 3500214
Cable: BURMAR

BRAZIL
Hewlett-Packard Do Brasil
L.E.C. Ltda.
Rua Frei Caneca 1119
01307-Sao Paulo-SP
Tel: 268-1111, 267-5858
Telex: 309151/2-3
Cable: HEWPACK Sao Paulo

Hewlett-Packard Do Brasil
L.E.C. Ltda.
Praça Dom Feliciano, 78
90000-Porto Alegre-RS
Rio Grande do Sul (RS) Brasil
Tel: 25-8470
Cable: HEWPACK Porto Alegre

Hewlett-Packard Do Brasil
L.E.C. Ltda.
Rua da Matriz 29
20000-Rio de Janeiro-GB
Tel: 266-2632
Telex: 230075 HEWPACK
Cable: HEWPACK Rio de Janeiro

CHILE
Hercz Catagn y Cia. Ltda.
Casilla 15-475
Santiago
Tel: 423 86
Cable: DALCAONI Santiago

COLOMBIA
Instrumentación
Hensik A. Langobæk & Rier S.A.
Carrera 7 No. 48-29
Apartado Aéreo 6287
Bogotá, D.E.
Tel: 45-78-06, 45-55-46
Cable: AARIS Bogota
Telex: 44400/INSTRIO

COSTA RICA
Lic. Alfredo Callegos Guisán
Apartado 10159
San José
Tel: 21-06-13
Cable: GALGUR San José

ECUADOR
Laboratorios de Radio-Ingeniería
Calle Guayaquil 1246
Post Office Box 3199
Quito
Tel: 212-496; 219-185
Cable: HOFVATH Quito

EL SALVADOR
Electronic Associates
Apartado Postal 1682
Centro Comercial Gigante
San Salvador, E. Salvador C.A.
Pasaje Escalón 0649-4* Fisco
Tel: 23-44-80, 23-21-37
Cable: ELECCAS

GUATEMALA
IPESA
Avenida La Reforma 3-48,
Zona 9
Guatemala
Tel: 33627, 64735
Telex: 5192 TELTRO GU

MEXICO
Hewlett-Packard Mexico S.A. de C.V.
Torres Adalberto No. 21 11 Piso
Col. del Valle
México 12, D.F.
Tel: 543-42-39
Telex: 017-74-517

NICARAGUA
Roberto Tejada G.
Apartado Postal 659
Edificio Terrán
Managua
Tel: 3451, 3452
Cable: HOFERAN Managua

PANAMA
Electrónico Ralboa, S.A.
P.O. Box 4929
Ave. Manuel Espinosa No. 13-50
Baja Zona
Panama City
Tel: 230833
Telex: 3281133, Curunda.
Cable: ELECTRON Panama City

PARAGUAY
Z. I. Melamed S.R.L.
Division: Aparatos y Equipos
Medicos
Division: Aparatos y Equipos
Scientificos y de
Investigacion
P.O. Box 676
Chile, 487, Edificio Victoria
Asunción
Tel: 4-5069, 4-6772
Cable: HEMIL

PERU
Compañía Electro Médica S.A.
Ave. Enrique Canayal 312
San Isidro
Cas. Ita 1036
Lima
Tel: 22-3900
Cable: ELMED Lima

PUERTO RICO
San Juan Electronics, Inc.
P.O. Box 5137
Ponce de Leon 154
Poa. 3-PTA de Tierra
San Juan 00906
Tel: (809) 725-3342, 722-3342
Cable: SATRONICS San Juan
Telex: SATRON 3450 132

URUGUAY
Fablo Ferrando S.A.
Comercial e Industrial
Avenida Italia 2877
Casilla de Correo 370
Montevideo
Tel: 40-3102
Cable: RADILUM Montevideo

VENEZUELA
Hewlett-Packard de Venezuela
C.A.
Apartado 50933
Edificio Segre
Tercero Transversal
Los Rucos Norte
Caracas 107
Tel: 35-00-11
Telex: 21146 HEWPACK
Cable: HEWPACK Caracas

FOR AREAS NOT LISTED:
CONTACT:
Hewlett-Packard
Inter-Americas
3200 Hillview Ave.
Palo Alto, California 94304
Tel: (415) 493-1501
TWX: 910-323-1267
Cable: HEWPACK Palo Alto
Telex: 034-8300, 034-8493

E 11/73

EUROPE

AUSTRIA
Hewlett-Packard GmbH
Händlstrasse 52, 3
P.O. Box 7
A-1205 Vienna
Tel: 0222 33 66 05 to 09
Cable: HEWPACK Vienna
Telex: 75923 hwpak a

BELGIUM
Hewlett-Packard Benelux
S.A. N.V.
Avenue de Col-Vert, 1
Groenkrugglaan
B-1170 Brussels
Tel: 021 72 22 44
Cable: PALOBN Brussels
Telex: 23 484 palobn bru

DENMARK
Hewlett-Packard A/S
Datovej, 35
DK-3450 Birkerød
Tel: 01: 81 56 40
Cable: HEWPACK AS
Telex: 165 40 hp ds

Hewlett-Packard A/S
Torvet 9
DK-8500 Silkeborg
Tel: 06: 82 73 56
Telex: 165 40 hp ds
Cable: HEWPACK AS

FINLAND
Hewlett-Packard Oy
Bulevardi 26
P.O. Box 22185
SF-00120 Helsinki 12
Tel: (01) 13230
Cable: HEWPACKOY Helsinki
Telex: 12 15863 hel

FRANCE
Hewlett-Packard France
Quartier de Courtabouff
Boite Postale No. 6
F-91401 Orsay
Tel: 01 90 78 25
Cable: HEWPACFR Orsay
Telex: 60048

Hewlett-Packard France
Agence Régionale
4 Quai des Etruits
F-69321 Lyon Cedex 1
Tel: 078 42 63 45
Cable: HEWPAC Lyon
Telex: 31617

Hewlett-Packard GmbH
Zone Aéronautique
Quartier de Clément Ader
F-31170 Colomiers
Tel: 061 86 81 55
Telex: 51957

Hewlett-Packard France
Agence Régionale
Boulevard Fenuo-Gamaru
Boite Postale No. 11
F-71300 Lagny
Tel: 47 24 60 55
Telex: 43720

Hewlett-Packard France
Agence Régionale
53 Avenue de Rochester
F-35000 Rennes
Tel: 49 36 38 21
Telex: 74912 F

Hewlett-Packard France
Agence Régionale
24, Allée de la Robertesse
F-72000 Strasbourg
Tel: 84 35 43 20 21
Telex: 89141
Cable: HEWPACFR STG

GERMAN FEDERAL REPUBLIC
Hewlett-Packard GmbH
Vertriebszentrale Frankfurt
Bergerstrasse 117
Postfach 560 140
D-6000 Frankfurt 56
Tel: (0611) 50 04-1
Cable: HEWPACSA Frankfurt
Telex: 81 32 49 FA

Hewlett-Packard GmbH
Vertriebsbüro Böblingen
Heerenbergstrasse 113
D-7030 Böblingen, Württemberg
Tel: (07031) 66 72 87
Cable: HE44 Böblingen
Telex: 72 65 738 Dn

Hewlett-Packard GmbH
Vertriebsbüro Düsseldorf
Voigtsanger Weg, 38
D-4000 Düsseldorf
Tel: (0211) 65 80 31-38
Telex: 25 95 533 hppd d

Hewlett-Packard GmbH
Vertriebsbüro Hamburg
Wandstraße 23
D-2000 Hamburg 1
Tel: 040 24 13 93
Cable: HEWPACSA Hamburg
Telex: 21 63 032 hppd d

Hewlett-Packard GmbH
Vertriebsbüro Hannover
Mellendorfer Strasse 3
D-3000 Hannover-Kirchfeld
Tel: 0511 50 06 26
Telex: 823 960

Hewlett-Packard GmbH
Vertriebsbüro Nürnberg
Herbucenstrasse 42
D-9000 Nürnberg
Tel: 091 57 10 66
Telex: 823 960

Hewlett-Packard GmbH
Vertriebsbüro München
Unterhachinger Strasse 26
TSAR Center
D-8012 Unterhaching
Tel: 089 861 20 61 /
Telex: 52 49 81
Cable: HEWPACSA München

WEST Berlin
Hewlett-Packard GmbH
Vertriebsbüro Berlin
Wilmerdoffer Strasse 113-114
D-1000 Berlin W 12
Tel: (030) 317460
Telex: 18 34 65 hppind

GREECE
Kostas Patsianos
18, Ermau Street
GR-Athens 126
Tel: 3235-303, 3233-305
Cable: SAKAP Athens
Telex: 21 59 62 Ikar gr

IRELAND
Hewlett-Packard Ltd.
224 Bath Road
GS Slough, SL1 4 DS, Bucks
Tel: Slough 07531 32341
Cable: HEWPAC Slough
Telex: 848413

Hewlett-Packard Ltd
The Griffons
Stamford New Road
Atrincham, Chester
Tel: (061) 928-9021
Telex: 680068

ITALY
Hewlett-Packard Italiana S.p.A.
Via America Vesputo 7
F-20124 Milan
Tel: 2 6751 10 lines
Cable: HEWPACKIT Milan
Telex: 33048

Hewlett-Packard Italiana S.p.A.
Piazza Marconi, 25
I-00145 Rome - Eur
Tel: 61 591254-5, 591267
Cable: HEWPACKIT Rome
Telex: 61514

Hewlett-Packard Italiana S.p.A.
Vicolo Pastori, 3
I-35100 Padova
Tel: 49 55 40 62
Telex: 32046 via Milan

Hewlett-Packard Italiana S.p.A.
Via Dotti, 24
I-30129 Turin
Tel: 11 53 82 64
Telex: 32046 via Milan

LUXEMBURG
Hewlett-Packard Benelux
S.A. N.V.
Avenue de Col-Vert, 1
Groenkrugglaan
B-1170 Brussels
Tel: 021 72 22 44
Cable: PALOBN Brussels
Telex: 23 484

NETHERLANDS
Hewlett-Packard Benelux N.V.
Weerdestein 117
P.O. Box 7823
NL-Amsterdam, 1011
Tel: 020-42 77 44, 42 29 66
Cable: PALOBN Amsterdam
Telex: 13 216 hppal

NORWAY
Hewlett-Packard Norge A.S.
Kryvheim 13
P.O. Box 169
N-1341 Mastum
Tel: 002: 53 83 60
Telex: 16821 noras n

PORTUGAL
Teletra Empresa Técnica de
Equipamentos Eléctricos S.A. S.
Rua Rodrigo da Fonseca 103
P.O. Box 2531
F.Lisboa 1
Tel: 181 68 53 72
Cable: TELETRA Lisbon
Telex: 1598

SPAIN
Hewlett-Packard España, S.A.
E.Madrid 16
Tel: 494 26 00
Telex: 23515 hpe

Hewlett-Packard España, S.A.
Milanesa 21-23
E.Barcelona 17
Tel: 17 203 52 00
Telex: 52003 hpe e

SWEDEN
Hewlett-Packard Sverige AB
Enighetsågen 1-3
Fack
S-161 20 Bromma 20
Tel: 08 98 12 50
Cable: MEASUREMENTS
Stockholm
Telex: 13121

Hewlett-Packard Sverige AB
Hagakerstegen 9C
S-431 41 Mölndal
Tel: 031 27 68 30 31
Telex: Via Brønna

SWITZERLAND
Hewlett-Packard (Schweiz) AG
Zürcherstrasse 20
P.O. Box 64
CH-8052 Schlieren Zurich
Tel: 011 98 16 21 24
Cable: HPAC CH
Telex: 53933 hpaq ch

Hewlett-Packard (Schweiz) AG
9, Chemin Louis-Pictet
CH-1214 Vernier - Geneva
Tel: 0221 41 4950
Cable: HEWPACSA Geneva
Telex: 27 333 hpsa ch

TURKEY
Telekom Engineering Bureau
Sakip Sok. No. 15-1
Anadoluhisari
P.O. Box 437 Beyoğlu
TR-Istanbul
Tel: 49 40 40
Cable: TELEKOM Istanbul
Telex: 680068

UNITED KINGDOM
Hewlett-Packard Ltd.
224 Bath Road
GS Slough, SL1 4 DS, Bucks
Tel: Slough 07531 32341
Cable: HEWPAC Slough
Telex: 848413

Hewlett-Packard Ltd.
The Griffons
Stamford New Road
GS Atrincham, Chester
Tel: (061) 928-9021
Telex: 680068

Hewlett-Packard Ltd's registered
address for V.A.T. purposes
only.
7C, Finsbury Pavement
London, EC2A1JX
Registered No: 895997

SPECIALIST COUNTRIES
PLAZA CONTACT:
Hewlett-Packard Ges.m.b.H.
Händlstrasse 52/3
A-1205 Vienna
Tel: 0222 33 66 05 to 09
Cable: HEWPACK vienna
Telex: 75923 hwpak a

ALL OTHER EUROPEAN COUNTRIES CONTACT:
Hewlett-Packard S.A.
Avenue de Courtabouff
P.O. Box 6
F-91401 Orsay
Tel: 01 90 78 25
Cable: HEWPAC4SA Geneva
Telex: 23 484

AFRICA, ASIA, AUSTRALIA

ANGOLA
Teletra Empresa Técnica de
Equipamentos Eléctricos
(SAR)
Rua de Barbosa, Rodrigues
42-1 01
P.O. Box 6687
Lunda
Cable: TELETRA Lunda

AUSTRALIA
Hewlett-Packard Australia
Pty. Ltd.
32-38 Weir Street
Slee Hill, 3146
Victoria
Tel: 20 1373 (6 lines)
Cable: HEWPARD Melbourne
Telex: 31 524

Hewlett-Packard Australia
Pty. Ltd.
31 Bridge Street
Pymble,
New South Wales, 2073
Tel: 449 5565
Telex: 21561
Cable: HEWPARD Sydney

Hewlett-Packard Australia
Pty. Ltd.
37 Churchill Road
Prospect 5042
South Australia
Tel: 44 8151
Cable: HEWPARD Adelaide

Hewlett-Packard Australia
Pty. Ltd.
Casablanca Buildings
196 Adelaide Terrace
Perth, W.A. 6009
Tel: 254803
Cable: HEWPARD Perth

Hewlett-Packard Australia
Pty. Ltd.
10 Woolley Street
P.O. Box 191
Dickson A.C.T. 2902
Tel: 49 8194
Cable: HEWPARD Canberra ACT

Hewlett-Packard Australia
Pty. Ltd.
2nd Floor, 49 Gregory Terrace
Brisbane, Queensland, 4000
Tel: 29 1544

Ceylon
Jelites Electricals Ltd.
P.O. Box 681
60, Park St.
Colombo 2
Tel: 26596
Cable: HOTPOINT Colombo

CYPRUS
Kypricos
19 Gregorius & Xenodoulos Road
P.O. Box 1132
CY Nicosia
Tel: 4528/29
Cable: KYPRONICS PANDEHS

ETHIOPIA
African Salespower & Agency
Private Ltd., Co
P.O. Box 718
Bambay 400 020
Addis Ababa
Tel: 17285
Cable: ASKO Addisababa

HONG KONG
Schmidt & Co. (Hong Kong) Ltd.
P.O. Box 297
Comaught Centre
397, Floor
Comaught Road, Central
Hong Kong
Tel: 240188, 252735
Cable: HXK766
Cable: SCHMIDCO Hong Kong

INDIA
Blue Star Ltd.
Kasturji B. Ildines
Jambhedi Taji Rd.
Bombay 400 020
Tel: 29 56 21
Telex: 3751
Cable: BLUESTAR

Blue Star Ltd.
Cahana
414 2 Vih Savarua Marg
Pranodvee
Bombay 400 025
Tel: 45 78 87
Telex: 4093
Cable: FROSTBLUE

Blue Star Ltd.
Boré Box House
Pranodvee
Bombay 400 025
Tel: 45 73 03
Telex: 3751
Cable: BLUESTAR

Blue Star Ltd.
14 40 Chiu Lines
Kampur 208 001
Tel: 6 88 82
Cable: HUBESTAR

Blue Star Ltd.
7 Hare Street
P.O. Box 506
Calcutta 700 001
Tel: 23 03 31
Telex: 655
Cable: BLUESTAR

Blue Star Ltd.
Blue Star House
34 Ring Road
Lagat Vajir
New Delhi 110 024
Tel: 62 37 76
Telex: 2463
Cable: BLUESTAR

Blue Star Ltd.
Blue Star House
11-11A Magrath Road
Bangalore 560 025
Tel: 55668
Telex: 430
Cable: BLUESTAR

Blue Star Ltd.
1-1-117 J
21 South Devi Road
Secunderabad 500 003
Tel: 7 63 91, 7 29 93
Cable: BLUEFRST
Telex: 459

Blue Star Ltd.
23 24 Second Line Beach
Madras 600 001
Tel: 23954
Telex: 379
Cable: BLUESTAR

Blue Star Ltd.
Nataraj Mansions
2nd Floor Bistupur
Jammehpur 831 001
Tel: 18 63
Cable: BLUESTAR
Telex: 240

INDONESIA
Bah Solon Trading Coy. N.V.
D-31181 Merdeka 29
Bandung
Tel: 4315, 31503
Cable: ILMU
Telex: 65-809

IRAN
Multi Corp International Ltd.
Avenue Saryan 130
P.O. Box 1212
16, Téhéran
Tel: 83 10 35-39
Cable: MULTICORP Téhéran
Telex: 2653 MCI IR

ISRAEL
Electronics & Engineering
4 Div. of Motorola Israel, 10
17 Amnady Street
Tel-Aviv
Tel: 35943 (3 lines)
Cable: ESISTE, Tel-Aviv
Telex: 33559

JAPAN
Yokogawa Hewlett-Packard Ltd
Dabshi Building
1-5-1 Toyogi
Shibuya-ku, Tokyo
Tel: 03-370-2281/52
Telex: 232-2021HP
Cable: HPYOKAWET TOK 23 721

Yokogawa-Hewlett-Packard Ltd.
N.ve. Ibaraki Bldg.
2-2-8 Kaizuka
Ibaraki-Shi
Osaka
Tel: 0726, 23 1541
Telex: 5332-345 YHP OSAKA

Yokogawa-Hewlett-Packard Ltd.
Nakamo Building
No. 24 Kamishirayama cho
Nakamura-ku, Nagoya City
Tel: (052) 571-5171
Yokogawa Hewlett-Packard Ltd
Nitto Rise
2-4-2 Shinoharukita
Yokohama
Tel: 045-432-1504
Telex: 382-3204 YHP YOK

Yokogawa-Hewlett-Packard Ltd
Cruz Bldg.
4m. 603 3,
2-Dilom
7201 OHO
Mito, 310
Tel: 0292-21-5000

KENYA
Kenya Electronics
P.O. Box 1103
Nairobi, Kenya
Tel: 57726
Cable: PROTON

KOREA
American Trading Company
Korea
P.O. Box 1103
Daejeon Bldg., 8th Floor
107 Seong-ro
Inchong-ro, Seoul
Tel: (4 lines) 72-8924-7
Cable: AMTRACO Seoul

LEBANON
Constantin E. Macridis
P.O. Box 213
Ri-Berret
Tel: 22086
Cable: ELECTRONIC, EAR Beirut

MALAYSIA
MECOMB Malaysia Ltd.
2 Lorong 13 SA
Section 13
Petaling Jaya, Setangar
Cable: MECOMB Kuala Lumpur

MOZAMBIQUE
A.S. Gondres, Lda.
162, Av. D. Luis
P.O. Box 107
Lourenço Marques
Tel: 27091, 27114
Telex: 6-703 Négon Mo
Cable: NEGON

NEW ZEALAND
Hewlett-Packard (N.Z.) Ltd
94-95 Dixon Street
P.O. Box 9443
Courtenay Place
Wellington
Tel: 69-989
Telex: 3898
Cable: HEWPACK Wellington

Hewlett-Packard (N.Z.) Ltd
Fakuranga Professional Centre
267 Fakuranga Highway
Box 91099
Papakura
Tel: 369-651
Cable: HEWPACK Auckland

NIGERIA
The Electronics Instrumentation
Firms Ltd. (TEIL)
144 Agege Motor Rd., Mushin
P.O. Box 6645
Lagos
Cable: THETEL Lagos

The Electronics Instrumentation
Firms Ltd. (TEIL)
16th Floor Cocoa House
201 B, 5102
Ibadan
Tel: 22325
Cable: THETEL Ibadan

PAKISTAN
Mushko & Company, Ltd.
Osman Chambers
Abdullah Khan Road
Karachi 2
Tel: 51207, 512927
Cable: COOPERATOR Karachi

Mushko & Company, Ltd.
18B, Satellite Town
Rawalpindi
Tel: 41924
Cable: FEMUS Rawalpindi

PHILIPPINES
Electronics, Inc.
6th Floor, Amangdama
Development Corp. Bldg.
Ayala Avenue, Makati, Rizal
C.P.O. Box 1028
Manila, Rizal
Tel: 86-18-87, 87-76-77,
87-86-88, 87-18-35, 88-91-71,
43-81-12, 83-82-12
Cable: FITTEL Manila

SINGAPORE
Mechanical & Combustion
Engineering Company Pte.,
Ltd.
10 12, Jalan Katong
Red Hill Industrial Estate
Singapore, 1
Tel: 67131 (7 lines)
Cable: MECOMB Singapore

Hewlett-Packard (Far East)
Area Office
P.O. Box 87
Alexandria Post Office
Singapore 3
Tel: 633022
Cable: HEWPACK SINGAPORE

SOUTH AFRICA
Hewlett-Packard (South Africa)
Pty. Ltd.
Tel: 3898
Cable: HEWPACK House
Daphne Street, Wynyard,
Sandton, Transvaal 2001
Tel: 407641 (five lines)

Hewlett-Packard South Africa
Pty., Ltd.
Greenacre House
Bree Street
Cape Town
Tel: 2-6941, 2-3
Cable: HEWPACK Cape Town
Tel: 0006 31

Hewlett-Packard South Africa
Pty., Ltd.
6-11 Ridge Road, Durban
P.O. Box 95
Overport Natal
Tel: 88-0102
Telex: 56795
Cable: HEWPACK

TAIWAN
Hewlett-Packard Taiwan
39 Chung Shan West Road
Sec. 1
Yuehsan Insurance
Corp. Bldg. 7th Floor
Taipei
Tel: 381360, 112, 375121,
Ext. 250-249
Telex: 1P824 HEWPACK
Cable: HEWPACK Taipei

THAILAND
UNIMESA Co., Ltd.
Chongkietee Bldg.
56 Surawongse Road
Bangkok
Tel: 37956, 31300, 31307,
37540
Cable: UNIMESA Bangkok

UGANDA
Uganda Tele Electric Co., Ltd.
P.O. Box 4448
Kampala
Tel: 57279
Cable: COMUL Kampala

VIETNAM
Phimular Trading Int.
P.O. Box H-3
215 Hien-Vuong
Saigon
Tel: 20-805, 93308
Cable: PHINTRA SA GON 242

ZAMBIA
R.F. Tibury (Zambia) Ltd
P.O. Box 2792
Lusaka
Zambia, Central Africa
Tel: 72323
Cable: ARJAVIEE Lusaka

MEDITERRANEAN AND MIDDLE EAST COUNTRIES NOT SHOWN PLEASE CONTACT:
Hewlett-Packard
Co-ordination Office for
Mediterranean and Middle
East Operations
Via Marconi 25
I-00144 Rome-Ly, Italy
Tel: 61 59 40 29
Cable: HEWPACKIT Rome
Telex: 61514

OTHER AREAS NOT LISTED, CONTACT:
Hewlett-Packard
Export Trace Company
3200 Hillview Ave.
P.O. Box 10, California 94301
Tel: 415 326-7000
(In 71 493-1501)

Telex: 9 975 1757
Cable: HEWPACK Ralic. A to
Telex: 034-0300, 034-8493

hp MANUAL CHANGES

MODEL 3490A

MULTIMETER

Manual Part No. 03490-90016

■ New or Revised Item

ERRATA

Title Page (at beginning of manual). Change to read: "The main body of this manual applies to instruments with serial numbers 1637A04596 and greater Δ ..."

Page 6-3, Table 6-1.

Delete:

A1MP1	1200-0469	Socket IC
A1MP2	1200-0469	Socket IC
A1MP3	1200-0431	Socket IC

Page 7-43/7-44, Figure 7-22.

Change:
R322 from 30 K to 200 K

Page 8-10 (Change No. 18). Change to read:

"... (for serial numbers 1529A04595 and lower)".

Change A1C302 to 0180-0734, 10 μ F

Add A1R303, 0811-9020, 1200 ohm

Delete A1R322, R323, R324, R325

CHANGE NO. 1 applies to serial numbers 1637A04736 and greater.

Page 6-2, Table 6-1.

Add:
C123-128, Cap-Fxd, .1 μ F, 100 V, 0160-3622

Change:
Figure 7-26 as illustrated

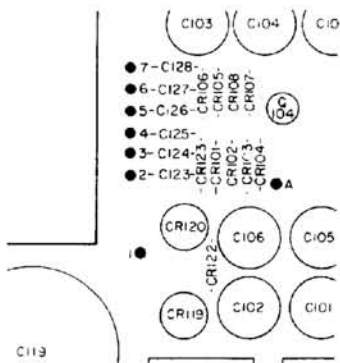
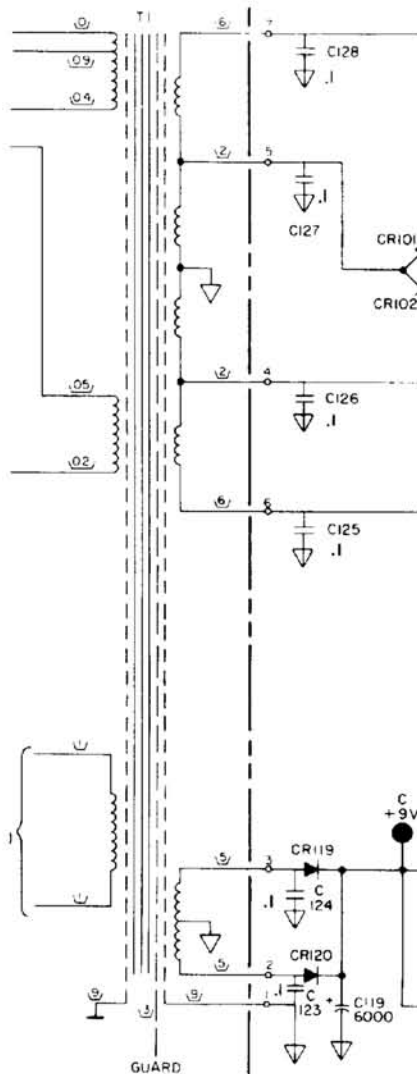

Figure 7-26. Component Locator.

Figure 7-26. Schematic Diagram.



Page 7-43/7-44, Figure 7-22. Change U303(4) from -17 V to ground.

CHANGE NO. 2 applies to serial numbers 1637A04806 and greater

Page 6-2, Table 6-1.

Change From:
C12, Cap-Fxd, 240 pF 300 V, 0140-0199
C109, Cap-Fxd, 400 pF, 1000 V, 0150-0071

To:
C12, Cap-Fxd, 110 pF, 300 V, 0140-0194
C109, Cap-Fxd, Pad Value, 0150-999P
82 pF, 300 V, 0140-0193
220 pF, 500 V, 0140-0083
240 pF, 300 V, 0140-0199

CHANGE NO. 3 applies to serial numbers 1637A05366 and greater.

Page 6-2, Table 6-1. Change A1C112, C117 from -hp- Part Number 0150-0096 to 0150-0084, Qty. 6, Description C:FXD CER .1 UF +80 -20% 100 VDCW, Mfr. Code: 72982, Mfr. Part Number 8131-100-651-104Z.

Page 7-51/7-52, Figure 7-26. Change values of A1C112, C117 on schematic from .05 UF to .1 UF.

CHANGE NO. 4 applies to all serial numbers.

Page 1-2, Paragraph 1-13. Change the part number of the HP-IB Service Kit (3490A) from 44090A to 03490-69800.

Page 1-5, Table 1-2. Under Power Requirements: Change to read as follows:

100 V, 120 V, 220 V, or 240 V(± 5%, - 10%); 48 Hz to 440 Hz

Page 6-6, Table 6-1. Delete A1R207 -hp- Part Number 0698-4510, Qty 3.
Change A1R214 to Qty 2.

Page 6-9 Table 6-1. Add -hp- Part Number 0350-0902, Qty 2
Description: Washer Flat, Mfr. Code: 28480, Mfr Part Number 0350-0902.

Page 6-28, Table 6-1. Change -hp- Part Number 44090A to 03490-69800 HP-IB Service Kit for 3490A.
Change S1 from -hp- Part Number 3101-1720 to 3101-2216.

Page 6-29, Table 6-1. Change -hp- Part Number from 44090-90001 to P-03490-69800-1, Description: Part Note.
Change -hp- Part Number from 44090-64501 to 03490-64501, Description: Carrying Case Assy.
Add -hp- Part Number 0340-0170, Qty 2, Description: Insulator, Bshg, Mfr. Code: 28480, Mfr. Part Number 0340-0170.

CHANGE NO. 5 applies to serial numbers 1637A05226 and greater.

Page 6-27, Table 6-1. Change C1, C2 from -hp- Part No. 0160-3333 to 0160-4281, Qty 2, Description: C:FXD CER 2200 PF ±20% 250 WVAC, Mfr. Code: 28480, Mfr. Part Number 0160-4281.
Add C3 -hp- Part Number 0160-4259, Qty 1, Description: C:FXD CER .22 UF ± 10% 250 VAC (RMS) Mfr. Code: 05917, Mfr. Part Number PME271M622.

Page 7-51/7-52, Figure 7-26. Change value of C1, C2 from .005 UF to .0022 UF.
Change Figure 7-26 by adding C3 and R2 as shown.

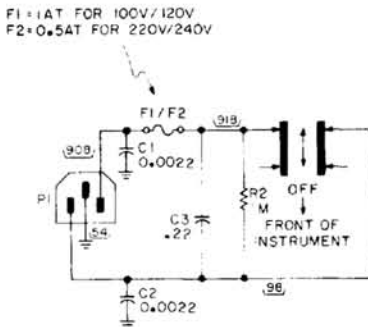

P/O Figure 7-26.

CHANGE NO. 6 applies to serial numbers 1637A05086 and greater.

Page 6-2, Table 6-1. Add A1C14* -hp- part number 0140-0280, Description: C:FXD 680 PF ± 5% VDC (MICA), Qty 1, Mfr. Code: 04522, Mfr. Part Number DM15F681J0300WV1CR.

Add the following padding list for A1C14*:

560 PF	0140-0178
750 PF	0160-2035
820 PF	0160-2009

Page 6-4, Table 6-1. Change from: A1Q206, Q207, 1855-0308, JFET-DUAL DN324, Qty 2
To: A1Q206, Q207, 1855-0311, JFET-DUAL DN196, Qty 2

Page 6-8, Table 6-1. Change from:

A1U4, U6, U11			
U14, U20, U22	1820-0077	IC-SN747N	Qty 7
A1U5, U12	1820-0099	IC-SN7493N	Qty 2
A1U7	1820-0788	TLL FF74174N	Qty 1
A1U10	1820-0174	IC-SN7404N	Qty 1
A1U13, U18	1820-0591	TTL INV 74L 54N	Qty 2
A1U15, U19, U24	1820-0622	TTL MPLX 74151N	Qty 3
A1U21	1820-0233	IC-SN74193N	Qty 1
A1U23	1820-0586	IC-DGTL DM74L04N	Qty 1

To:

A1U4, U6, U11			
U14, U20, U22	1820-1112	TTL-DUALFF74LS74N	Qty 7
A1U5, U12	1820-1478	TTL CNTR 74LS93N	Qty 2
A1U7	1820-1196	IC-SN74LS174N	Qty 1
A1U10, U23	1820-1199	TTL INV 74LS04N	Qty 2
A1U13, U18	1820-1285	IC/SN74LS554	Qty 2
A1U15, U19, U24	1820-1217	IC SN74LS151	Qty 3
A1U21	1820-1194	IC-SN74LS193N	Qty 1

Page 6-11, Table 6-1. Change A6Q3, Q5, Q6 from -hp- Part Number 1854-0071 to 1854-0404; XSTR-S1 NPN.